

ROCKWOOD



ASSA ABLOY

Architectural Hardware

ASSA ABLOY, the global leader
in door opening solutions

Introduction

Since 1946 Rockwood Manufacturing Company has taken pride in its reputation of producing quality builder's hardware. Our focus is on the manufacture of door trim hardware for the commercial and residential market. Although many items in our product line are industry standard items ready to be shipped from our finished goods inventory, there is a routine need for made-to-order products such as special size kick plates, push bars, corner guards, and protection plates. It is our goal to produce these items with a short lead-time to accommodate your delivery requirements and provide a custom fit look to your door trim hardware. Call Rockwood for all your architectural door trim needs.

BHMA/ANSI Specifications

We have listed ANSI cross-reference numbers throughout our catalog. Because we usually make more than one grade of product, the cross-reference can be relied on for design equivalence reference only. Contact the factory if you require a certificate of conformance.

Weights

Unless otherwise noted, the weight listed in our catalog is the approximate weight for a brass, bronze, or stainless steel based item. Aluminum based items are approximately 1/3 the weight of other materials.

Barrier Free Hardware

Some variations of standard designs may be desirable in areas to enhance accessibility for persons with upper limb impairments. In such areas it is recommended that door pulls have 2 1/2" clearance. Most of our products can be modified to meet this suggested dimension. Please specify the product number prefixed with the letters BF; for example #BF157.

Fastening Systems

The important aspect of a fastening system is that it attaches the pull solidly to the door and does not allow "play" between the pull and the door. Rockwood's mounting systems do this; we guarantee the security of our back to back and thru bolt mounted products for the life of the door.

Custom Manufacturing

Rockwood is devoted to making the door hardware you want. Please don't hesitate to ask for minor design or size changes to existing products or completely custom designs. See our full color Architectural Door Pull Brochure for custom designs and capabilities.

Templates

Commonly used templates are available on our website at www.rockwoodmfg.com.



Our precision measurements ensure quality products.



3 Numeric Index
 7 Architectural Finishes
 8 Finish Tips

A1 - A21 Section A — Push and Pull Bars
 Push and Pull Bar Mounting Details
 Pull Bars
 Push Bars
 Push and Pull Bar Sets
 Series 47 Push and Pull Bar Mounting Details
 Series 47 Solid & Tubular Push Bars
 Series 47 Solid Straight/Offset Push & Pull Bar Sets
 Series 47 Tubular Straight/Offset Push & Pull Bar Sets

B1 - B34 Section B — Push and Pull Plates, Door Pulls
 Flush Pulls
 - Barrier Free
 - Combination
 - Cylinder
 - Dead Lock
 - Security
 Offset Door Pulls Mounting Details
 Offset Door Pulls
 - 45° Offset
 - 90° Offset
 - Heavy Duty Offset
 - Tubular
 Pull Plates
 Push Plate Order Information
 Push Plates
 Straight Door Pulls Mounting Details
 Straight Door Pulls
 - Cast
 - Hospital
 - Push Pull Sets
 - Security
 - Tubular
 - Wooden
 Vandal Resistant Trim

C1 - C26 Section C — Door Plates, Door Edges & Protectors
 Angle Plates
 Corner Guards
 Custom Strikes
 Door Edges (Mortise, Non-Mortise, Overlapping)
 Door Edge Order Forms & Worksheets
 Door Plates
 - Clear Plastic
 - Metal
 - Laminate
 - Plastic
 - Shaped
 Latch Guard Covers
 Latch Protectors
 Trim Protector Bars
 - Exit Device
 - Heavy Duty
 - Lever Handle
 - Standard Duty
 Vertical Rod Covers

D1 - D24 Section D — Stops
 Dome Stops
 Door Stops
 - Automatic
 - Heavy Duty
 - Hinge Pin
 - Kick Down
 - Spring
 Door Stop Risers
 Overhead Holders and Stops
 Roller Stops
 Wall Stops

E1 - E20 Section E — Bolts and Latches
 Door Coordinators
 - 1600 Series
 - Carry Bar
 - Filler Bar
 - Gravity
 - Mounting Brackets
 Door Guards
 Dust Proof Strike
 Fire Bolts
 Flush Bolts
 - Automatic
 - Combination
 - Lever Extension
 - Residential
 - Self Latching
 Latches
 - Roller
 - Hospital
 - Gate
 Pivots
 Protection Plates
 Rabbet Guides
 Silencers
 Surface Bolts

F1 - F18 Section F — Auxiliary Hardware
 Catches
 Coat Hooks
 Door Knockers
 Door Viewers
 Engraved Signs
 Filler Plates
 Hand Rail Brackets
 Latch Adapter Plate
 Pulls
 - Ball Knob
 - Cast Flush
 - Cast Lever Edge
 - Concealed Edge
 - Flush Cup
 - Pocket
 - Utility
 - Wire
 - Wrought Flush
 Shims
 Tactile Signage with Braille

No.	Description	Page
10	Push BarA2
11	Push BarA2
12	Push BarA2
14	Push BarA3
15	Push BarA3
18	Push BarA3
18BFB	Bottom Fire Bolt - Metal DoorE17
19	Push BarA3
19BFB	Bottom Fire Bolt - Wood DoorE17
20	Pull BarA4
21	Pull BarA4
22	Pull BarA4
23	Pull BarA4
25	Push BarA5
26	Push BarA5
27	Push Pull Bar SetA5
28	Push Pull Bar SetA5
29	Push Pull Bar SetA5
30	Push Pull Bar SetA5
31	Pull BarA6
32	Pull BarA6
33	Push BarA6
34	Push BarA6
35	Push Pull Bar SetA6
36	Push Pull Bar SetA6
40	Screen Door GuardA7
41	Screen Door GuardA7
42	Screen Door GuardA7
43	Push BarA8
44	Push BarA8
45	Push BarA8
47 Series	Series 47 Push BarA11
48	Series 47 Push BarA11
50	Pull BarA9
51	Push BarA9
52	Push Pull Bar SetA9
70 Series	Push Plate - .050"B2
71 Series	Push Plate - .062"B3
73 Series	Push Plate - .125"B4
73BL	Concealed Mount Push PlateB16
73CL	Concealed Mount Push PlateB16
74 Series	Push Plate - .188"B5
75 Series	Push Plate - .125"B5
76 Series	Decorative Push Plate - .050"B6
77 Series	Decorative Push Plate - .050"B6
80	Push Plate - .050"B6
81	Push Plate - .050"B6
82	Push Plate - .050"B6
84	Push Plate - .050"B6
85	Push Plate - .050"B7
86	Push Plate - .050"B7
87	Push Plate - .125"B7
90	Cylinder PullB8
90B	Cylinder PullB8
91	Combination Push Pull PlateB8
92	Combination Push Pull PlateB8
93	Combination Push Pull PlateB8
94	Flush PullB9
94BTB	Flush PullB9
94C	Flush PullB9
94DLL	Dead Lock Flush PullB9
94DLS	Dead Lock Flush PullB9

No.	Description	Page
94L	Flush PullB10
94P	Flush PullB10
94P x 94L	Flush Pull SetB10
95A	Flush PullB11
95B	Flush PullB11
95R	Flush Pull - RoundB11
96	Flush PullB12
102	Straight Door PullB14
102 x 70	Pull PlateB23
105	Straight Door PullB14
105 x 70	Pull PlateB23
106	Straight Door PullB14
106 x 70	Pull PlateB23
107	Straight Door PullB14
107 x 70	Pull PlateB23
108	Straight Door PullB14
109	Straight Door PullB14
110	Straight Door PullB14
110 x 70	Pull PlateB23
110-6SP	Security Door PullB16
111	Straight Door PullB14
111 x 70	Pull PlateB23
111A	Straight Door PullB14
112	Straight Door PullB14
118	Straight Door PullB14
120	Door PullB18
121	Door PullB18
122	Door PullB18
122 x 70	Pull PlateB24
123	Door PullB18
123 x 70	Pull PlateB24
125	Door PullB19
125 x 70	Pull PlateB24
126	Door PullB19
126 x 70	Pull PlateB24
130	Cast Door PullB19
131	Cast Door PullB19
132	Cast Door PullB20
132 x 70	Pull PlateB25
134	Cast Door PullB20
137	Cast Door PullB21
137 x 70	Pull PlateB25
137L	Cast Door PullB21
138	Cast Door PullB21
139	Cast Door PullB21
147	Door PullB22
147 x 76	Pull PlateB26
147 x 77	Pull PlateB26
147L	Door PullB22
148	Door PullB22
148 x 76	Pull PlateB26
148 x 77	Pull PlateB26
149	Door PullB22
176	Offset Door PullB33
177	Offset Door PullB33
185	Offset Door PullB33
193	Hospital Door PullB34
208	Wooden Door PullB34
215	Tapered Door PullB34
215L	Tapered Door PullB34
290	Corner GuardC24
291	Corner GuardC24

No.	Description	Page
295	Corner Guard	.C24
296	Corner Guard	.C24
300	Mortise Door Edge	.C8
301	Mortise Door Edge	.C8
302	Mortise Door Edge	.C8
302B	Mortise Door Edge	.C8
304	Non-Mortise Door Edge	.C9
305	Non-Mortise Door Edge	.C9
306	Non-Mortise Door Edge	.C9
306-AST	Non-Mortise Door Edge	.C9
306B	Non-Mortise Door Edge	.C9
306B-AST	Non-Mortise Door Edge	.C9
307	Non-Mortise Door Edge	.C9
308	Overlapping Door Edge	.C12
309	Overlapping Door Edge	.C12
310	Overlapping Door Edge	.C12
310B	Overlapping Door Edge	.C12
310BS	Overlapping Door Edge	.C12
310S	Overlapping Door Edge	.C12
320	Latch Protector	.C25
320C	Latch Protector	.C25
320CL	Latch Protector	.C25
321	Latch Protector	.C26
322	Latch Protector	.C26
400	Solid Cast Wall Stop	.D1
401	Solid Cast Wall Stop	.D1
402	Solid Cast Wall Stop	.D1
403	Solid Cast Wall Stop	.D1
404	Solid Cast Wall Stop	.D1
405	Solid Cast Wall Stop	.D1
406	Wrought Wall Stop	.D2
407	Wrought Wall Stop	.D2
408	Wrought Wall Stop	.D2
409	Wrought Wall Stop	.D2
410	Wrought Wall Stop	.D2
411	Wrought Wall Stop	.D2
415	Solid Cast Wall Stop	.D1
426	Wall Stop	.D2
430	Solid Cast Wall Stop	.D3
431	Wall Stop	.D3
432W	Wall Stop	.D3
440	Low Dome Stop	.D4
441	Low Dome Stop	.D4
441CU	Dome Stop Combination Unit	.D4
441H	Cast Universal Dome Stop	.D4
442	High Dome Stop	.D5
443	High Dome Stop	.D5
444	Cast Door Stop Riser	.D4
445	Heavy Duty Door Stop	.D5
446	Door Stop	.D5
449	Door Stop Riser	.D5
455	Curved Roller Stop	.D6
456	Straight Roller Stop	.D6
456L	Straight Roller Stop	.D6
458	Kick Down Door Stop	.D7
459	Spring Loaded Plunger Stop	.D7
460	Kick Down Door Stop	.D7
461	Kick Down Door Stop	.D8
461L	Kick Down Door Stop	.D8
462	Heavy Duty Door Stop	.D9
463	Heavy Duty Door Stop	.D9
464	Heavy Duty Door Stop w/Holder	.D9

No.	Description	Page
465	Heavy Duty Door Stop	.D10
466	Heavy Duty Door Stop	.D10
467	Heavy Duty Door Stop	.D10
470	Door Stop	.D11
471	Door Stop	.D11
472	Door Stop w/Keeper	.D11
473	Door Stop w/Keeper	.D11
474	Door Stop	.D12
475	Door Stop	.D12
476	Door Stop w/Keeper	.D12
477	Door Stop w/Keeper	.D12
480	Door Stop	.D13
480H	Door Stop	.D13
481	Door Stop	.D13
481H	Door Stop	.D13
481MP	Heavy Duty Mounting Plate	.D13
482	Door Stop	.D14
483	Door Stop	.D14
485	Door Stop w/Keeper	.D14
486	Angle Door Stop	.D15
487	Heavy Duty Wall Stop	.D15
488	Door Stop	.D15
489	Door Stop	.D15
490	Door Holder & Stop	.D16
491	Automatic Door Holder & Stop	.D16
491R	Automatic Door Holder & Stop	.D16
491S	Automatic Door Holder & Stop	.D16
494	Automatic Door Holder & Stop	.D17
494R	Automatic Door Holder & Stop	.D17
494S	Automatic Door Holder & Stop	.D17
505	Door Stop	.D18
508	Door Stop	.D18
517	Aluminum Door Stop	.D18
518	Door Stop	.D18
519	Door Stop	.D18
520	Replacement Bumper	.D18
525	Spring Base Door Stop	.D19
526	Spring Base Door Stop	.D19
528	Hinge Pin Stop	.D19
550	Lever Extension Flush Bolt	.E1
554	Rabbit Piece	.E1
554G	Rabbit Guide	.E1
554S	Rabbit Guide	.E1
555	Lever Extension Flush Bolt	.E2
555 x 18BFB	Lever Extension Flush Bolt w/Bottom Fire Bolt	.E2
557	Lever Extension Flush Bolt	.E3
557 x 19BFB	Lever Extension Flush Bolt w/Bottom Fire Bolt	.E3
570	Dust Proof Strike	.E4
576	Gravity Door Coordinator	.E4
580 Series	Surface Bolts	.E5
582 Series	Surface Bolts	.E5
585 Series	Heavy Duty Surface Bolts	.E5
590	Roller Latch w/Cast Strike	.E6
590DA	Roller Latch w/Double Acting Strike	.E6
591	Roller Latch w/ASA Strike	.E6
592	Roller Latch w/#161 Strike	.E7
593	Roller Latch w/Angle Strike	.E7
594	Roller Latch w/161 Strike	.E7
596 Series	Hospital Push Pull Latch	.E8
602	Secret Gate Latch	.E9
603	Door Guard w/Shim	.E9
604	Door Guard w/Shim	.E9

No.	Description	Page
605	Door Guard Protection Plate	E9
605SMS	Door Guard Protection Plate	E9
606	Door Guard Protection Plate	E10
607	Privacy Door Guard	E10
608	Door Silencer	E10
608CA	Door Silencedr	E10
609	Door Silencer	E10
611	Door Knocker	F1
614	Door Knocker	F1
614V	Door Knocker w/Viewer	F1
619	160° Door Viewer	F1
620	160° Door Viewer	F1
620VC	Door Viewer Cover	F1
621	160° Door Viewer	F1
622	190° Door Viewer	F2
622VC	Door Viewer Cover	F2
624	160° Door Viewer w/Cover	F1
626	190° Door Viewer w/Cover	F2
630 Series	Surface Bolts	E11
640	Residential Flush Bolt	E11
640RE	Residential Flush Bolt	E11
651	Card Holder	F2
660	Decal	F2
670	Engraved Sign - SPECIFY COPY	F3
670M	Engraved Sign - MEN	F3
670R	Engraved Sign - RESTROOM	F3
670W	Engraved Sign - WOMEN	F3
674H	Engraved Sign - PUSH	F3
674L	Engraved Sign - PULL	F3
700	Hand Rail Bracket	F7
701	Hand Rail Bracket	F7
702	Hand Rail Bracket	F7
790	Small Coat Hook	F8
796	Small Double Coat Hook	F8
802	Medium Coat Hook	F8
806	Medium Coat Hook	F8
841	Ball Knob	F9
845	Utility Pull	F9
850	Solid Wire Pull	F9
851	Solid Wire Pull	F9
852	Solid Wire Pull	F9
853	Solid Wire Pull	F9
856	Heavy Wire Pull	F9
860	Flush Cup Pull	F10
870	Wrought Flush Pull	F10
872	Cast Flush Pull	F10
880	Cast Lever Edge Pull	F11
885	Concealed Edge Pull	F11
890	Pocket Door Pull	F11
891	Pocket Door Privacy Latch	F11
900	Magnetic Catch	F12
901	Magnetic Catch	F12
910	Adjustable Ball Catch	F13
910RC	Adjustable Ball Catch	F13
911	Adjustable Ball Catch	F13
911RC	Adjustable Ball Catch	F13
1100	Carry Bar	E13
1600 Series	Door Coordinators	E12
1601AB	Mounting Bracket	E13
1601C	Mounting Bracket	E13
1700	Door Coordinator	E13
1805	Self Latching Flush Bolt (top bolt only)	E14

No.	Description	Page
1840	Automatic Flush Bolt (top bolt only)	E14
1842	Automatic Flush Bolt Set	E14
1845	Self Latching Flush Bolt Set	E14
1848	Automatic Flush Bolt Set	E16
1849	Self Latching Flush Bolt (w/bottom fire bolt)	E19
1905	Self Latching Flush Bolt (top bolt only)	E15
1940	Automatic Flush Bolt (top bolt only)	E15
1942	Automatic Flush Bolt Set	E15
1945	Self Latching Flush Bolt Set	E15
1948	Automatic Flush Bolt Set	E16
1949	Self Latching Flush Bolt (w/bottom fire bolt)	E19
1960	Automatic Flush Bolt (w/bottom fire bolt)	E18
1962	Automatic Flush Bolt Set	E18
11000 Series	Concealed Overhead Holder & Stop	D20
11047	Straight Push Pull Bar Set	A13
11047-2	Straight Push Pull Bar Set	A14
11047-3	Straight Push Pull Bar Set	A15
111A47	Straight Push Pull Bar Set	A13
111A47-2	Straight Push Pull Bar Set	A14
111A47-3	Straight Push Pull Bar Set	A15
11147	Straight Push Pull Bar Set	A13
11147-2	Straight Push Pull Bar Set	A14
11147-3	Straight Push Pull Bar Set	A15
11247	Straight Push Pull Bar Set	A13
11247-2	Straight Push Pull Bar Set	A14
11247-3	Straight Push Pull Bar Set	A15
11847	Straight Push Pull Bar Set	A13
14000 Series	Concealed Overhead Holder & Stop	D21
14400 Series	Surface Overhead Holder & Stop	D22
17000 Series	Surface Overhead Holder & Stop	D23
19000 Series	Surface Overhead Holder & Stop	D24
BF97	Barrier Free Flush Pull	B12
BF97L	Barrier Free Flush Pull	B12
BF150	90° Offset Door Pull	B28
BF151	90° Offset Door Pull	B28
BF152	90° Offset Door Pull	B28
BF156	90° Offset Door Pull	B28
BF15647	Offset Push Pull Bar Set	A16
BF15647-2	Offset Push Pull Bar Set	A17
BF15647-3	Offset Push Pull Bar Set	A18
BF157	90° Offset Door Pull	B28
BF157A	90° Offset Door Pull	B28
BF157A47	Offset Push Pull Bar Set	A16
BF157A47-2	Offset Push Pull Bar Set	A17
BF157A47-3	Offset Push Pull Bar Set	A18
BF15747	Offset Push Pull Bar Set	A16
BF15747-2	Offset Push Pull Bar Set	A17
BF15747-3	Offset Push Pull Bar Set	A18
BF158	90° Offset Door Pull	B28
BF15847	Offset Push Pull Bar Set	A16
BF15847-2	Offset Push Pull Bar Set	A17
BF15847-3	Offset Push Pull Bar Set	A18
BF159	90° Offset Door Pull	B28
BF15947	Offset Push Pull Bar Set	A16
BF160	45° Offset Door Pull	B31
BF161	45° Offset Door Pull	B31
BF162	45° Offset Door Pull	B31
BF166	45° Offset Door Pull	B31
BF167A	45° Offset Door Pull	B31
BF167	45° Offset Door Pull	B31
BF168	45° Offset Door Pull	B31
BF169	45° Offset Door Pull	B31

No.	Description	Page
BF257	Heavy Duty Offset Door Pull	.B32
BF258	Heavy Duty Offset Door Pull	.B32
BF259	Heavy Duty Offset Door Pull	.B32
BF260	Heavy Duty Offset Door Pull	.B32
BF680	Engraved Sign w/Braille - SPECIFY COPY	.F4
BF680M	Engraved Sign w/Braille - MEN	.F4
BF680R	Engraved Sign w/Braille - RESTROOM	.F4
BF680W	Engraved Sign w/Braille - WOMEN	.F4
BF683	Tactile ADA Sign w/Braille	.F5
BF684	Tactile ADA Sign w/Braille	.F5
BF685	Tactile ADA Sign w/Braille	.F5
BF686	Tactile ADA Sign w/Braille	.F5
BF687	Tactile ADA Sign w/Braille	.F5
BF688	Tactile ADA Sign w/Braille	.F5
BF689	Tactile ADA Sign w/Braille	.F5
BFLG10	Latch Guard Cover	.C21
BFLG12	Latch Guard Cover	.C21
BFLG16	Latch Guard Cover	.C21
BFM682	Tactile ADA Molded Plastic Sign w/Braille	.F6
BFM684	Tactile ADA Molded Plastic Sign w/Braille	.F6
BFM685	Tactile ADA Molded Plastic Sign w/Braille	.F6
BFM686	Tactile ADA Molded Plastic Sign w/Braille	.F6
BFM687	Tactile ADA Molded Plastic Sign w/Braille	.F6
BFM688	Tactile ADA Molded Plastic Sign w/Braille	.F6
BFM689	Tactile ADA Molded Plastic Sign w/Braille	.F6
BFRC12	Vertical Rod Cover	.C21
BFRC24	Vertical Rod Cover	.C21
BP47 Series	Series 47 Push Bar w/Base Plate	.A12
BP47-2	Series 47 Push Bar w/Base Plate	.A12
BP47-3	Series 47 Push Bar w/Base Plate	.A12
CP10 Series	Standard Head Pivot	.E20
CP20 Series	Standard Head Pivot	.E20
CP40 Series	Standard Floor Pivot	.E21
CP50 Series	Standard Floor Pivot	.E21
CPK1840	Cover Plate Kit	.E17
CS Series	Custom Strikes	.C22
D89	Security Flush Pull	.B8
D133	Security Loop Door Pull	.B20
DF86	Door Edge Filler Plate	.F14
DFF4	Frame Hinge Filler Plate	.F14
DFF5	Frame Hinge Filler Plate	.F14
DHF4B	Beveled Door Hinge Filler Plate	.F14
DHF4S	Square Door Hinge Filler Plate	.F15
DHF5B	Beveled Door Hinge Filler Plate	.F15
DHF5S	Square Door Hinge Filler Plate	.F15
FB-1	Filler Bar	.E13
FB-2	Filler Bar	.E13
FBF48	Flush Bolt Filler Plate	.F15
FBS48	Flush Bolt Strike Filler Plate	.F16
FC161	Door Face Filler Plate	.F16
FD160	Door Face Filler Plate	.F16
HD2230	Heavy Duty Trim Protector Bar	.C17
HD2230M	Heavy Duty Trim Protector Bar	.C17
HD2240	Heavy Duty Trim Protector Bar	.C17
HD2240M	Heavy Duty Trim Protector Bar	.C17
HD2250	Heavy Duty Trim Protector Bar	.C17
HD2250M	Heavy Duty Trim Protector Bar	.C17
HS42	4½" Hinge Shim - .028"	.F16
HS44	4½" Hinge Shim - .065"	.F17
HS52	5" Hinge Shim - .028"	.F17
HS54	5" Hinge Shim - .065"	.F17

No.	Description	Page
K1038	Metal Door Plate - .038"	.C1
K1050	Metal Door Plate - .050"	.C1
K1050-1-K1050-8	Shaped Door Plates - .050"	.C2
K1050A-1-K1050A-8	Shaped Door Plates - .050"	.C3
K1050F	Metal Door Plate - .050"	.C1
K1062	Metal Door Plate - .062"	.C4
K1125	Metal Door Plate - .125"	.C4
K2060	Plastic Door Plate - .060"	.C5
K2125	Plastic Door Plate - .125"	.C5
K3125	Laminate Plastic Door Plate - .125"	.C6
K4125	Clear Plastic Door Plate - .125"	.C6
KB1150	Angle Plate - .050"	.C7
KB1151	Angle Plate - .050"	.C7
KB1152	Angle Plate - .050"	.C7
LA86	Latch Adapter Plate	.F17
LF161	Door Edge Filler Plate	.F18
R101LPB	Trim Protector Bar	.C19
R102LPB	Trim Protector Bar	.C19
R111LPB	Trim Protector Bar	.C19
R112LPB	Trim Protector Bar	.C19
R115LPB	Trim Protector Bar	.C19
R116EDPH	Exit Device Protector	.C20
R116EDPL	Exit Device Protector	.C20
SD1230	Standard Duty Trim Protector Bar	.C18
SD1240	Standard Duty Trim Protector Bar	.C18
SD1250	Standard Duty Trim Protector Bar	.C18
SD1260	Standard Duty Trim Protector Bar	.C18
SF160	Strike Filler Plate	.F18
SFASA	Strike Filler Plate	.F18
SFB160	Strike Filler Plate	.F18
SP47	Series 47 Push Bar	.A11
T47 Series	Tubular Push Bars	.A19
T110 - T112	Tubular Straight Door Pulls	.B15
T118	Tubular Straight Door Pulls	.B15
T11047	Straight Tubular Single Bar Sets	.A20
T111A47	Straight Tubular Single Bar Sets	.A20
T11147	Straight Tubular Single Bar Sets	.A20
T11247	Straight Tubular Single Bar Sets	.A20
T11847	Straight Tubular Single Bar Sets	.A20
TBF156	Tubular 90° Offset Door Pulls	.B9
TBF157A	Tubular 90° Offset Door Pulls	.B29
TBF157	Tubular 90° Offset Door Pulls	.B29
TBF158	Tubular 90° Offset Door Pulls	.B29
TBF159	Tubular 90° Offset Door Pulls	.B29
TBF15647	Offset Tubular Single Bar Sets	.A21
TBF157A47	Offset Tubular Single Bar Sets	.A21
TBF15747	Offset Tubular Single Bar Sets	.A21
TBF15847	Offset Tubular Single Bar Sets	.A21
TBF15947	Offset Tubular Single Bar Sets	.A21
VRT12	Vandal Resistant Trim	.B32
VRT22	Vandal Resistant Trim	.B32
Y102 - Y112	Door Pull w/Base Plate	.B17
Y118	Door Pull w/Base Plate	.B17
YBF150	90° Offset Door Pull w/Base Plate	.B30
YBF151	90° Offset Door Pull w/Base Plate	.B30
YBF152	90° Offset Door Pull w/Base Plate	.B30
YBF156	90° Offset Door Pull w/Base Plate	.B30
YBF157A	90° Offset Door Pull w/Base Plate	.B30
YBF157	90° Offset Door Pull w/Base Plate	.B30
YBF158	90° Offset Door Pull w/Base Plate	.B30
YBF159	90° Offset Door Pull w/Base Plate	.B30

Most of Rockwood's products are available in all of the following architectural finishes. The catalog indicates exceptions. This finish list is grouped by base metal.

Base Metal	Description	Rockwood Code	BHMA Code
Aluminum	Satin	US27	627
Aluminum	Clear Anodized	US28	628
Aluminum	Light Bronze Anodized	311	—
Aluminum	Medium Bronze Anodized	312	—
Aluminum	Dark Bronze Anodized	313	710
Aluminum	Extra Dark Bronze Anodized	314	—
Aluminum	Black Anodized	315	711
Aluminum	White Powder Coat	WPC	—
Aluminum	Red Powder Coat	RPC	—
Aluminum	Black Powder Coat	BPC	—
Brass	Polished Clear Coated	US3	605
Brass	Polished No Coating	US3NL	—
Brass	Satin Clear Coated	US4	606
Brass	Satin Oxidized Relieved	US5	609
Brass	Satin Nickel Plated Clear Coated	US15	619
Brass	Satin Nickel Blackened Relieved Clear Coated	US15A	620
Brass	Flat Black Powder Coated	US19	622
Brass	Polished Chrome Plated	US26	625
Brass	Satin Chrome Plated	US26D	626

Base Metal	Description	Rockwood Code	BHMA Code
Bronze*	Polished Clear Coated	US9	611
Bronze	Satin Clear Coated	US10	612
Bronze	Satin Oxidized Oil Rubbed	US10B	613
Bronze	Satin Oxidized Clear Coated	US10BL	614
Bronze	Satin Dark Statuary	US20A	624
Stainless Steel	Polished	US32	629
Stainless Steel	Satin	US32D	630
Special Finishes (see descriptions below)			
Stainless Steel	Satin MicroShield™ Coated	US32D M5 **	—
Stainless Steel	Polished 316 Alloy	US32 316 **	—
Stainless Steel	Satin 316 Alloy	US32D 316 **	—
Stainless Steel	PVD Polished Brass	US3 LIFETIME	—
Brass	PVD Polished Brass	US3 LIFETIME	—

US32DM5**** (MicroShield®): As part of its promise to provide innovative solutions to their customers, ASSA ABLOY Group companies offer the MicroShield® technology, a silver-based antimicrobial coating designed to stem the spread of germs and bacteria.

US32316**** and **US32D**316****: Made from alloy 316 stainless steel containing molybdenum and extra nickel giving it substantially higher corrosion resistance than the standard stainless steels typically used in door hardware. This finish is ideal for use in coastal, urban, and industrial areas that have harsh environmental conditions.

US3LIFETIME****: A PVD (physical vapor deposition) finish on either stainless steel or chrome plated brass base material. The finish is a thin hard metallic film of extreme durability that looks like polished brass. **US3**LIFETIME**** brass finish will not tarnish and is ideal for use in exterior and marine environments.

* On most bronze finishes we will supply solid bronze material. Where solid bronze material is not available, we will use brass as a base material in its place.

** Available on select items as indicated by the finish icon throughout the catalog.



MicroShield® is a registered trademark of Yale Security Inc., an ASSA ABLOY Group company.

Polished Brass

Polished brass is a beautiful finish that does not normally weather very well outdoors. Rockwood uses a very durable baked on clear powder coat on most door pulls and push bars. In indoor usage, this finish is extremely durable. For a guaranteed no tarnish finish for outdoor use, specify our US3**LIFETIME** finish.

Stainless Steel

Stainless steel is one of the most durable materials used in architecture; however there are many types with different properties and different levels of corrosion resistance. In most indoor (except chlorine and other harsh chemical exposure) and many outdoor (mildly corrosive) environments our standard stainless steel will perform exceeding well. It is best maintained by periodic water washing. If your job site has road salt, marine salt air, industrial, or urban pollution, we recommend the use of molybdenum bearing alloy 316 stainless steel. Specify US32**316** or US32D**316**.

Stainless Steel

To enhance the corrosion resistance of stainless steel, use the polished finish (US32) in place of the satin finish (US32D). Minute particles of dirt and debris can lodge in the microscopic crevices of the satin finish more readily than on a smooth surface promoting corrosion. The mirror smooth surface of the polished finish has no rough surface to retain microscopic dirt or debris.

Heat Resistant

Exterior hot sunny climates call for a finish that is resistant to heat. We recommend our white powder coat finish (WPC). This durable exterior finish reflects much of the heat rays and is substantially cooler to the touch than stainless steel or other finishes.

Bacterial Protection

MicroShield® (US32DMS) is the ideal finish for hospitals, schools, laboratories, assisted living facilities, public restroom areas, and anywhere there is a concern to control bacterial growth for demanding standards of cleanliness. Contact our customer service department for more detailed information.

Finish Sample Displays

Educational and informative displays are available showing our most popular finishes.



ROCKWOOD

ASSA ABLOY

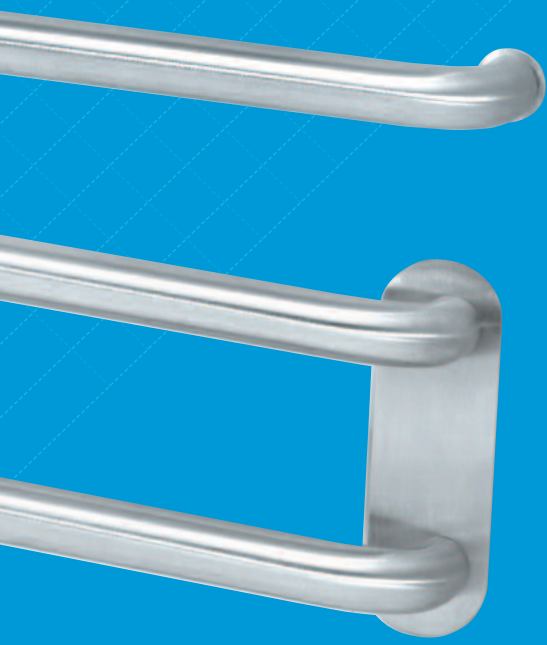

**A - Push and Pull Bars
from Rockwood**

Strength and Style

Guaranteed Mounting Systems

Beautiful Finishes

Custom Fabrication

ASSA ABLOY, the global leader
in door opening solutions

Push and Pull Bar Mounting Details

Sizing of Push Bars

Flush Doors

Door width:

- minus 5" for bent end bars
- minus 5" for square end post mount bars
- minus 7" for round end post mount bars

Stile and Rail Doors or Doors with Lites

Door width:

- minus width of one stile

CAUTION: Always confirm bars will not interfere with jamb or cause pinching hazard.

CAUTION: On narrow stile doors, be sure push bar base fits on the stile and bar does not interfere with the stop.

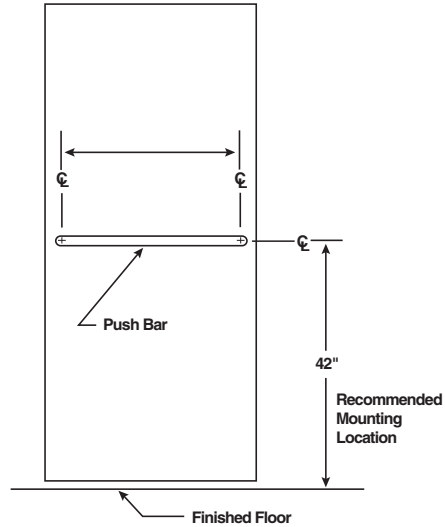

Handing of Doors

The handing of a door is determined from the outside of the opening.

Standing outside the door:

- If the hinges are on the right, it is a right hand door.
- If the hinges are on the left, it is a left hand door.
- If the door opens away from you, it is a regular bevel door.
- If the door opens toward you, it is a reverse bevel door.

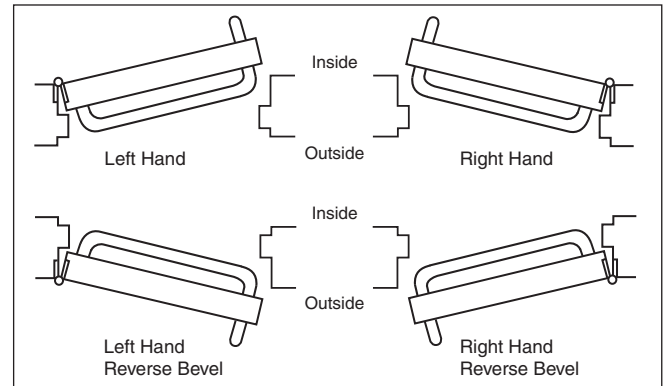

Mounting Types for Push Bars #10 through #45 and #50, #51, #52

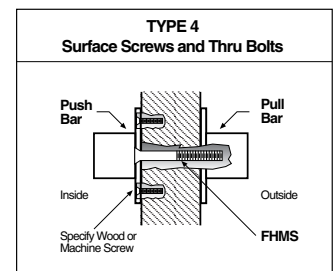
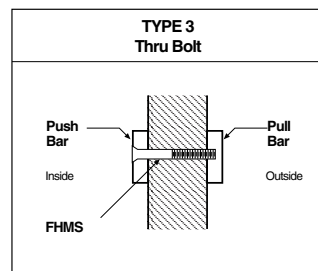
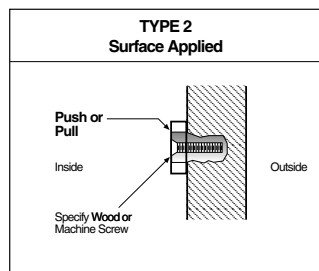
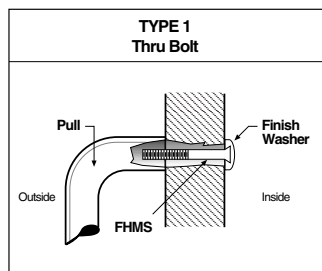

**Push Bar
 No. 10**



- Material:** Brass, Bronze
- Finishes:** Available in standard architectural finishes (see page 7).
- Mounting:** Metal Door: Type 2, Surface, 8-32 x 3/4 OHMS
 Wood Door: Type 2, Surface, #8 x 3/4 OHSMS
- Ordering:** Specify CTC, door type, mounting, and finish.
- Features:** Can be field cut if necessary.

No.	Material Size	Base	Projection	Clearance	Weight	ANSI A156.6
10	3/8" x 1 1/2"	1 1/2" x 2 7/8"	1 1/4"	5/8"	6.9 lbs.	J501

**Push Bars
 No. 11, 12**



- Material:** Aluminum, Brass, Bronze, Stainless Steel
- Finishes:** Available in standard architectural finishes, except US32 (see page 7).
- Mounting:** No. 11
 Metal Door: Type 2, Surface, 1/4-20 x 1 1/2 MS & 8-32 x 3/4 OHMS
 Wood Door: Type 2, Surface, #12 x 3/4 WS & #8 x 3/4 OHSMS
- No. 12
 Metal & Wood Door: Type 1, 1/4-20 x 2 1/4 Thru Bolt & Finish Washer (standard 1 3/4" door)
- Ordering:** Specify CTC, door type, mounting, and finish.
- Options:** Advise if door thickness is other than 1 3/4".

No.	Material Size	Base	Projection	Clearance	Weight	ANSI A156.6
11	3/8" x 1 1/2"	1" x 3" x 1/8"	2"	1 5/8"	6.2 lbs.	J501
12 (less base plate)	3/8" x 1 1/2"	3/8" x 1 1/2"	1 7/8"	1 1/2"	6.2 lbs.	J501

**Push Bars
No. 14, 15**



- Material:** Aluminum, Brass, Bronze, Stainless Steel
- Finishes:** Available in standard architectural finishes, except US32 (see page 7).
- Mounting:** Metal & Wood Door: Type 1, 1/4"-20 x 2 1/4" Thru Bolt & Finish Washer (standard 1 3/4" door).
- Ordering:** Specify CTC, door type, mounting, and finish.
- Options:** Advise if door thickness is other than 1 3/4".

No.	Material Size	Base	Projection	Clearance	Weight	ANSI A156.6
14	3/8" x 1 1/2"	1 1/2" x 2 x 1/8"	2"	1 5/8"	6.3 lbs.	J501
15 (less base plate)	3/8" x 1 1/2"	3/8" x 1 1/2"	1 7/8"	1 1/2"	6.1 lbs.	J501

**Push Bars
No. 18, 19**



- Material:** Aluminum, Brass, Bronze, Stainless Steel
- Finishes:** Available in standard architectural finishes, except US32 (see page 7).
- Mounting:**
 - No. 18
Metal Door: Type 2, Surface, 1/4"-20 x 1 & 8-32 x 3/4" OHMS
Wood Door: Type 2, Surface, #12 x 1 1/4" FHWS & #8 x 3/4" OHSMS
 - No. 19
Metal Door: Type 1, Thru Bolt, 1/4"-20 x 1 OHMS
Wood Door: Type 1, Thru Bolt, #12 x 1 1/4" FHWS, Finish Washer
- Ordering:** Specify CTC, door type, mounting, and finish.
- Options:** Advise if door thickness is other than 1 3/4".

No.	Material Size	Base	Projection	Clearance	Weight	ANSI A156.6
18	3/8" x 1 1/2"	1" x 3 x 1/8"	2 1/8"	1 3/4"	6.2 lbs.	J501
19 (less base plate)	3/8" x 1 1/2"	3/8" x 1 1/2"	2"	1 5/8"	6.2 lbs.	J501

**Pull Bars
No. 20, 21**

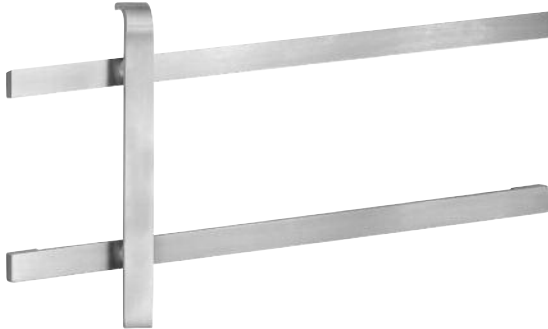

- Material:** Aluminum, Brass, Bronze, Stainless Steel
- Finishes:** Available in standard architectural finishes, except US32 (see page 7).
- Mounting:** Metal & Wood Door: Type 1, ¼-20 x 2¼ Thru Bolt & Finish Washer (standard 1¾" door).
- Ordering:** Specify CTC, door type, and finish.
- Options:**
- Ideal for engraving.
 - Advise if door thickness is other than 1¾".

No.	Material Size	Base	Projection	Clearance	Space	Weight	ANSI A156.6
20	⅜" x 1¼"	1½" x 1¼"	2¼"	1⅞"	8"	12.3 lbs.	J502
21	⅜" x 1½"	1½" x 1½"	2¼"	1⅞"	8"	14.7 lbs.	J502

**Pull Bars
No. 22, 23**

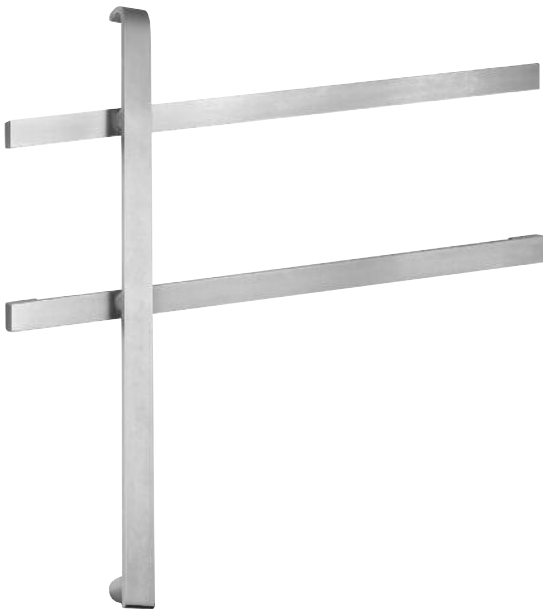

- Material:** Aluminum, Brass, Bronze, Stainless Steel
- Finishes:** Available in standard architectural finishes, except US32 (see page 7).
- Mounting:** Metal & Wood Door: Type 1, ¼-20 x 2¼ Thru Bolt & Finish Washer (standard 1¾" door).
- Ordering:** Specify CTC, door type, and finish.
- Options:** Ideal for engraving.
- Other:**
- Pull length is 42" from top post to bottom post.
 - Advise if door thickness is other than 1¾".

No.	Material Size	Base	Projection	Clearance	Space	Weight	ANSI A156.6
22	⅜" x 1¼"	1½" x 1¼"	2¼"	1⅞"	8"	16.7 lbs.	J503
23	⅜" x 1½"	1½" x 1½"	2¼"	1⅞"	8"	20.0 lbs.	J503

**Push Bars
No. 25, 26**



Material: Aluminum, Brass, Bronze, Stainless Steel

Finishes: Available in standard architectural finishes, except US32 (see page 7).

Mounting: Metal & Wood Door: Type 1, 1/4-20 x 2 1/4 Thru Bolt & Finish Washer (standard 1 3/4" door).
Metal Door: Type 2, Surface, 1/4-20 MS
Wood Door: Type 2, Surface, #12 WS

Ordering: Specify CTC, door type, mounting, and finish.

Options: Advise if door thickness is other than 1 3/4".

No.	Material Size	Base	Projection	Clearance	Space	Weight	ANSI A156.6
25	3/8" x 1 1/4"	1 1/2" x 1 1/4"	3/4"	3/8"	—	4.8 lbs.	J501
26	3/8" x 1 1/2"	1 1/2" x 1 1/2"	3/4"	3/8"	—	5.8 lbs.	J501

**Push & Pull Bar Sets
No. 27, 28, 29, 30**

Material: Aluminum, Brass, Bronze, Stainless Steel

Finishes: Available in standard architectural finishes, except US32 (see page 7).

Mounting: Metal & Wood Door: Type 3, Back to Back, 1/4-20 MS

Ordering: Specify CTC, door type, and finish.

No.	Material Size	Space	Weight	ANSI A156.6
27	set consists of 1 #20 and 2 #25	8"	21.9 lbs.	J504
28	set consists of 1 #21 and 2 #26	8"	26.3 lbs.	J504
29	set consists of 1 #22 and 2 #25	8"	26.3 lbs.	J504
30	set consists of 1 #23 and 2 #26	8"	31.6 lbs.	J504

**Pull Bars
No. 31, 32**

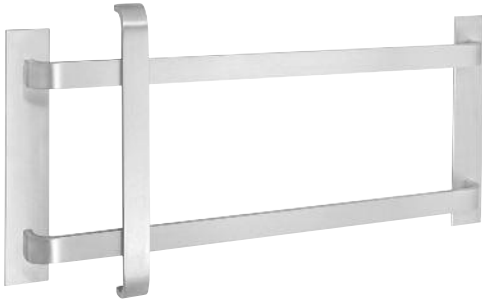

- Material:** Aluminum, Brass, Bronze, Stainless Steel
- Finishes:** Available in standard architectural finishes, except US32 (see page 7).
- Mounting:** Metal & Wood Door: Type 1, Thru Bolt, 1/4-20 x 2 1/4 FHMS, Finish Washers (standard 1 3/4" door).
- Ordering:** Specify CTC, door type, and finish.
- Options:**
- Ideal for engraving.
 - Advise if door thickness is other than 1 3/4".

No.	Material Size	Base	Projection	Clearance	Space	Weight	ANSI A156.6
31	3/8" x 1 1/4"	2" x 12" x 1/8"	2"	1 5/8"	8"	12.8 lbs.	J502
32	3/8" x 1 1/2"	2" x 12" x 1/8"	2"	1 5/8"	8"	15.4 lbs.	J502

**Push Bars
No. 33, 34**

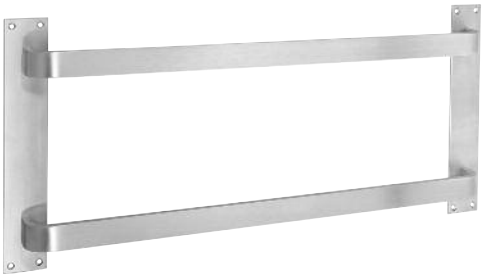

- Material:** Aluminum, Brass, Bronze, Stainless Steel
- Finishes:** Available in standard architectural finishes, except US32 (see page 7).
- Mounting:** Metal Door: Type 2, Surface, 8-32 x 3/4 OHMS
Wood Door: Type 2, Surface, #8 x 3/4 OHSMS
- Ordering:** Specify CTC, door type, mounting, and finish.
- Options:** Ideal for engraving.

No.	Material Size	Base	Projection	Clearance	Space	Weight	ANSI A156.6
33	3/8" x 1 1/4"	2" x 12" x 1/8"	1 5/8"	1 1/4"	8"	10.9 lbs.	J502
34	3/8" x 1 1/2"	2" x 12" x 1/8"	1 5/8"	1 1/4"	8"	13.1 lbs.	J502

**Push and Pull Bar Sets
No. 35, 36**

- Material:** Aluminum, Brass, Bronze, Stainless Steel
- Finishes:** Available in standard architectural finishes, except US32 (see page 7).
- Mounting:** Metal Door: Type 4, Back to Back, 1/4-20 x 2 1/4 & 8-32 x 3/4 OHMS
Wood Door: Type 4, Back to Back, 1/4-20 x 2 1/4 & #8 x 3/4 OHSMS
- Ordering:** Specify CTC, door type, mounting, and finish.

No.	Material Size	Space	Weight	ANSI 156.6
35	set consists of 1 #31 & 1 #33	8"	23.7 lbs.	J504
36	set consists of 1 #32 & 1 #34	8"	28.5 lbs.	J504

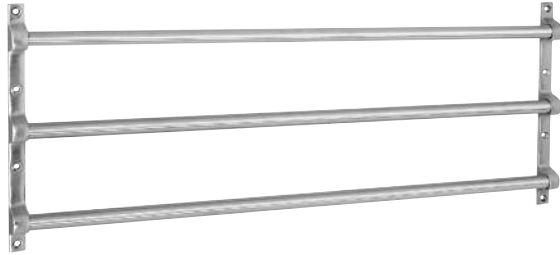

**Screen Door Guard
No. 40**

Material: Brass
Finishes: Available in standard architectural finishes (see page 7).
Mounting: Metal Door: Type 2, Surface, 8-32 x 3/4 OHMS
 Wood Door: Type 2 Surface, #8 x 3/4 OHSMS
Ordering: Specify CTC, door type, mounting, and finish.

No.	Material Size	Base	Projection	Clearance	Bar Space	Weight
40	5/8" tube	5/8" x 9 5/8"	1 1/8"	3/8"	3 1/2"	4.5 lbs.

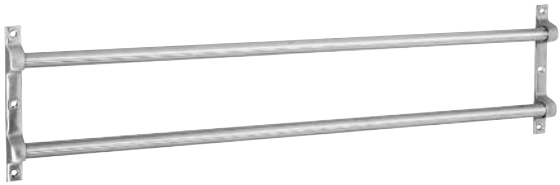

**Screen Door Guard
No. 41**

Material: Brass
Finishes: Available in standard architectural finishes (see page 7).
Mounting: Metal Door: Type 2, Surface, 8-32 x 3/4 OHMS
 Wood Door: Type 2 Surface, #8 x 3/4 OHSMS
Ordering: Specify CTC, door type, mounting, and finish.

No.	Material Size	Base	Projection	Clearance	Bar Space	Weight
41	5/8" tube	5/8" x 6 1/8"	1 1/8"	3/8"	3 1/2"	2.9 lbs.



**Screen Door Guard
No. 42**

Material: Brass
Finishes: Available in standard architectural finishes (see page 7).
Mounting: Metal Door: Type 2, Surface, 8-32 x 3/4 OHMS
 Wood Door: Type 2 Surface, #8 x 3/4 OHSMS
Ordering: Specify CTC, door type, mounting, and finish.

No.	Material Size	Base	Projection	Clearance	Bar Space	Weight
42	5/8" tube	5/8" x 2 5/8"	1 1/8"	3/8"	—	1.6 lbs.

**Push Bars
No. 43, 44**



Material: Aluminum, Brass, Bronze, Stainless Steel

Finishes: Available in standard architectural finishes, except US32 (see page 7).

Mounting: Metal & Wood Door: Type 1, 1/4-20 x 2 1/4 Thru Bolt & Finish Washer (standard 1 3/4" door).

Ordering: Specify CTC, door type, mounting, and finish.

Other: Ideal for engraving or logos.

Options: Advise if door thickness is other than 1 3/4".

No.	CTC	Material Size	Base	Projection	Clearance	Weight	ANSI 156.6
43	specify	3/8" x 3"	1 1/2" x 4 1/2" x 1/8"	2"	1 5/8"	10.5 lbs.	J501
44 (less base plate)	specify	3/8" x 3"	—	1 7/8"	1 1/2"	10.1 lbs.	J501

**Push Bar
No. 45**



Material: Aluminum, Brass, Bronze, Stainless Steel

Finishes: Available in standard architectural finishes, except US32 (see page 7).

Mounting: Metal & Wood Door: Type 1, 1/4-20 x 2 1/4 Thru Bolt & Finish Washer (standard 1 3/4" door).

Ordering: Specify CTC, door type, mounting, and finish.

Other: Ideal for engraving or logos.

Options: Advise if door thickness is other than 1 3/4".

No.	CTC	Material Size	Base	Projection	Clearance	Weight	ANSI 156.6
45	specify	3/8" x 3"	1 1/2" x 3"	3/4"	3/8"	9.9 lbs.	J501

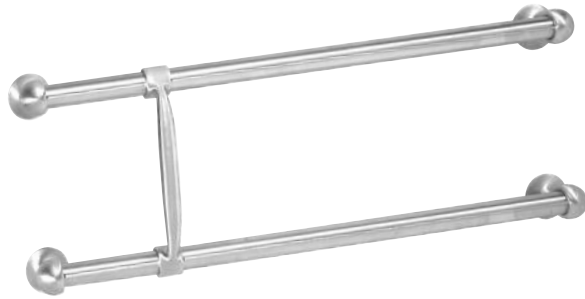

**Pull Bar
No. 50**

Material: Brass, Bronze

Finishes: Available in standard architectural finishes (see page 7).

Mounting: Metal & Wood Door: Type 1, ¼-20 x 2¼ Thru Bolt & Finish Washer (standard 1¾" door).
Wood Door: Type 2 Surface, #8 x ¾ OHSMS

Ordering: Specify CTC, door type, and finish.

Other: Cast slip-on end brackets.

Options: Advise if door thickness is other than 1¾".

No.	Material Size	Base	Projection	Clearance	Space	Weight	ANSI 156.6
50	1" dia.	2" dia.	3⅜"	2⅝"	7½"	7.6 lbs.	J502

**Push Bar and Door Pull
No. 51, 53**



Material: Brass, Bronze

Finishes: Available in standard architectural finishes (see page 7).

Mounting: Metal and Wood Door: Type 1, Thru Bolt, ¼-20 x 2¼ MS, Finish Washers (standard 1¾" door)
Metal Door: Type 2, Surface, 8-32 x ¾ OHMS
Wood Door: Type 2, Surface, #8 x ¾ OHSMS

Ordering: Specify door type, mounting, and finish.

Other: Cast slip-on end brackets.

Options: Advise if door thickness is other than 1¾".

No.	Material Size	CTC	Base	Projection	Clearance	Weight	ANSI 156.6
51	1" dia.	Specify	2" dia.	2⅜"	1¼"	3.1 lbs.	J501
53	1" dia.	12"	2" dia.	2⅜"	1¼"	1.5 lbs.	J401

**Push and Pull Bar Set
No. 52**

Material: Brass, Bronze

Finishes: Available in standard architectural finishes (see page 7).

Mounting: Metal Door: Type 4, Back to Back, ¼-20 x 2¼ MS & 8-32 x ¾ OHMS
Wood Door: Type 4, Back to Back, ¼-20 x 2¼ MS & #8 x ¾ OHSMS

Ordering: Specify CTC, door type, mounting, and finish.

Other: Cast slip-on end brackets.

No.	Material Size	Weight	ANSI 156.6
52	set consists of 1 #50 and 2 #51	30.9 lbs.	J504

Series 47 Push and Pull Bars Mounting Details

TYPICAL MOUNTING

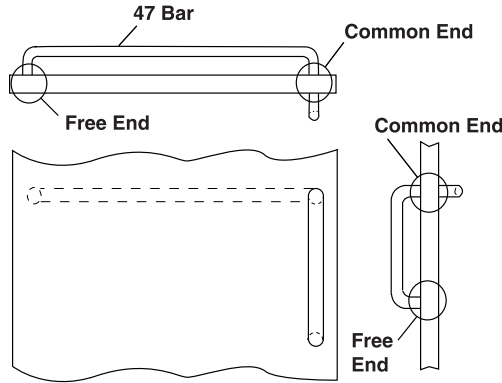

FREE END DETAILS

Thru Bolt

Wood or Metal Door - Type 1

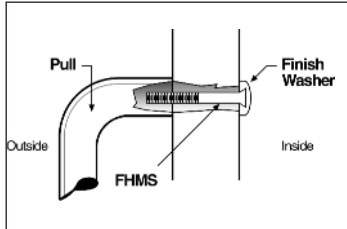

Type	Bolt Size	Drill Size	
		Wood	Metal
1	1/4 - 20	9/32	9/32
1HD	5/16 - 18	11/32	11/32
1XHD	3/8 - 16	13/32	13/32

Wood or Metal Door - Type 12

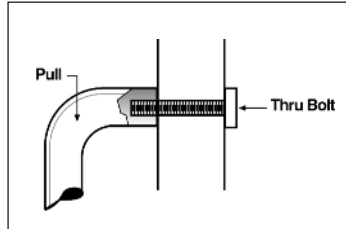

Type	Bolt Size	Drill Size	
		Wood	Metal
12	1/4 - 20	9/32	9/32
12HD	5/16 - 18	11/32	11/32
12XHD	3/8 - 16	13/32	13/32

Glass Door - Type 15

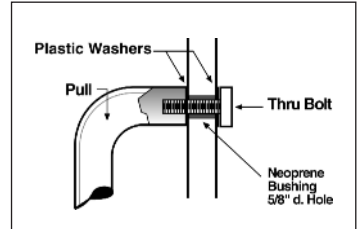

Type	Bolt Size	Drill Size - Glass
15	1/4 - 20	5/8
15HD	5/16 - 18	5/8
15XHD	3/8 - 16	5/8

Surface Concealed

Metal Door - Type 6

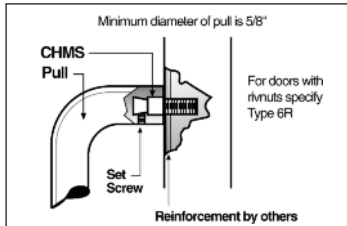

Type	Bolt Size	Drill Size - Metal
6	1/4 - 20	1/4-20 tap
6HD	5/16 - 18	5/16-18 tap

Wood Door - Type 8

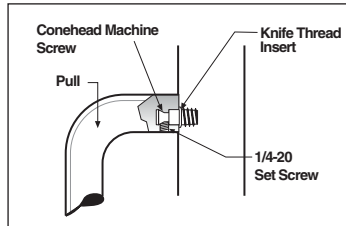

Type	Bolt Size	Drill Size - Wood
8	1/4 - 20	23/64 X 9/16 dp
8HD	5/16 - 18	7/16 X 9/16 dp

Metal Door - Type 17

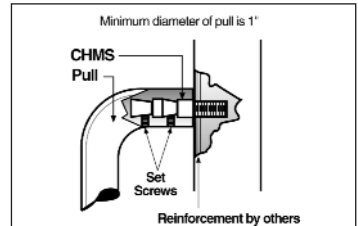

Type	Bolt Size	Drill Size - Metal
17	1/4 - 20	1/4 - 20 tap
17HD	5/16 - 18	5/16 - 18 tap

COMMON END DETAILS

Wood or Metal Door - Type 5

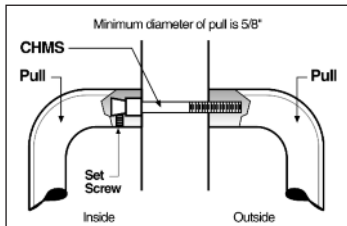

Type	Bolt Size	Drill Size	
		Wood	Metal
5	1/4 - 20	9/32	9/32
5HD	5/16 - 18	11/32	11/32

Glass Door - Type 13

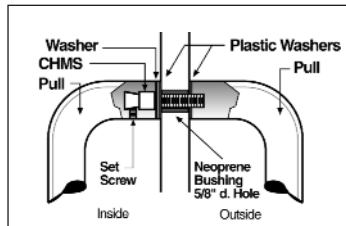

Type	Bolt Size	Drill Size - Glass
13	1/4 - 20	5/8
13HD	5/16 - 18	5/8

NOTE: Heavy Duty (HD/XHD) mounting features hex drive for positive tightening and large overall size for superior strength. Recommended for high frequency and rough service openings.

**Series 47 Push Bar
No. SP47**



Material: Aluminum, Brass, Bronze, Stainless Steel

Finishes: Available in standard architectural finishes; US32DMS, US32D316, US32316, white (WPC), red (RPC), and black (BPC) powder coat finishes (see page 7).

Mounting: Metal & Wood Door: Type 1, 1/4-20 x 2 1/4 Thru Bolt & Finish Washer (standard 1 3/4" door). (**NOTE:** See page A10 for detailed mounting drawings.)

Ordering: Specify CTC, handing, door type, and finish.

Options:

- Engraving "PUSH" or "PULL".
- Advise if door thickness is other than 1 3/4".

No.	CTC	Material Size	Base	Projection	Clearance	Weight	ANSI 156.6
SP47	specify	1" dia.	1" dia.	2 1/2"	1 1/2"	8.5 lbs.	J501

**Series 47 Push Bar
No. 47, 47-2, 47-3, 48**



No. 47

Material: Aluminum, Brass, Bronze, Stainless Steel

Finishes: Available in standard architectural finishes, US32DMS, US32D316, US32316, US3LIFETIME, white (WPC), red (RPC), and black (BPC) powder coat finishes (see page 7).

Mounting: No. 47, 47-2, 47-3
Metal & Wood Door: Type 1, 1/4-20 x 2 1/4 Thru Bolt & Finish Washer (standard 1 3/4" door).
Metal Door: Type 6, Concealed, 1/4-20 CHMS



No. 47-2

No. 48 (not shown)
Metal & Wood Door: Type 1, 1/4-20 x 2 1/4 Thru Bolt & Finish Washer (standard 1 3/4" door).

(**NOTE:** See page A10 for detailed mounting drawings.)

Ordering: Specify CTC, door type, mounting, and finish.

Options:

- Engraving "PUSH" or "PULL".
- Heavy duty versions of most fastening types available — use suffix HD to fastening type number (47 Type 6HD).
- Advise if door thickness is other than 1 3/4".



No. 47-3



Engraved

No.	CTC	Material Size	Base	Projection	Clearance	Weight	ANSI 156.6
47	specify	1" dia.	1" dia.	2 1/2"	1 1/2"	8.5 lbs.	J501
47-2	specify	1" dia.	1" dia.	2 1/2"	1 1/2"	17.0 lbs.	J501
47-3	specify	1" dia.	1" dia.	2 1/2"	1 1/2"	25.5 lbs.	J501
48	specify	3/4" dia.	3/4" dia.	2 1/4"	1 1/2"	4.5 lbs.	J501

Series 47 Push Bars

**Series 47 Push Bar
 No. BP47, BP47-2, BP47-3**



No. BP47



No. BP47-2

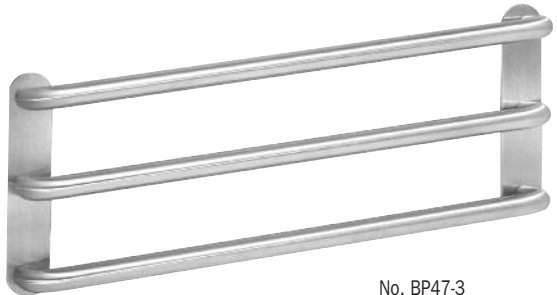

No. BP47-3

Material: Aluminum, Brass, Bronze, Stainless Steel

Finishes: Available in standard architectural finishes, US32DMS, US32D316, US32316, white (WPC), red (RPC), and black (BPC) powder coat finishes (see page 7).

Mounting: No. BP47
 Metal & Wood Door: Type 1, 1/4-20 x 2 1/4 Thru Bolt & Finish Washer (standard 1 3/4" door).

Metal Door: Type 6, Concealed, 1/4-20 CHMS x 1/2 Thread

No. BP47-2, BP47-3
 Metal & Wood Door: Type 1, 1/4-20 x 2 1/4 Thru Bolt & Finish Washer (standard 1 3/4" door).

Metal Door: Type 2, Surface, 8-32 x 3/4 OHMS
 Wood Door: Type 2, Surface, #8 x 3/4 OHSMS

Metal Door: Type 6, Concealed, 1/4-20 CHMS x 1/2" Thread

(NOTE: See page A10 for detailed mounting drawings.)

Ordering: Specify CTC, door type, mounting, and finish.

- Options:**
- Engraving "PUSH" or "PULL".
 - Heavy duty versions of most fastening types available — use suffix HD to fastening type number (BP47 Type 6HD).
 - Advise if door thickness is other than 1 3/4".

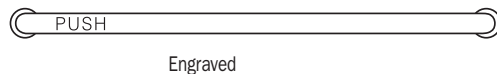

No.	CTC	Material Size	Base	Projection	Clearance	Weight	ANSI 156.6
BP47	specify	1" dia.	1 1/4" dia.	2 5/8"	1 5/8"	9.0 lbs.	J501
BP47-2	specify	1" dia.	2" x 6"	2 5/8"	1 5/8"	18.0 lbs.	J501
BP47-3	specify	1" dia.	2" x 10"	2 5/8"	1 5/8"	27.5 lbs.	J501

Series 47 Straight Push & Pull Bars



Series 47 Straight Single Bar Sets

Material: Aluminum, Brass, Bronze, Stainless Steel

Finishes: Available in standard architectural finishes, US32DMS, US32D**316**, US32**316**, white (WPC), red (RPC), and black (BPC) powder coat finishes (see page 7).
*US**LIFETIME** available on select product below.

Mounting:	Pull	Push	Common		Mounting
Door	Free End	Free End	End	Description	Spec. No.
Metal & Wood	1	1	5	Back to Back & Thru Bolt	T3**
Metal	6	6	5	Back to Back & Concealed	T4
Wood	8	8	5	Back to Back & Concealed	T5
Metal & Wood	12	12	5	Back to Back & Decorative Bolt	T1
Glass	15	15	13	Back to Back & Thru Bolt	T2

** T3 is the standard mounting method for Metal and Wood Doors.
NOTE: See page A10 for detailed mounting drawings.

Ordering: Specify product number, mounting, door type, push bar CTC, and finish (i.e., 11247 T3, wood door, 33" CTC, US32D**316**).

Other: See page A1 on "How To" size push bars.

- Options:**
- Engraving "PUSH" or "PULL" (specify handing).
 - Base plates available similar to those shown on page A12 — use BP prefix (BP11047) when ordering.
 - Heavy duty versions of most fastening types available — use suffix HD to fastening type number (11047 T3HD).



No.	Material Size	Pull			Push		Weight	ANSI 156.6
		CTC	Projection	Clearance	Projection	Clearance		
11047	1" dia.	8"	3"	2"	2½"	1½"	11.5 lbs.	J504
111A47	1" dia.	9"	3"	2"	2½"	1½"	11.7 lbs.	J504
11147*	1" dia.	10"	3"	2"	2½"	1½"	12.0 lbs.	J504
11247*	1" dia.	12"	3"	2"	2½"	1½"	12.5 lbs.	J504
11847	1" dia.	18"	3"	2"	2½"	1½"	14.0 lbs.	J504

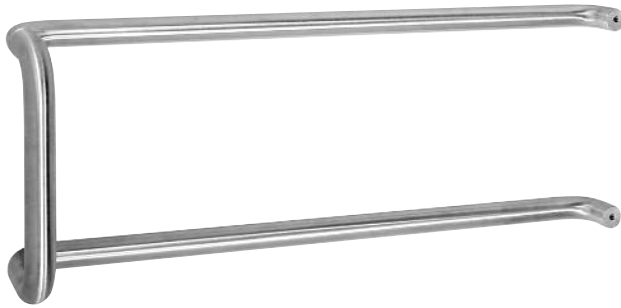

Series 47 Straight Double Bar Sets

Material: Aluminum, Brass, Bronze, Stainless Steel

Finishes: Available in standard architectural finishes, US32DMS, US32D**316**, US32**316**, white (WPC), red (RPC), and black (BPC) powder coat finishes (see page 7).
 *US3**LIFETIME** available on select product below.

Mounting:	Push	Common		Mounting
Door	Free End	End	Description	Spec. No.
Metal & Wood	1	5	Back to Back & Thru Bolt	T3**
Metal	6	5	Back to Back & Concealed	T4
Wood	8	5	Back to Back & Concealed	T5
Metal & Wood	12	5	Back to Back & Decorative Bolt	T1
Glass	15	13	Back to Back & Thru Bolt	T2

** T3 is the standard mounting method for Metal and Wood Doors.

NOTE: See page A10 for detailed mounting drawings.

Ordering: Specify product number, mounting, door type, push bar CTC, and finish (i.e., 11247-2 T3, wood door, 33" CTC, US32D**316**).

Other: See page A1 on "How To" size push bars.

- Options:**
- Engraving "PUSH" or "PULL" (specify handing).
 - Base plates available similar to those shown on page A12 — use BP prefix (BP11047-2) when ordering.
 - Heavy duty versions of most fastening types available — use suffix HD to fastening type number (11047-2 T3HD).

No.	Material Size	Pull			Push		Weight	ANSI 156.6
		CTC	Projection	Clearance	Projection	Clearance		
11047-2	1" dia.	8"	3"	2"	2½"	1½"	20.0 lbs.	J504
111A47-2	1" dia.	9"	3"	2"	2½"	1½"	20.2 lbs.	J504
11147-2*	1" dia.	10"	3"	2"	2½"	1½"	20.5 lbs.	J504
11247-2*	1" dia.	12"	3"	2"	2½"	1½"	21.0 lbs.	J504

Series 47 Straight Push & Pull Bars

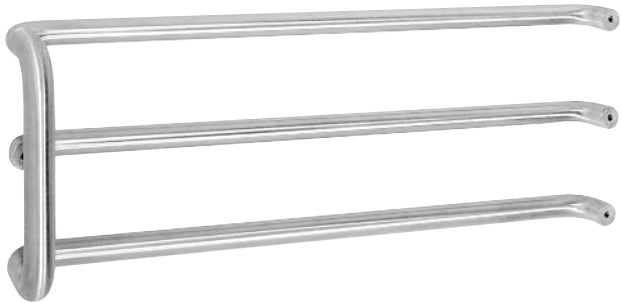

Series 47 Straight Triple Bar Sets

Material: Aluminum, Brass, Bronze, Stainless Steel

Finishes: Available in standard architectural finishes, US32D**MS**, US32D**316**, US32**316**, white (WPC), red (RPC), and black (BPC) powder coat finishes (see page 7).
 *US3**LIFETIME** available on select product below.

Mounting:	Door	Push	Common	Description	Mounting Spec. No.
		Free End	End		
	Metal & Wood	1	5	Back to Back & Thru Bolt	T3**
	Metal	6	5	Back to Back & Concealed	T4
	Wood	8	5	Back to Back & Concealed	T5
	Metal & Wood	12	5	Back to Back & Decorative Bolt	T1
	Glass	15	13	Back to Back & Thru Bolt	T2

** T3 is the standard mounting method for Metal and Wood Doors.

NOTE: See page A10 for detailed mounting drawings.

Ordering: Specify product number, mounting, door type, push bar CTC, and finish (i.e., 11247-3 T3, wood door, 33" CTC, US32D**316**).

Other: See page A1 on "How To" size push bars.

- Options:**
- Engraving "PUSH" or "PULL" (specify handing).
 - Base plates available similar to those shown on page A12 — use BP prefix (BP11047-3) when ordering.
 - Heavy duty versions of most fastening types available — use suffix HD to fastening type number (11047-3 T3HD).

No.	Material Size	Pull			Push		Weight	ANSI 156.6
		CTC	Projection	Clearance	Projection	Clearance		
11047-3	1" dia.	8"	3"	2"	2½"	1½"	28.5 lbs.	J504
111A47-3	1" dia.	9"	3"	2"	2½"	1½"	28.7 lbs.	J504
11147-3*	1" dia.	10"	3"	2"	2½"	1½"	29.0 lbs.	J504
11247-3*	1" dia.	12"	3"	2"	2½"	1½"	29.5 lbs.	J504



Series 47 Offset Single Bar Sets

Material: Aluminum, Brass, Bronze, Stainless Steel

Finishes: Available in standard architectural finishes, US32D**MS**, US32D**316**, US32**316**, white (WPC), red (RPC), and black (BPC) powder coat finishes (see page 7).
 *US3**LIFETIME** available on select product below.

Mounting: Door	Pull	Push	Common	Description	Mounting Spec. No.
	Free End	Free End	End		
Metal & Wood	1	1	5	Back to Back & Thru Bolt	T3**
Metal	17	6	16	Back to Back & Concealed	T4
Wood	8	8	5	Back to Back & Concealed	T5
Metal & Wood	12	12	5	Back to Back & Decorative Bolt	T1
Glass	15	15	13	Back to Back & Thru Bolt	T2

** T3 is the standard mounting method for Metal and Wood Doors.

NOTE: See page A10 for detailed mounting drawings.

Ordering: Specify product number, mounting, door type, push bar CTC, and finish (i.e., BF15747 T3, wood door, 33" CTC, US32D**316**).

Other: See page A1 on "How To" size push bars.

- Options:**
- Engraving "PUSH" or "PULL" (specify handing).
 - Base plates available similar to those shown on page A12 — use BP prefix (BPBF15747) when ordering.
 - Heavy duty versions of most fastening types available — use suffix HD to fastening type number (BF15647 T3HD).

No.	Material Size	Pull			Push		Weight	ANSI 156.6
		CTC	Projection	Clearance	Projection	Clearance		
BF15647	1" dia.	8"	3½"	2½"	2½"	1½"	12.4 lbs.	J505
BF157A47	1" dia.	9"	3½"	2½"	2½"	1½"	12.6 lbs.	J505
BF15747*	1" dia.	10"	3½"	2½"	2½"	1½"	12.8 lbs.	J505
BF15847	1" dia.	12"	3½"	2½"	2½"	1½"	13.3 lbs.	J505
BF15947	1" dia.	18"	3½"	2½"	2½"	1½"	15.0 lbs.	J505

Series 47 Offset Push & Pull Bars

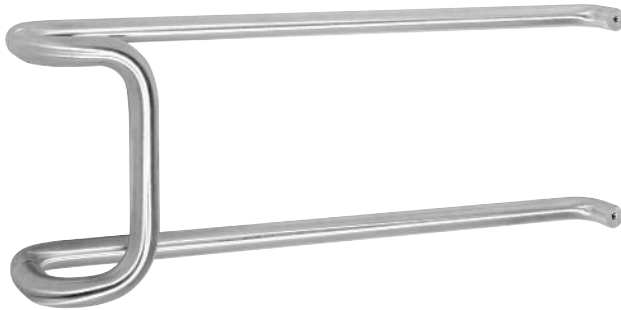

Series 47 Offset Double Bar Sets

Material: Aluminum, Brass, Bronze, Stainless Steel

Finishes: Available in standard architectural finishes, US32D**MS**, US32D**316**, US32**316**, white (WPC), red (RPC), and black (BPC) powder coat finishes (see page 7).
 *US3**LIFETIME** available on select product below.

Mounting:	Push		Common	Description	Mounting Spec. No.
	Door	Free End			
Metal & Wood	1	5	5	Back to Back & Thru Bolt	T3**
Metal	6	6	16	Back to Back & Concealed	T4
Wood	8	8	5	Back to Back & Concealed	T5
Metal & Wood	12	12	5	Back to Back & Decorative Bolt	T1
Glass	15	15	13	Back to Back & Thru Bolt	T2

** T3 is the standard mounting method for Metal and Wood Doors.

NOTE: See page A10 for detailed mounting drawings.

Ordering: Specify product number, mounting, door type, push bar CTC, and finish (i.e., BF15747-2 T3, wood door, 33" CTC, US32D**316**).

Other: See page A1 on "How To" size push bars.

- Options:**
- Engraving "PUSH" or "PULL" (specify handing).
 - Base plates available similar to those shown on page A12 — use BP prefix (BPBF15747-2) when ordering.
 - Heavy duty versions of most fastening types available — use suffix HD to fastening type number (BF15647-2 T3HD).

No.	Material Size	Pull			Push		Weight	ANSI 156.6
		CTC	Projection	Clearance	Projection	Clearance		
BF15647-2	1" dia.	8"	3½"	2½"	2½"	1½"	20.9 lbs.	J505
BF157A47-2	1" dia.	9"	3½"	2½"	2½"	1½"	21.1 lbs.	J505
BF15747-2*	1" dia.	10"	3½"	2½"	2½"	1½"	21.3 lbs.	J505
BF15847-2	1" dia.	12"	3½"	2½"	2½"	1½"	21.8 lbs.	J505

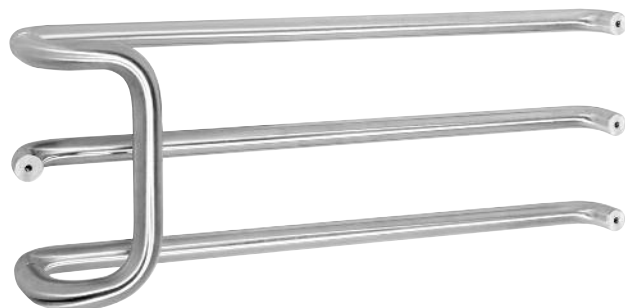

Series 47 Offset Triple Bar Sets

Material: Aluminum, Brass, Bronze, Stainless Steel

Finishes: Available in standard architectural finishes, US32D**MS**, US32D**316**, US32**316**, white (WPC), red (RPC), and black (BPC) powder coat finishes (see page 7).

*US3**LIFETIME** available on select product below.

Mounting: Door	Push	Common	Description	Mounting Spec. No.
	Free End	End		
Metal & Wood	1	5	Back to Back & Thru Bolt	T3**
Metal	6	16	Back to Back & Concealed	T4
Wood	8	5	Back to Back & Concealed	T5
Metal & Wood	12	5	Back to Back & Decorative Bolt	T1
Glass	15	13	Back to Back & Thru Bolt	T2

** T3 is the standard mounting method for Metal and Wood Doors.

NOTE: See page A10 for detailed mounting drawings.

Ordering: Specify product number, mounting, door type, push bar CTC, and finish (i.e., BF15747-3 T3, wood door, 33" CTC, US32D**316**).

Other: See page A1 on "How To" size push bars.

- Options:**
- Engraving "PUSH" or "PULL" (specify handing).
 - Base plates available similar to those shown on page A12 — use BP prefix (BPBF15747-3) when ordering.
 - Heavy duty versions of most fastening types available — use suffix HD to fastening type number (BF15647-3 T3HD).

No.	Material Size	Pull			Push		Weight	ANSI 156.6
		CTC	Projection	Clearance	Projection	Clearance		
BF15647-3	1" dia.	8"	3½"	2½"	2½"	1½"	29.4 lbs.	J505
BF157A47-3	1" dia.	9"	3½"	2½"	2½"	1½"	29.6 lbs.	J505
BF15747-3*	1" dia.	10"	3½"	2½"	2½"	1½"	29.8 lbs.	J505
BF15847-3	1" dia.	12"	3½"	2½"	2½"	1½"	30.3 lbs.	J505

T Series 1" Tubular Push Bars and Push & Pull Bar Sets

Rockwood's new T Series 1" diameter tubular push bars and pull bar sets are made from sturdy .065" thick wall tubing. Solid brass or stainless steel inserts are brazed into the ends to provide a solid area for our guaranteed mounting systems.

Benefits of specifying the T Series push and pulls include:

- Tubular pulls weigh 25% of their solid counterparts; this 75% weight reduction greatly reduces the environmental impact of harvesting material for their manufacture – a LEED certified building goal.
- The lighter weight minimizes the risk of damage in shipping and handling.
- The cost of most tubular pulls represents a significant savings over the equivalent solid model.

Considering all the benefits, the T Series pulls offer an improved value without any quality sacrifice.

T Series is also available in Straight pulls (see page B15) and Offset pulls (see page B29).

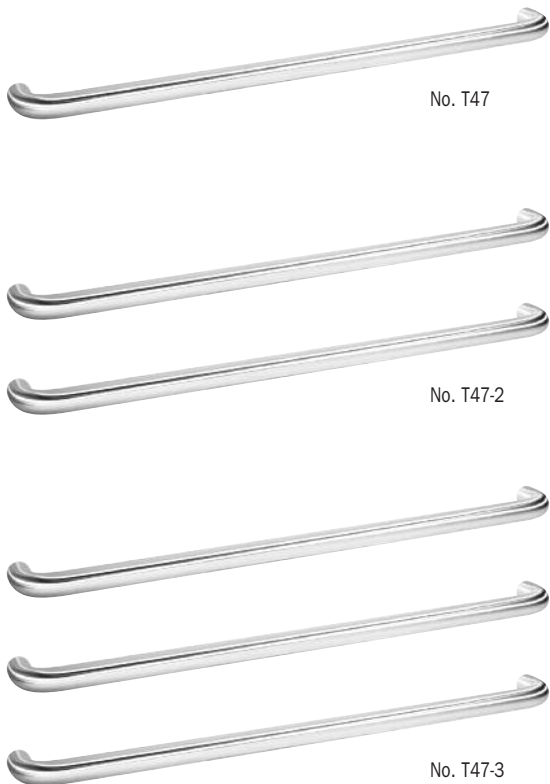

**T47 Series Tubular Push Bars
No. T47, T47-2, T47-3**

Material: Brass, Bronze, Stainless Steel

Finishes: Available in standard architectural finishes (see page 7).

Mounting: Metal & Wood Door: Type 1, ¼-20 x 2¼ Thru Bolt & Finish Washer (standard 1¾" door).

Metal Door: Type 6, Concealed, ¼-20 CHMS

NOTE: See page A10 for detailed mounting drawings.

Ordering: Specify CTC, door type, mounting, and finish.

Options:

- Engraving "PUSH" or "PULL".
- Advise if door thickness is other than 1¾".

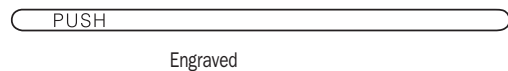

No.	CTC	Material Size	Base	Projection	Clearance	Weight	ANSI 156.6
T47	specify	1" dia.	1" dia.	2½"	1½"	2.9 lbs.	J501
T47-2	specify	1" dia.	1" dia.	2½"	1½"	5.8 lbs.	J501
T47-3	specify	1" dia.	1" dia.	2½"	1½"	8.7 lbs.	J501

Series 47 Straight Tubular Push & Pull Bars



T47 Series Straight Tubular Single Bar Sets

Material: Brass, Bronze, Stainless Steel

Finishes: Available in standard architectural finishes (see page 7).

Mounting:	Door	Pull	Push	Common	Description	Mounting Spec. No.
		Free End	Free End	End		
	Metal & Wood	1	1	5	Back to Back & Thru Bolt	T3*
	Metal	6	6	5	Back to Back & Concealed	T4
	Wood	8	8	5	Back to Back & Concealed	T5
	Metal & Wood	12	12	5	Back to Back & Decorative Bolt	T1
	Glass	15	15	13	Back to Back & Thru Bolt	T2

*T3 is the standard mounting method for Metal and Wood Doors.

NOTE: See page A10 for detailed mounting drawings.

Ordering: Specify product number, mounting, door type, push bar CTC, and finish (i.e., T11247 T3, wood door, 33" CTC, US32D).

Other: See page A1 on "How To" size push bars.

Options:

- Engraving "PUSH" or "PULL" (specify handing).
- Base plates available similar to those shown on page A12 — use BP prefix (TBP11047) when ordering.



No.	Material Size	Pull			Push		Weight	ANSI 156.6
		CTC	Projection	Clearance	Projection	Clearance		
T11047	1" dia.	8"	3"	2"	2½"	1½"	3.9 lbs.	J504
T111A47	1" dia.	9"	3"	2"	2½"	1½"	4.0 lbs.	J504
T11147	1" dia.	10"	3"	2"	2½"	1½"	4.0 lbs.	J504
T11247	1" dia.	12"	3"	2"	2½"	1½"	4.1 lbs.	J504
T11847	1" dia.	18"	3"	2"	2½"	1½"	4.6 lbs.	J504

Series 47 Offset Tubular Push & Pull Bars



TBF47 Series Offset Tubular Single Bar Sets

Material: Brass, Bronze, Stainless Steel

Finishes: Available in standard architectural finishes (see page 7).

Mounting: Door	Pull	Push	Common	Description	Mounting Spec. No.
	Free End	Free End	End		
Metal & Wood	1	1	5	Back to Back & Thru Bolt	T3*
Metal	17	6	16	Back to Back & Concealed	T4
Wood	8	8	5	Back to Back & Concealed	T5
Metal & Wood	12	12	5	Back to Back & Decorative Bolt	T1
Glass	15	15	13	Back to Back & Thru Bolt	T2

*T3 is the standard mounting method for Metal and Wood Doors.

NOTE: See page A10 for detailed mounting drawings.

Ordering: Specify product number, mounting, door type, push bar CTC, and finish (i.e., TBF15747 T3, wood door, 33" CTC, US32D).

Other: See page A1 on "How To" size push bars.

Options:

- Engraving "PUSH" or "PULL" (specify handing).
- Base plates available similar to those shown on page A12 — use BP prefix (TBPBF15747) when ordering.

No.	Material Size	Pull			Push		Weight	ANSI 156.6
		CTC	Projection	Clearance	Projection	Clearance		
TBF15647	1" dia.	8"	3½"	2½"	2½"	1½"	4.2 lbs.	J504
TBF157A47	1" dia.	9"	3½"	2½"	2½"	1½"	4.3 lbs.	J504
TBF15747	1" dia.	10"	3½"	2½"	2½"	1½"	4.3 lbs.	J504
TBF15847	1" dia.	12"	3½"	2½"	2½"	1½"	4.4 lbs.	J504
TBF15947	1" dia.	18"	3½"	2½"	2½"	1½"	4.9 lbs.	J504

ROCKWOOD

ASSA ABLOY



**B - Push Plates, Pulls and Pull Plates
from Rockwood**

Strength and Style

Guaranteed Mounting Systems

Beautiful Finishes

Matching Stainless Steel Fasteners

ASSA ABLOY, the global leader
in door opening solutions

Location Standards

Positioning Applications:

- door pulls to plates
- cutouts on plates
- engraving on plates
- cutout and engraving on plates

NOTE: Be sure the pull you choose will fit on the plate, allowing for cutouts and/or engraving.

Sizing:

- 1 1/4" standard cylinder hole cutout size
- 3/8" diameter standard turn knob hole
- other cutout sizes and styles are readily available

Engraving:

- 3/4" high condensed block letters with black enamel fill
- other letter sizes and styles are readily available

ADA Accessibility Guidelines for Buildings and Facilities (ADAAG)

As amended through January 1998

4.13.9 **Door Hardware.** Handles, pulls, latches, locks, and other operating devices on accessible doors shall have a shape that is easy to grasp with one hand and does not require tight grasping, tight pinching, or twisting of the wrist to operate. Lever-operated mechanisms, push-type mechanisms, and U-shaped handles are acceptable designs. When sliding doors are fully open, operating hardware shall be exposed and usable from both sides. Hardware required for accessible door passage shall be mounted no higher than 48 in. (1220 mm) above finished floor.

Pull Positioning On Plates 4" Or Less In Width

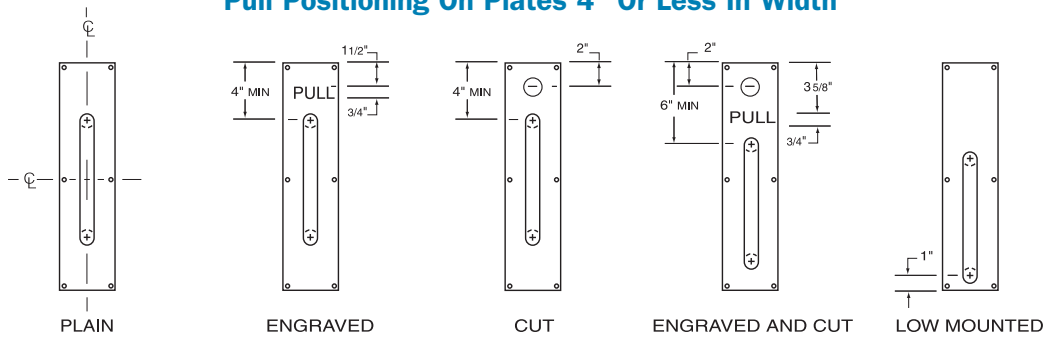

Pull Positioning On Plates Wider Than 4" (Handing Required)

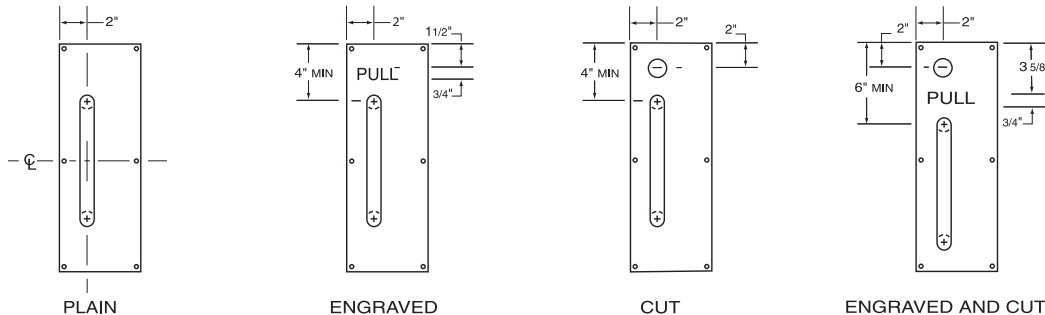

Recommended Locations On Door

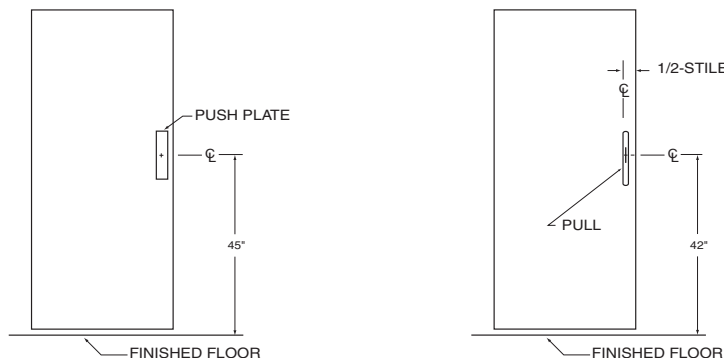

Push Plates - .050" Thick

Material: Aluminum, Brass, Bronze, Stainless Steel

Finishes: Available in standard architectural finishes, US32DMS, US32D316, US32316, and US3LIFETIME (see page 7).

Fastener: #6 x 5/8 OH SMS

Features: Four beveled edges.

Ordering: Specify plate number followed by size designation and finish; i.e., 70B US32D or for non-standard size 70 (width x height) and finish. Specify any additional optional features.

- Options:**
- Custom sizes available upon request.
 - TEK - self-drilling screws.
 - TORX - security torx screws.
 - SA - self-adhesive mounting: 1/16" double face foam tape (no screw holes on plate).
 - Engraving on plates 4" wide or wider. Specify copy. See page B1 for standard engraving locations.
 - Cylinder Cutouts (CFC) and Turn Knob Cutouts (CFTT). See page B1 for standard locations and sizes.



No. 70

No.	Standard Size	Weight	ANSI A156.6
70A	3" x 12"	0.7 lbs.	J301
70B	3½" x 15"	0.9 lbs.	J301
70C	4" x 16"	1.0 lbs.	J301
70E	6" x 16"	1.5 lbs.	J301
70F	8" x 16"	2.0 lbs.	J301
70G	4" x 20"	1.3 lbs.	J301



No. 70RC

No.	Standard Size	Weight	ANSI A156.6
70RCA	3" x 12"	0.7 lbs.	J301
70RCB	3½" x 15"	0.9 lbs.	J301
70RCC	4" x 16"	1.0 lbs.	J301
70RCE	6" x 16"	1.5 lbs.	J301
70RCF	8" x 16"	2.0 lbs.	J301
70RCG	4" x 20"	1.3 lbs.	J301



No. 70RE

No.	Standard Size	Weight	ANSI A156.6
70REA	3" x 12"	0.7 lbs.	J301
70REB	3½" x 15"	0.9 lbs.	J301
70REC	4" x 16"	1.0 lbs.	J301

Push Plates - .062" Thick

Material: Aluminum, Brass, Bronze, Stainless Steel

Finishes: Available in standard architectural finishes (see page 7).

Fastener: #6 x 5/8 OH SMS

Features: Four beveled edges.

Ordering: Specify plate number followed by size designation and finish; i.e., 71B US32D or for non-standard size 71 (width x height) and finish. Specify any additional optional features.

- Options:**
- Custom sizes available upon request.
 - TEK - self-drilling screws.
 - TORX - security torx screws.
 - SA - self-adhesive mounting: 1/16" double face foam tape (no screw holes on plate).
 - Engraving on plates 4" wide or wider. Specify copy. See page B1 for standard engraving locations.
 - Cylinder Cutouts (CFC) and Turn Knob Cutouts (CFTT). See page B1 for standard locations and sizes.



No. 71

No.	Standard Size	Weight	ANSI A156.6
71A	3" x 12"	0.9 lbs.	J301
71B	3½" x 15"	1.1 lbs.	J301
71C	4" x 16"	1.2 lbs.	J301
71E	6" x 16"	1.8 lbs.	J301
71F	8" x 16"	2.4 lbs.	J301
71G	4" x 20"	1.5 lbs.	J301



No. 71RC

No.	Standard Size	Weight	ANSI A156.6
71RCA	3" x 12"	0.9 lbs.	J301
71RCB	3½" x 15"	1.1 lbs.	J301
71RCC	4" x 16"	1.2 lbs.	J301
71RCE	6" x 16"	1.8 lbs.	J301
71RCF	8" x 16"	2.4 lbs.	J301
71RCG	4" x 20"	1.5 lbs.	J301



No. 71RE

No.	Standard Size	Weight	ANSI A156.6
71REA	3" x 12"	0.9 lbs.	J301
71REB	3½" x 15"	1.1 lbs.	J301
71REC	4" x 16"	1.2 lbs.	J301

Push Plates - .125" Thick

Material: Aluminum, Brass, Bronze, Stainless Steel

Finishes: Available in standard architectural finishes, US32D**316**, and US32**316** (see page 7).

Fastener: #6 x 5/8 OH SMS

Features: Four beveled edges.

Ordering: Specify plate number followed by size designation and finish; i.e., 73B US32D or for non-standard size 73 (width x height) and finish. Specify any additional optional features.

- Options:**
- Custom sizes available upon request.
 - TEK - self-drilling screws.
 - TORX - security torx screws.
 - SA - self-adhesive mounting: 1/16" double face foam tape (no screw holes on plate).
 - Engraving on plates 4" wide or wider. Specify copy. See page B1 for standard engraving locations.
 - Cylinder Cutouts (CFC) and Turn Knob Cutouts (CFTT). See page B1 for standard locations and sizes.



No. 73

No.	Standard Size	Weight	ANSI A156.6
73A	3" x 12"	1.7 lbs.	J304
73B	3½" x 15"	2.1 lbs.	J304
73C	4" x 16"	2.5 lbs.	J304
73E	6" x 16"	3.8 lbs.	J304
73F	8" x 16"	5.0 lbs.	J304
73G	4" x 20"	3.2 lbs.	J304



No. 73RC

No.	Standard Size	Weight	ANSI A156.6
73RCA	3" x 12"	1.7 lbs.	J304
73RCB	3½" x 15"	2.1 lbs.	J304
73RCC	4" x 16"	2.5 lbs.	J304
73RCE	6" x 16"	3.8 lbs.	J304
73RCF	8" x 16"	5.0 lbs.	J304
73RCG	4" x 20"	3.2 lbs.	J304



No. 73RE

No.	Standard Size	Weight	ANSI A156.6
73REA	3" x 12"	1.7 lbs.	J304
73REB	3½" x 15"	2.1 lbs.	J304
73REC	4" x 16"	2.5 lbs.	J304

**Push Plates - .188" Thick
No. 74**



- Material:** Aluminum, Bronze, Stainless Steel
- Finishes:** Available in standard architectural finishes (see page 7).
- Fastener:** #6 x 5/8 OH SMS
- Features:** Four beveled edges.
- Ordering:** Specify finish and any other optional features.
- Options:**
- Custom sizes available upon request.
 - Engraving on plates 4" wide or wider. Specify copy. See page B1 for standard engraving locations.
 - Cylinder Cutouts (CFC) and Turn Knob Cutouts (CFTT). See page B1 for standard locations and sizes.

No.	Standard Size	Weight	ANSI A156.6
74B	3½" x 15"	3.2 lbs.	J304
74C	4" x 16"	3.8 lbs.	J304

**Push Plates - .125" Thick
No. 75**



- Material:** Plastic Laminate, Clear Plastic, Kydex®
- Colors:** Black, Brown, Gray, Beige, White, and Clear
- Fastener:** #6 x 5/8 OH SMS
- Features:** Four beveled edges.
- Ordering:** Specify color and any other optional features.
- Options:**
- Custom sizes available upon request.
 - SA - Self-adhesive mounting: 1/16" double face foam tape (no screw holes on plate). Not available on Clear Plastic.
 - Engraving on plates 4" wide or wider. Specify copy. See page B1 for standard engraving locations.
 - Cylinder Cutouts (CFC) and Turn Knob Cutouts (CFTT). See page B1 for standard locations and sizes.

No.	Standard Size	Weight	ANSI
75A	3" x 12"	0.3 lbs.	J304
75B	3½" x 15"	0.4 lbs.	J304
75C	4" x 16"	0.5 lbs.	J304
75E	6" x 16"	0.7 lbs.	J304
75F	8" x 16"	0.9 lbs.	J304
75G	4" x 20"	0.6 lbs.	J304

© Kydex is a registered trademark of Kleerdex Company.

**Decorative Push Plates - .050" Thick
No. 76, 77**

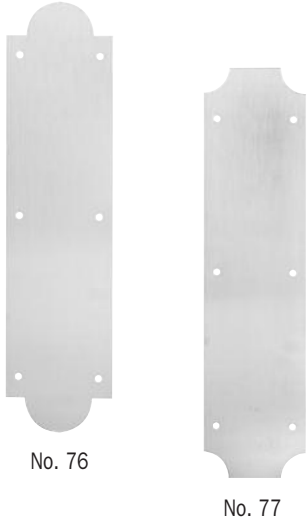

Material: Brass, Bronze
Finishes: Available in standard architectural finishes, and US3**LIFETIME** (see page 7).
Fastener: #6 x 5/8 OH SMS
Ordering: Specify finish.
Options: These plates look great when combined with the No. 147 or 148 pulls as shown on page B26.

No.	Standard Size	Weight	ANSI
76B	3½" x 15"	0.9 lbs.	J301
76C	4" x 16"	1.0 lbs.	J301
77B	3½" x 15"	0.9 lbs.	J301
77C	4" x 16"	1.0 lbs.	J301

**Push Plates - .050" Thick
No. 80, 81, 82**

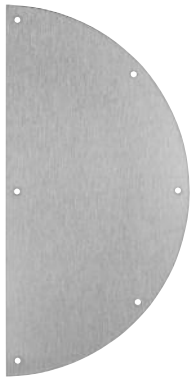

Material: Aluminum, Brass, Bronze, Stainless Steel
Finishes: Available in standard architectural finishes, US32**DMS**, US32D**316**, and US32**316** (see page 7).
Fastener: #6 x 5/8 OH SMS
Ordering: Specify finish.
Options:

- Plates may be mated with most any door pull of your choice.
- Custom sizes available upon request.

No.	Standard Size	Weight	ANSI
80	6" x 12"	1.4 lbs.	J301
81	7½" x 15"	1.6 lbs.	J301
82	8" x 16"	1.8 lbs.	J301

**Push Plate - .050" Thick
No. 84**

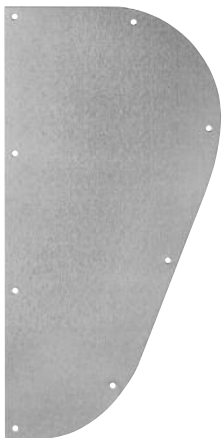

Material: Aluminum, Brass, Bronze, Stainless Steel
Finishes: Available in standard architectural finishes, US32**DMS**, US32D**316**, and US32**316** (see page 7).
Fastener: #6 x 5/8 OH SMS
Ordering: Specify finish and handing (right handing shown).
Options:

- Variations of design can be created to fit your requests.
- Plate may be mated with most any door pull of your choice.

No.	Standard Size	Weight	ANSI
84	10" x 20"	2.1 lbs.	J301

**Push Plates - .050" Thick
No. 85, 86**



- Material:** Aluminum, Brass, Bronze, Stainless Steel
- Finishes:** Available in standard architectural finishes, and US32DMS (see page 7).
- Fastener:** #6 x 5/8 OH SMS
- Features:** Cold forged to 7/32" thick.
- Ordering:** Specify finish.
- Options:** Plates may be mated with most any door pull of your choice.

No.	Standard Size	Weight	ANSI
85	3½" x 15"	0.9 lbs.	J302
86	4" x 16"	1.0 lbs.	J302

**Push Plate - .125" Thick
No. 87**



- Material:** Aluminum, Brass, Bronze, Stainless Steel
- Finishes:** Available in standard architectural finishes (see page 7).
- Fastener:** #6 x 5/8 OH SMS
- Ordering:** Specify finish.
- Options:**
- Variations of design can be created to fit your requests.
 - Plate may be mated with most any door pull of your choice.

No.	Standard Size	Weight	ANSI
87	2½" x 16"	2.0 lbs.	J304

**Heavy Duty Security Flush Pull
No. D89**



Material: Cast Brass
Finishes: Available in US4 and US26D (see page 7).
Fastener: ¼-20 x ½ OH Security Torx MS

No.	Size	Grip Opening	Depth	Weight	ANSI A156.6
D89	4" x 5"	1¼" x 3¼"	7/8"	1.3 lbs.	J403

**Cylinder Pulls
No. 90, 90B**



Material: .125" Aluminum, Brass, Bronze, Stainless Steel
Finishes: Available in standard architectural finishes, and US32DMS (see page 7).
Fastener: Cylinder ring and self-adhesive mounting.
Options: No cylinder hole — screw mounted, order No. 90B.

No.	Size	Opening	Projection	Weight	ANSI A156.6
90	2" x 3¾"	1¼" dia.	1"	0.3 lbs.	J303
90B	2" x 3¾"	—	1"	0.3 lbs.	J303

**Combination Push Pull Plates
No. 91, 92, 93**



Material: .125" Aluminum, Brass, Bronze, Stainless Steel
Finishes: Available in standard architectural finishes, and US32DMS (see page 7).
Fastener: #8 x 7/8 SMS
Options:

- TORX - security torx screws.
- Cylinder Cutouts (CFC) and Turn Knob Cutouts (CFTT). See page B1 for standard locations and sizes.

No.	Size	Projection	Weight	ANSI A156.6
91	3½" x 15¾"	1"	1.9 lbs.	J303
92	4" x 15¾"	1"	2.2 lbs.	J303
93	8" x 15¾"	1"	4.4 lbs.	J303

**Flush Pulls
No. 94, 94BTB**



Material: .125" Brass, Bronze, Stainless Steel
Finishes: Available in standard architectural finishes, US32DMS, US32D316, and US32316 (see page 7).
NOTE: Cups are painted black on all finishes except stainless steel.
Fastener: No. 94: #8 x 3/4 SMS
 No. 94BTB: 8-32 x 3/4 OHMS with Sleeves Type 10
Options: TORX - security torx screws.

No.	Size	Grip Opening	Depth	Weight	ANSI A156.6
94	3 1/2" x 5"	1 3/4" x 3 1/8"	7/8"	0.6 lbs.	J403
94BTB (pair)	3 1/2" x 5"	1 3/4" x 3 1/8"	1 3/4"	1.2 lbs.	J403

**Flush Pull
No. 94C**



Material: .125" Brass, Bronze, Stainless Steel
Finishes: Available in standard architectural finishes, US32DMS, US32D316, and US32316 (see page 7).
NOTE: Cups are painted black on all finishes except stainless steel.
Fastener: #6 x 1 TH SMS
Features: Fasteners concealed in cup.

No.	Size	Grip Opening	Depth	Weight	ANSI A156.6
94C	3 1/2" x 5"	1 3/4" x 3 1/8"	7/8"	0.6 lbs.	J403

**Dead Lock Flush Pulls
No. 94DLL, 94DLS**



Material: .125" Brass, Bronze, Stainless Steel
Finishes: Available in standard architectural finishes, US32DMS, US32D316, and US32316 (see page 7).
NOTE: Cups are painted black on all finishes except stainless steel.
Fastener: #8 x 3/4 OH SMS
Options:

- TORX - security torx screws.
- Custom sizes.

Features:

- Used with dead bolt lock. 1 1/4" cylinder hole is standard.
- Vandal resistant.
- Use where projecting trim is an operational problem or an esthetic objection.
- Ideal for use on "exit only" doors where occasional entrance is required (warehouse exits), night latch function exit device openings (classroom exit only doors), mechanical closet doors and anywhere dead locking is approved.

No.	Size	Grip Opening	Depth	Weight	ANSI A156.6
94DLL	6 1/8" x 8"	1 3/4" x 6 1/8"	7/8"	1.0 lbs.	J403
94DLS	6 1/8" x 5"	1 3/4" x 3 1/8"	7/8"	0.8 lbs.	J403

**Flush Pull
No. 94L**



- Material:** .125" Brass, Bronze, Stainless Steel
- Finishes:** Available in standard architectural finishes, US32DMS, US32D316, and US32316 (see page 7). ***NOTE:** Cups are painted black on all finishes except stainless steel.
- Fastener:** ¼-20 x 1½ Thru Bolt & Finish Washer (Standard 1¾" door).
- Options:**
- TORX - security torx screws.
 - Advise if door thickness other than 1¾".
- Features:** Includes lugs for thru bolt. No fasteners on pull side.

No.	Size	Grip Opening	Depth	Weight	ANSI A156.6
94L	3½" x 5"	1¾" x 3⅞"	⅞"	0.6 lbs.	J403

**Flush Pull
No. 94P**



- Material:** .125" Brass, Bronze, Stainless Steel
- Finishes:** Available in standard architectural finishes, US32DMS, US32D316, and US32316 (see page 7). ***NOTE:** Cups are painted black on all finishes except stainless steel.
- Fastener:** ¼-20 x 1½ MS
- Options:** TORX - security torx screws.
- Features:** Usually used with the 94L as a set (see below).

No.	Size	Grip Opening	Depth	Weight	ANSI A156.6
94P	3½" x 5"	1¾" x 3⅞"	⅞"	0.6 lbs.	J403

**Flush Pull Set
No. 94P x 94L**

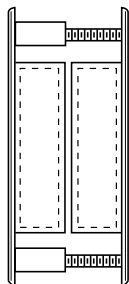

- Material:** .125" Brass, Bronze, Stainless Steel
- Finishes:** Available in standard architectural finishes, US32DMS, US32D316, and US32316 (see page 7). ***NOTE:** Cups are painted black on all finishes except stainless steel.
- Fastener:** ¼-20 x 1½ Thru Bolt (Standard 1¾" door).
- Options:**
- TORX - security torx screws.
 - Advise if door thickness other than 1¾".

No.	Size	Weight	ANSI A156.6
94P x 94L	set consists of 1 #94L and 1 #94P	1.3 lbs.	J403

**Flush Pull
No. 95A**



Material: Cast Brass
Finishes: Available in standard architectural finishes (see page 7).
Fastener: #6 x 5/8 SMS
Features: Fasteners concealed in cup.

No.	Size	Grip Opening	Depth	Weight	ANSI A156.6
95A	2 3/16" x 3 1/4"	7/8" x 2 7/16"	3/4"	0.6 lbs.	J403

**Flush Pull
No. 95B**



Material: Cast Brass
Finishes: Available in standard architectural finishes (see page 7).
Fastener: #8 x 7/8 SMS
Features: Fasteners concealed in cup.

No.	Size	Grip Opening	Depth	Weight	ANSI A156.6
95B	2 11/16" x 4 3/16"	1 7/16" x 3 1/2"	3/4"	0.8 lbs.	J403

**Flush Pull
No. 95R**



Material: Cast Brass
Finishes: Available in standard architectural finishes (see page 7).
Fastener: #8 x 7/8 SMS
Features: Fasteners concealed in cup.

No.	Size	Grip Opening	Depth	Weight	ANSI A156.6
95R	3 1/2" dia.	2 3/4" x 1 11/16"	7/8"	0.6 lbs.	J403

**Flush Pull
No. 96**



Material: .125" Aluminum, Brass, Bronze, Stainless Steel

Finishes: Available in standard architectural finishes (see page 7).

Fastener: #8 x 7/8 SMS

Options:

- TORX - security torx screws.
- Special sizes.
- Cylinder Cutouts (CFC) and Turn Knob Cutouts (CTFF).
See page B1 for standard locations and sizes.

No.	Size	Grip Opening	Depth	Weight	ANSI A156.6
96	4" x 16"	1 3/4" x 3 1/8"	7/8"	2.2 lbs.	J403

**Barrier Free Flush Pulls
No. BF97, BF97L**



No. BF97

Material: .125" Brass, Bronze, Stainless Steel

Finishes: Available in standard architectural finishes, and US32DMS (see page 7).

Fastener: No. BF97: #8 x 7/8 SMS
No. BF97L: 10-24 Stud Welded Lugs and 10-24 Thru Bolts

Options: TORX - security torx screws.

Features: ADA flush pull.



No. BF97L

No.	Size	Grip Opening	Depth	Weight	ANSI A156.6
BF97	5" x 5"	2 1/2" x 3 1/2"	7/8"	1.0 lbs.	J403
BF97L	5" x 5"	2 1/2" x 3 1/2"	7/8"	1.0 lbs.	J403

Straight Door Pulls Mounting Details

NOTE: Heavy Duty (HD/XHD) mounting features hex drive for positive tightening and large overall size for superior strength. Recommended for high frequency and rough service openings.

Thru Bolt

Wood or Metal Door - Type 1

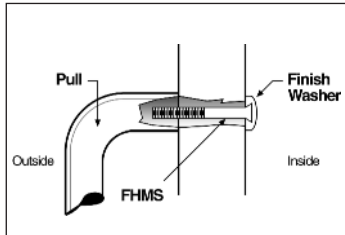

		Drill Size	
Type	Bolt Size	Wood	Metal
1	¼ - 20	⅜	⅜
1HD	⅜ - 18	1 1/32	1 1/32
1XHD	½ - 16	1 3/32	1 3/32

Wood or Metal Door - Type 12

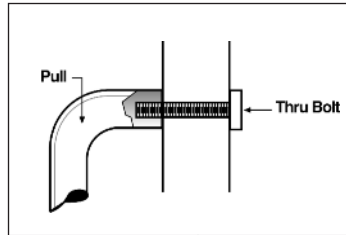

		Drill Size	
Type	Bolt Size	Wood	Metal
12	¼ - 20	⅜	⅜
12HD	⅜ - 18	1 1/32	1 1/32
12XHD	½ - 16	1 3/32	1 3/32

Glass Door - Type 15

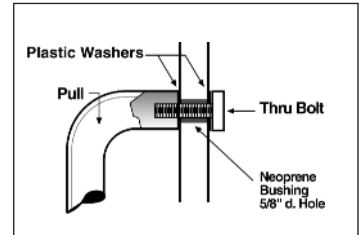

		Drill Size
Type	Bolt Size	Glass
15	¼ - 20	⅝
15HD	⅜ - 18	⅝
15XHD	½ - 16	⅝

Back to Back

Wood or Metal Door - Type 5

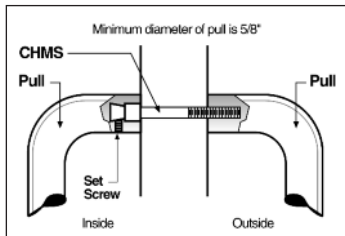

		Drill Size	
Type	Bolt Size	Wood	Metal
5	¼ - 20	⅜	⅜
5HD	⅜ - 18	1 1/32	1 1/32

Any Door Type - Type 9

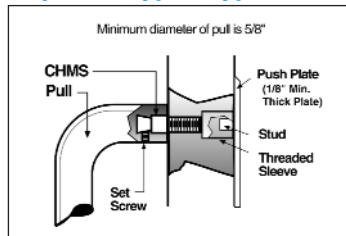

		Drill Size
Type	Bolt Size	Metal
9	¼ - 20	N/A

Glass Door - Type 13

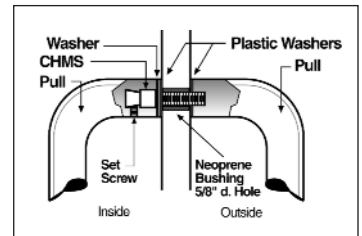

		Drill Size
Type	Bolt Size	Glass
13	¼ - 20	⅝
13HD	⅜ - 18	⅝

Surface Concealed

Metal Door - Type 6

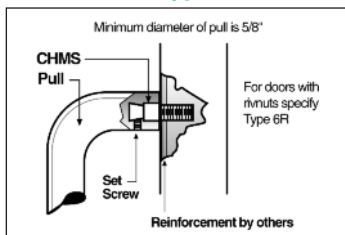

		Drill Size
Type	Bolt Size	Metal
6	¼ - 20	¼ - 20 tap
6HD	⅜ - 18	⅜ - 18 tap

Metal Door - Type 6R

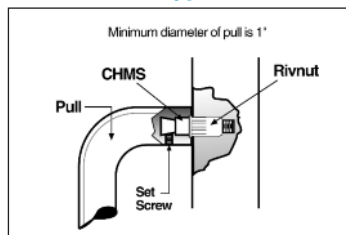

		Drill Size
Type	Bolt Size	Metal
6R	¼ - 20	N/A

Wood Door - Type 8

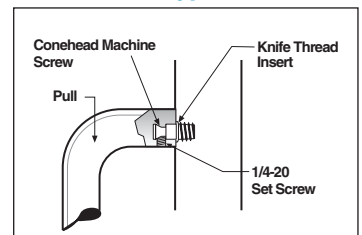

		Drill Size
Type	Bolt Size	Wood
8	¼ - 20	23/64 x 9/16 dp
8HD	⅜ - 18	7/16 x 9/16 dp

Flush Pull Mounting

Type 10 Mounting applies to the 94 Series Flush Pulls

Wood or Metal Door - Type 10

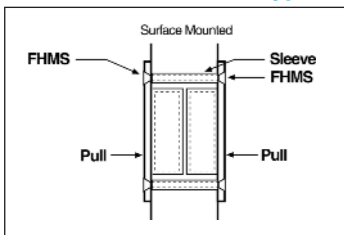

		Drill Size	
Type	Bolt Size	Wood	Metal
10	8 - 32	⅜	⅜

Wire or Small PostMount Pull Mounting

NOTE: This mounting should only be used on pulls with mounting points that are ½" in diameter.

Wood or Metal Door - Type 5S

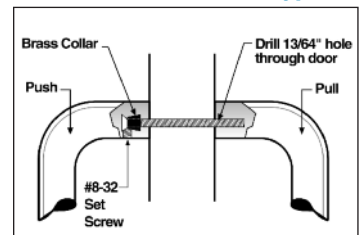

		Drill Size	
Type	Bolt Size	Wood	Metal
5S	8 - 32	13/64	13/64

Door Pulls
No. 102, 105, 106, 107, 108, 109



Material: Aluminum, Brass, Bronze, Stainless Steel

Finishes: Available in standard architectural finishes, US32D**MS**, US32D**316**, US32**316**, white (WPC), red (RPC), and black (BPC) powder coat finishes (see page 7).
 *US3**LIFETIME** available on select product below.

Fastener: 1/4-20 x 2 1/4 Thru Bolt & Finish Washer (standard 1 3/4" door).

- Options:**
- Back to back mounting in pairs — use BTB suffix and mounting type number (107BTB5).
 - Concealed mounting single pulls — use C suffix and mounting type number (107C6).
 - Advise if door thickness is other than 1 3/4".
 - See page B13 for mounting selection (standard duty 1/4-20).
 - 2 1/2" Barrier Free clearance — use BF prefix (BF107).

No.	Material Size	CTC	Overall	Base	Projection	Clearance	Weight	ANSI A156.6
102	5/8" dia.	5 1/2"	6 1/8"	5/8"	2"	1 3/8"	0.6 lbs.	—
105	3/4" dia.	5 1/2"	6 1/4"	3/4"	2 1/4"	1 1/2"	1.2 lbs.	J401
106	3/4" dia.	6"	6 3/4"	3/4"	2 1/4"	1 1/2"	1.3 lbs.	J401
107*	3/4" dia.	8"	8 3/4"	3/4"	2 1/4"	1 1/2"	1.6 lbs.	J401
108	3/4" dia.	10"	10 3/4"	3/4"	2 1/4"	1 1/2"	1.8 lbs.	J401
109	3/4" dia.	12"	12 3/4"	3/4"	2 1/4"	1 1/2"	2.1 lbs.	J401

Door Pulls
No. 110, 111A, 111, 112, 118



Material: Aluminum, Brass, Bronze, Stainless Steel

Finishes: Available in standard architectural finishes, US32D**MS**, US32D**316**, US32**316**, white (WPC), red (RPC), and black (BPC) powder coat finishes (see page 7).
 *US3**LIFETIME** available on select product below.

Fastener: 1/4-20 x 2 1/4 Thru Bolt & Finish Washer (standard 1 3/4" door).

- Options:**
- Back to back mounting in pairs — use BTB suffix and mounting type number (112BTB5).
 - Concealed mounting single pulls — use C suffix and mounting type number (112C6).
 - Advise if door thickness is other than 1 3/4".
 - Heavy duty versions of most fastening types available — use suffix HD to fastening type number (112BTB5HD).
 - See page B13 for mounting selection (standard duty 1/4-20).
 - 2 1/2" Barrier Free clearance — use BF prefix (BF110).

No.	Material Size	CTC	Overall	Base	Projection	Clearance	Weight	ANSI A156.6
110	1" dia.	8"	9"	1"	3"	2"	3.0 lbs.	J401
111A	1" dia.	9"	10"	1"	3"	2"	3.3 lbs.	J401
111*	1" dia.	10"	11"	1"	3"	2"	3.5 lbs.	J401
112*	1" dia.	12"	13"	1"	3"	2"	4.0 lbs.	J401
118	1" dia.	18"	19"	1"	3"	2"	5.4 lbs.	J401

T Series 1" Tubular Pulls

Rockwood’s new T Series 1” diameter straight tubular pulls are made from sturdy .065” thick wall tubing. Solid brass or stainless steel inserts are brazed into the ends to provide a solid area for our guaranteed mounting systems.

Benefits of specifying the T Series push and pulls include:

- Tubular pulls weigh 25% of their solid counterparts; this 75% weight reduction greatly reduces the environmental impact of harvesting material for their manufacture – a LEED certified building goal.
- The lighter weight minimizes the risk of damage in shipping and handling.
- The cost of most tubular pulls represents a significant savings over the equivalent solid model.

Considering all the benefits, the T Series pulls offer an improved value without any quality sacrifice.

T Series is also available in Offset pulls (see page B29) and in both Series 47 Push Bars and Push & Pull Bar sets (see pages A19 - A21).

**Tubular Door Pulls
No. T110, T111A, T111, T112, T118**



- Material:** Brass, Bronze, Stainless Steel
- Finishes:** Available in standard architectural finishes (see page 7).
- Fastener:** ¼-20 x 2¼ Thru Bolt & Finish Washer (standard 1¾" door).
- Options:**
- Back to back mounting in pairs — use BTB suffix and mounting type number (T112BTB5).
 - Concealed mounting single pulls — use C suffix and mounting type number (T112C6).
 - Advise if door thickness is other than 1¾".
 - See page B13 for mounting selection (standard duty ¼-20).
 - 2½" Barrier Free clearance — use BF prefix (TBF110).

No.	Material Size	CTC	Overall	Base	Projection	Clearance	Weight	ANSI A156.6
T110	1" dia.	8"	9"	1"	3"	2"	1.0 lbs.	—
T111A	1" dia.	9"	10"	1"	3"	2"	1.1 lbs.	J401
T111	1" dia.	10"	11"	1"	3"	2"	1.1 lbs.	J401
T112	1" dia.	12"	13"	1"	3"	2"	1.2 lbs.	J401
T118	1" dia.	18"	19"	1"	3"	2"	1.7 lbs.	J401

Pull Plate Sets/Security Door Pull

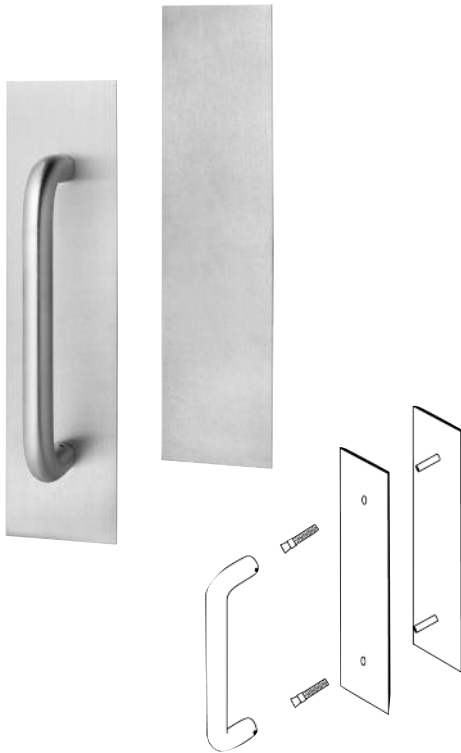

Concealed Mount Pull Plate Sets

No. 107x73B/73BL, 110x73C/73CL, 111x73C/73CL

Material: Stainless Steel

Finishes: US32D

Fastener: Type 9. Stud welded lugs on the back of the push plate are permanently attached to the 1/8" thick push plate. Cone Head MS attached to selected door pull.

Features:

- This set has no perimeter screw holes in either plate.
- Concealed mounting system. Any of the rod type door pulls from No. 105 to No. 118 are appropriate for this application.

Options:

- Engraving on plates 4" wide or wider. Specify copy. See page B1 for standard engraving locations.
- Cylinder Cutouts (CFC) and Turn Knob Cutouts (CFTT). See page B1 for standard locations and sizes.
- *Other overall sizes available upon request.

No.	Pull	Pull Size	Pull CTC	Pull Plate	Push Plate	Overall*	Weight	ANSI A156.6
107 x 73B/73BL	107	3/4" Dia.	8"	73B	73BL	3 1/2" x 15"	5.8	J406
110 x 73C/73CL	110	1" Dia.	8"	73C	73CL	4" x 16"	8.0	J406
111 x 73C/73CL	111	1" Dia.	10"	73C	73CL	4" x 16"	8.5	J406

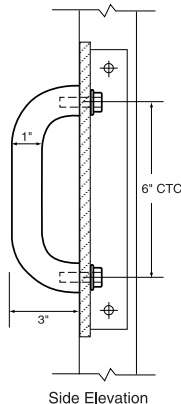

Security Door Pull No. 110-6SP

Material: Stainless Steel

Finishes: US32D

Fastener: 3/8"-16 Hex Head MS with nylon patch.

Features: For use on security hollow metal doors with reinforcing plate and access hole cover plate with TORX - security torx screws — all to be supplied by door manufacturer.

No.	Material Size	CTC	Overall	Base	Projection	Clearance	Weight	ANSI A156.6
110-6SP	1" dia.	6"	7"	1"	3"	2"	2.4 lbs.	J401

Door Pulls with Base Plates
No. Y102, Y105, Y106, Y107, Y108, Y109



- Material:** Aluminum, Brass, Bronze, Stainless Steel
- Finishes:** Available in standard architectural finishes, US32DMS, US32D316, US32316, white WPC), red (RPC), and black (BPC) powder coat finishes (see page 7).
- Fastener:** ¼-20 x 2½ Thru Bolt & Finish Washer (standard 1¾" door).
- Options:**
- Back to back mounting in pairs — use BTB suffix and mounting type number (Y107BTB5).
 - Concealed mounting single pulls — use C suffix and mounting type number (Y107C6).
 - Advise if door thickness is other than 1¾".
 - See page B13 for mounting selection (standard duty ¼-20).
- Features:** ⅛" base plates improve stability on the door. Recommended for glass and wood doors.

No.	Material Size	CTC	Overall	Base	Projection	Clearance	Weight	ANSI A156.6
Y102	⅝" dia.	5½"	6⅞"	⅞"	2⅛"	1½"	0.6 lbs.	—
Y105	¾" dia.	5½"	6⅞"	1⅜"	2⅜"	1⅝"	1.2 lbs.	J401
Y106	¾" dia.	6"	7⅞"	1⅜"	2⅜"	1⅝"	1.3 lbs.	J401
Y107	¾" dia.	8"	9⅞"	1⅜"	2⅜"	1⅝"	1.6 lbs.	J401
Y108	¾" dia.	10"	11⅞"	1⅜"	2⅜"	1⅝"	1.8 lbs.	J401
Y109	¾" dia.	12"	13⅞"	1⅜"	2⅜"	1⅝"	2.1 lbs.	J401

Door Pulls with Base Plates
No. Y110, Y111A, Y111, Y112, Y118



- Material:** Aluminum, Brass, Bronze, Stainless Steel
- Finishes:** Available in standard architectural finishes, US32DMS, US32D316, US32316, white (WPC), red (RPC), and black (BPC) powder coat finishes (see page 7).
- Fastener:** ¼-20 x 2½ Thru Bolt & Finish Washer (standard 1¾" door).
- Options:**
- Back to back mounting in pairs — use BTB suffix and mounting type number (Y112BTB5).
 - Concealed mounting single pulls — use C suffix and mounting type number (Y112C6).
 - Advise if door thickness is other than 1¾".
 - Heavy duty versions of most fastening types available — use suffix HD to fastening type number (112BTB5HD).
 - See page B13 for mounting selection (standard duty ¼-20).
- Features:** ⅛" base plates improve stability on the door. Recommended for glass and wood doors.

No.	Material Size	CTC	Overall	Base	Projection	Clearance	Weight	ANSI A156.6
Y110	1" dia.	8"	9¼"	1¼"	3⅞"	2⅛"	3.1 lbs.	J401
Y111A	1" dia.	9"	10¼"	1¼"	3⅞"	2⅛"	3.4 lbs.	J401
Y111	1" dia.	10"	11¼"	1¼"	3⅞"	2⅛"	3.6 lbs.	J401
Y112	1" dia.	12"	13¼"	1¼"	3⅞"	2⅛"	4.1 lbs.	J401
Y118	1" dia.	18"	19¼"	1¼"	3⅞"	2⅛"	5.5 lbs.	J401



**Door Pull
No. 120**

- Material:** Aluminum, Brass, Bronze, Stainless Steel
- Finishes:** Available in standard architectural finishes (see page 7).
- Fastener:** 1/4-20 x 2 1/4 Thru Bolt & Finish Washer (standard 1 3/4" door).
- Options:**
- Engraving available vertically.
 - Back to Back mounting.
 - Advise if door thickness is other than 1 3/4".
 - See page B13 for mounting selection (standard duty 1/4-20).

No.	Material Size	CTC	Overall	Base	Projection	Clearance	Weight	ANSI A156.6
120	3/8" x 1 1/4"	8"	14"	1" dia.	1 7/8"	1 3/8"	2.6 lbs.	J401



**Door Pull
No. 121**

- Material:** Aluminum, Brass, Bronze, Stainless Steel
- Finishes:** Available in standard architectural finishes (see page 7).
- Fastener:** 1/4-20 x 2 1/4 Thru Bolt & Finish Washer (standard 1 3/4" door).
- Options:**
- Engraving available vertically.
 - Back to Back mounting.
 - Advise if door thickness is other than 1 3/4".
 - See page B13 for mounting selection (standard duty 1/4-20).

No.	Material Size	CTC	Overall	Base	Projection	Clearance	Weight	ANSI A156.6
121	3/8" x 1 1/4"	8"	14"	1" dia.	1 7/8"	1 3/8"	2.6 lbs.	J401



**Door Pulls
No. 122, 123**

- Material:** Aluminum, Brass, Bronze, Stainless Steel
- Finishes:** Available in standard architectural finishes (see page 7).
- Fastener:** 1/4-20 x 2 1/4 Thru Bolt & Finish Washer (standard 1 3/4" door).
- Options:**
- Advise if door thickness is other than 1 3/4".
 - See page B13 for mounting selection (standard duty 1/4-20).

No.	Material Size	CTC	Overall	Projection	Clearance	Weight	ANSI A156.6
122	3/8" x 1 1/4"	6"	6 3/8"	2"	1 5/8"	1.1 lbs.	J401
123	3/8" x 1 1/4"	8"	8 3/8"	2"	1 5/8"	1.4 lbs.	J401



**Door Pulls
No. 125, 126**

- Material:** Aluminum, Brass, Bronze, Stainless Steel
Finishes: Available in standard architectural finishes (see page 7).
Fastener: ¼-20 x 2¼ Thru Bolt & Finish Washer (standard 1¾" door).
Options:
 - Advise if door thickness is other than 1¾".
 - See page B13 for mounting selection (standard duty ¼-20).

No.	Material Size	CTC	Overall	Projection	Clearance	Weight	ANSI A156.6
125	1" half round	6"	6½"	2"	1½"	1.1 lbs.	J401
126	1" half round	8"	8½"	2"	1½"	1.4 lbs.	J401



**Cast Door Pull
No. 130**

- Material:** Cast Aluminum, Brass, Stainless Steel
Finishes: Available in standard architectural finishes (see page 7).
Fastener: ¼-20 x 2¼ Thru Bolt & Finish Washer (standard 1¾" door).
Options:
 - Advise if door thickness is other than 1¾".
 - See page B13 for mounting selection (standard duty ¼-20).

No.	CTC	Overall	Base	Projection	Clearance	Weight	ANSI A156.6
130	5½"	7½"	2"	2¼"	1½"	1.1 lbs.	J401



**Cast Door Pull
No. 131**

- Material:** Cast Aluminum, Brass, Bronze, Stainless Steel
Finishes: Available in standard architectural finishes (see page 7).
Fastener: #8 x ¾ OHSMS

No.	CTC	Overall	Base	Projection	Clearance	Weight	ANSI A156.6
131	—	7½"	2"	2¼"	1½"	1.1 lbs.	J401



**Cast Door Pull
 No. 132**

- Material:** Cast Aluminum, Brass, Bronze, Stainless Steel
- Finishes:** Available in standard architectural finishes, US32DMS, and US3LIFETIME (see page 7).
- Fastener:** ¼-20 x 2¼ Thru Bolt & Finish Washer (standard 1¾" door).
- Options:**
- Advise if door thickness is other than 1¾".
 - See page B13 for mounting selection (standard duty ¼-20).

No.	CTC	Overall	Base	Projection	Clearance	Weight	ANSI A156.6
132	5½"	6¾"	7⁄8"	1⁄8"	1³⁄₈"	0.8 lbs.	J401



**Security Loop Door Pull
 No. D133**

- Material:** Brass, Stainless Steel
- Finishes:** US4, US32D, and US32DMS
- Fastener:** 2 ea. ⅜-16 x ⅝ OH Security Torx MS

No.	CTC	Overall	Base	Projection	Clearance	Weight	ANSI A156.6
D133	7¾"	8¾"	1¾" x 1⁷⁄₈"	2¼"	1¹¹⁄₁₆"	1.1 lbs.	J401



**Cast Door Pull
 No. 134**

- Material:** Cast Brass
- Finishes:** Available in standard architectural finishes (see page 7).
- Fastener:** ¼-20 x 2¼ Thru Bolt & Finish Washer (standard 1¾" door).
- Options:**
- Advise if door thickness is other than 1¾".
 - See page B13 for mounting selection (standard duty ¼-20).

No.	CTC	Overall	Base	Projection	Clearance	Weight	ANSI A156.6
134	7½"	8½"	1"	1⁄8"	1³⁄₈"	1.0 lbs.	J401



**Cast Door Pull
No. 137**

Material: Cast Brass, Stainless Steel

Finishes: Available in standard architectural finishes, and US32DMS (see page 7).

Fastener: ¼-20 x 2¼ Thru Bolt & Finish Washer (standard 1¾" door).

Options: • Advise if door thickness is other than 1¾".
• See page B13 for mounting selection (standard duty ¼-20).

No.	CTC	Overall	Base	Projection	Clearance	Weight	ANSI A156.6
137	5½"	6"	⅝" x 1¼"	2"	1½"	0.9 lbs.	J401



**Cast Door Pull
No. 137L**

Material: Cast Brass, Bronze

Finishes: Available in standard architectural finishes (see page 7).

Fastener: ¼-20 x 2¼ Thru Bolt & Finish Washer (standard 1¾" door).

Options: • Advise if door thickness is other than 1¾".
• See page B13 for mounting selection (standard duty ¼-20).

No.	CTC	Overall	Base	Projection	Clearance	Weight	ANSI A156.6
137L	10"	10¾"	⅝" x 1¼"	2½"	1¾"	1.1 lbs.	J401



**Cast Door Pull
No. 138**

Material: Cast Aluminum, Brass

Finishes: Available in standard architectural finishes (see page 7).

Fastener: ¼-20 x 2¼ Thru Bolt & Finish Washer (standard 1¾" door).

Options: • Advise if door thickness is other than 1¾".
• See page B13 for mounting selection (standard duty ¼-20).

No.	CTC	Overall	Base	Projection	Clearance	Weight	ANSI A156.6
138	7½"	9½"	2"	2⅝"	1½"	1.5 lbs.	J401



**Cast Door Pull
No. 139**

Material: Cast Aluminum, Brass

Finishes: Available in standard architectural finishes (see page 7).

Fastener: #8 x ¾ OHSMS

No.	CTC	Overall	Base	Projection	Clearance	Weight	ANSI A156.6
139	—	9½"	2"	2⅝"	1½"	1.5 lbs.	J401

Door Pulls
No. 147, 147L



- Material:** Cast Brass
- Finishes:** Available in standard architectural finishes (see page 7). *US3**LIFETIME** available on select product below.
- Fastener:** ¼-20 x 2¼ Thru Bolt & Finish Washer (standard 1¾" door).
- Options:** Elliptical base plates (see Architectural Hardware Catalog, page 73).
- Options:**
- Advise if door thickness is other than 1¾".
 - See page B13 for mounting selection (standard duty ¼-20).

No.	CTC	Overall	Base	Projection	Clearance	Weight	ANSI A156.6
147*	6"	7½"	1½" dia.	2½"	1¾"	1.2 lbs.	J401
147L	12"	13¾"	1⅞" dia.	2⅝"	1⅞"	1.7 lbs.	J401

Door Pull
No. 148



- Material:** Cast Brass
- Finishes:** Available in standard architectural finishes, and US3**LIFETIME** (see page 7).
- Fastener:** ¼-20 x 2¼ Thru Bolt & Finish Washer (standard 1¾" door).
- Options:**
- Type 5 Back to Back mounting.
 - Advise if door thickness is other than 1¾".
 - See page B13 for mounting selection (standard duty ¼-20).

No.	CTC	Overall	Base	Projection	Clearance	Weight	ANSI
148	8"	8⅞"	1⅝"	2¼"	1¼"	1.5 lbs.	J401

Door Pull
No. 149



- Material:** Cast Brass
- Finishes:** Available in standard architectural finishes, and US3**LIFETIME** (see page 7).
- Fastener:** ¼-20 x 2¾ Thru Bolt & Finish Washer (standard 1¾" door).
- Options:**
- Type 5 Back to Back mounting.
 - Advise if door thickness is other than 1¾".
 - See page B13 for mounting selection (standard duty ¼-20).

No.	CTC	Overall	Base	Projection	Clearance	Weight	ANSI
149	8"	9¾"	1¾"	2⅝"	1⅝"	1.8 lbs.	J401



Pull Plates

No. 102 x 70, 105 x 70, 106 x 70, 107 x 70

Material: Aluminum, Brass, Bronze, Stainless Steel

Finishes: Stocked in standard architectural finishes but available in any finish, US32DMS, US32D316, and US32316 (see page 7).
*US3LIFETIME available on select product below.

Fastener: #6 x 5/8 OHSMS; 1/4-20 x 2 1/4 Thru Bolt & Finish Washer (standard 1 3/4" door).

- Options:**
- Barrier Free available in 2 1/2" clearance — use BF prefix when ordering (BF102 x 70C).
 - Advise if door thickness is other than 1 3/4".
 - See page B13 for mounting selection (standard duty 1/4-20).

No.	Pull	CTC	Plate	Size	Weight	ANSI A156.6
102 x 70B	5/8" dia.	5 1/2"	70	3 1/2" x 15"	1.8 lbs.	J405
102 x 70C	5/8" dia.	5 1/2"	70	4" x 16"	1.9 lbs.	J405
105 x 70B	3/4" dia.	5 1/2"	70	3 1/2" x 15"	2.1 lbs.	J405
105 x 70C	3/4" dia.	5 1/2"	70	4" x 16"	2.2 lbs.	J405
106 x 70B	3/4" dia.	6"	70	3 1/2" x 15"	2.2 lbs.	J405
106 x 70C	3/4" dia.	6"	70	4" x 16"	2.3 lbs.	J405
107 x 70B*	3/4" dia.	8"	70	3 1/2" x 15"	2.4 lbs.	J405
107 x 70C*	3/4" dia.	8"	70	4" x 16"	2.5 lbs.	J405

Pull Plates

No. 110 x 70, 111 x 70

Material: Aluminum, Brass, Bronze, Stainless Steel

Finishes: Stocked in standard architectural finishes but available in any finish, US32DMS, US32D316, and US32316 (see page 7).
*US3LIFETIME available on select product below.

Fastener: #6 x 5/8 OHSMS; 1/4-20 x 2 1/4 Thru Bolt & Finish Washer (standard 1 3/4" door).

- Options:**
- Barrier Free available in 2 1/2" clearance — use BF prefix when ordering (BF110 x 70C).
 - Advise if door thickness is other than 1 3/4".
 - See page B13 for mounting selection (standard duty 1/4-20).



No.	Pull	CTC	Plate	Size	Weight	ANSI A156.6
110 x 70B	1" dia.	8"	70	3 1/2" x 15"	3.8 lbs.	J405
110 x 70C	1" dia.	8"	70	4" x 16"	3.9 lbs.	J405
111 x 70B*	1" dia.	10"	70	3 1/2" x 15"	4.3 lbs.	J405
111 x 70C*	1" dia.	10"	70	4" x 16"	4.4 lbs.	J405



Pull Plates No. 122 x 70, 123 x 70

- Material:** Aluminum, Brass, Bronze, Stainless Steel
- Finishes:** Stocked in standard architectural finishes but available in any finish (see page 7).
- Fastener:** #6 x 5/8 OHSMS; 1/4-20 x 2 1/4 Thru Bolt & Finish Washer (standard 1 3/4" door).
- Options:**
- Advise if door thickness is other than 1 3/4".
 - See page B13 for mounting selection (standard duty 1/4-20).

No.	Pull	CTC	Plate	Size	Weight	ANSI A156.6
122 x 70B	3/8" x 1 1/4"	6"	70	3 1/2" x 15"	2.2 lbs.	J405
122 x 70C	3/8" x 1 1/4"	6"	70	4" x 16"	2.3 lbs.	J405
123 x 70B	3/8" x 1 1/4"	8"	70	3 1/2" x 15"	2.5 lbs.	J405
123 x 70C	3/8" x 1 1/4"	8"	70	4" x 16"	2.6 lbs.	J405



Pull Plates No. 125 x 70, 126 x 70

- Material:** Aluminum, Brass, Bronze, Stainless Steel
- Finishes:** Stocked in standard architectural finishes but available in any finish (see page 7).
- Fastener:** #6 x 5/8 OHSMS; 1/4-20 x 2 1/4 Thru Bolt & Finish Washer (standard 1 3/4" door).
- Options:**
- Advise if door thickness is other than 1 3/4".
 - See page B13 for mounting selection (standard duty 1/4-20).

No.	Pull	CTC	Plate	Size	Weight	ANSI A156.6
125 x 70B	1" half round	6"	70	3 1/2" x 15"	2.0 lbs.	J405
125 x 70C	1" half round	6"	70	4" x 16"	2.1 lbs.	J405
126 x 70B	1" half round	8"	70	3 1/2" x 15"	2.3 lbs.	J405
126 x 70C	1" half round	8"	70	4" x 16"	2.4 lbs.	J405

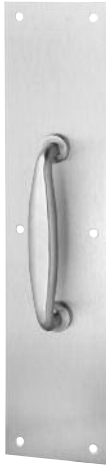

**Pull Plates
No. 132 x 70**

- Material:** Aluminum, Brass, Bronze, Stainless Steel
- Finishes:** Stocked in standard architectural finishes but available in any finish, US32DMS, and US3LIFETIME (see page 7).
- Fastener:** #6 x 5/8 OHSMS; 1/4-20 x 2 1/4 Thru Bolt & Finish Washer (standard 1 3/4" door).
- Options:**
- Advise if door thickness is other than 1 3/4".
 - See page B13 for mounting selection (standard duty 1/4-20).

No.	Pull	CTC	Plate	Size	Weight	ANSI A156.6
132 x 70B	cast	5 1/2"	70	3 1/2" x 15"	1.7 lbs.	J405
132 x 70C	cast	5 1/2"	70	4" x 16"	1.8 lbs.	J405

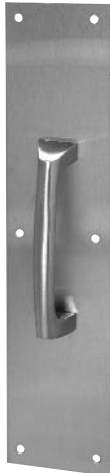

**Pull Plates
No. 137 x 70**

- Material:** Brass, Stainless Steel
- Finishes:** Stocked in standard architectural finishes but available in any finish (see page 7).
- Fastener:** #6 x 5/8 OHSMS; 1/4-20 x 2 1/4 Thru Bolt & Finish Washer (standard 1 3/4" door).
- Options:**
- Advise if door thickness is other than 1 3/4".
 - See page B13 for mounting selection (standard duty 1/4-20).

No.	Pull	CTC	Plate	Size	Weight	ANSI A156.6
137 x 70B	cast	5 1/2"	70	3 1/2" x 15"	1.7 lbs.	J405
137 x 70C	cast	5 1/2"	70	4" x 16"	1.8 lbs.	J405



No. 147 x 76B



No. 147 x 77B

Pull Plates

No. 147 x 76, 147 x 77

Material: Cast Brass

Finishes: Stocked in standard architectural finishes, and US3**LIFETIME** (see page 7).

Fastener: #6 x 5/8 OHSMS; 1/4-20 x 2 1/4 Thru Bolt & Finish Washer (standard 1 3/4" door).

- Options:**
- Advise if door thickness is other than 1 3/4".
 - See page B13 for mounting selection (standard duty 1/4-20).

No.	Pull	CTC	Plate	Size	Weight	ANSI A156.6
147 x 76B	cast	6"	76	3 1/2" x 15"	2.1 lbs.	J405
147 x 76C	cast	6"	76	4" x 16"	2.2 lbs.	J405
147 x 77B	cast	6"	77	3 1/2" x 15"	2.1 lbs.	J405
147 x 77C	cast	6"	77	4" x 16"	2.2 lbs.	J405



No. 148 x 76B



No. 148 x 77B

Pull Plates

No. 148 x 76, 148 x 77

Material: Cast Brass

Finishes: Stocked in standard architectural finishes, and US3**LIFETIME** (see page 7).

Fastener: #6 x 5/8 OHSMS; 1/4-20 x 2 1/4 Thru Bolt & Finish Washer (standard 1 3/4" door).

- Options:**
- Advise if door thickness is other than 1 3/4".
 - See page B13 for mounting selection (standard duty 1/4-20).

No.	Pull	CTC	Plate	Size	Weight	ANSI A156.6
148 x 76B	cast	8"	76	3 1/2" x 15"	2.7 lbs.	J405
148 x 76C	cast	8"	76	4" x 16"	2.8 lbs.	J405
148 x 77B	cast	8"	77	3 1/2" x 15"	2.7 lbs.	J405
148 x 77C	cast	8"	77	4" x 16"	2.8 lbs.	J405

Offset Door Pulls Mounting Details

NOTE: Y base plates are recommended on wood or glass doors to make a stable and durable mounting.

NOTE: Heavy Duty (HD/XHD) mounting features hex drive for positive tightening and large overall size for superior strength. Recommended for high frequency and rough service openings.

Thru Bolt

Wood or Metal Door - Type 1

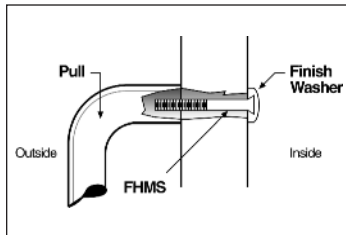

		Drill Size	
Type	Bolt Size	Wood	Metal
1	1/4 - 20	3/32	3/32
1HD	5/16 - 18	11/32	11/32
1XHD	3/8 - 16	13/32	13/32

Wood or Metal Door - Type 12

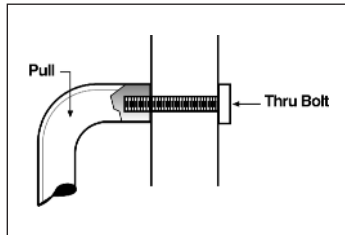

		Drill Size	
Type	Bolt Size	Wood	Metal
12	1/4 - 20	3/32	3/32
12HD	5/16 - 18	11/32	11/32
12XHD	3/8 - 16	13/32	13/32

Glass Door - Type 15

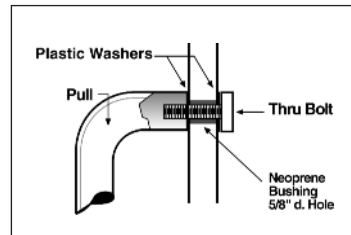

		Drill Size
Type	Bolt Size	Glass
15	1/4 - 20	5/8
15HD	5/16 - 18	5/8
15XHD	3/8 - 16	5/8

Back to Back

Wood or Metal Door - Type 16

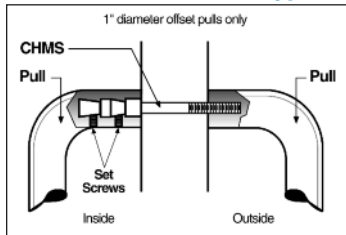

		Drill Size	
Type	Bolt Size	Wood	Metal
16	1/4 - 20	3/32	3/32
16HD	5/16 - 18	11/32	11/32

Glass Door - Type 18

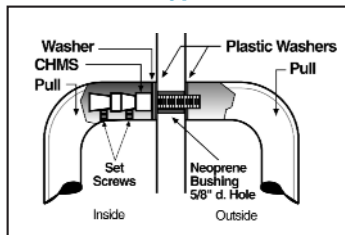

		Drill Size
Type	Bolt Size	Glass
18	1/4 - 20	5/8
18HD	5/16 - 18	5/8

Concealed

Metal Door - Type 17

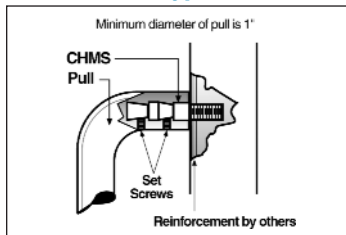

		Drill Size
Type	Bolt Size	Metal
17	1/4 - 20	1/4-20 tap
17HD	5/16 - 18	5/16-18 tap

Metal Door - Type 17R

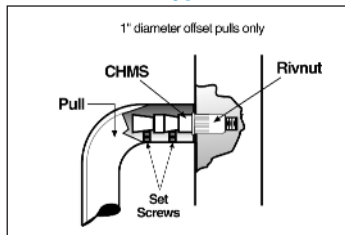

		Drill Size
Type	Bolt Size	Metal
17R	1/4 - 20	N/A

90° Offset Door Pulls
No. BF150, BF151, BF152



Material: Aluminum, Brass, Bronze, Stainless Steel

Finishes: Available in standard architectural finishes, US32DMS, US32D316, US32316, white (WPC), red (RPC), and black (BPC) powder coat finishes (see page 7).

Fastener: ¼-20 x 2¼ Thru Bolt & Finish Washer (standard 1¾" door).

- Options:**
- Back to back mounting in pairs — use BTB suffix and mounting type number (BF150BTB16).
 - Concealed mounting single pulls — use C suffix and mounting type number (BF150C17).
 - Advise if door thickness is other than 1¾".
 - See page B27 for mounting selection (standard duty ¼-20).

No.	Material Size	CTC	Overall	Base	Projection	Clearance	Offset	Weight	ANSI A156.6
BF150	¾" dia.	8"	8¾"	¾"	3¼"	2½"	4"	2.3 lbs.	J402
BF151	¾" dia.	10"	10¾"	¾"	3¼"	2½"	4"	2.5 lbs.	J402
BF152	¾" dia.	12"	12¾"	¾"	3¼"	2½"	4"	2.7 lbs	J402

90° Offset Door Pulls
No. BF156, BF157A, BF157, BF158, BF159

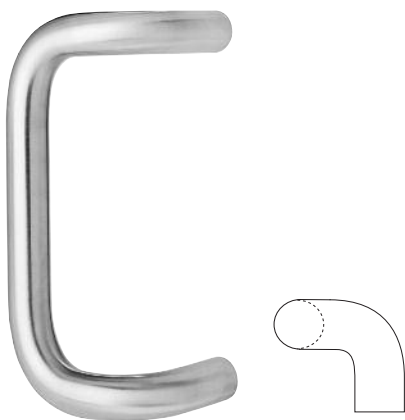

Material: Aluminum, Brass, Bronze, Stainless Steel

Finishes: Available in standard architectural finishes, US32DMS, US32D316, US32316, white (WPC), red (RPC), and black (BPC) powder coat finishes (see page 7). *US3LIFETIME available on select product below.

Fastener: ¼-20 x 2¼ Thru Bolt & Finish Washer (standard 1¾" door).

- Options:**
- Back to back mounting in pairs — use BTB suffix and mounting type number (BF156BTB16).
 - Concealed mounting single pulls — use C suffix and mounting type number (BF156C17).
 - Advise if door thickness is other than 1¾".
 - Heavy duty versions of most fastening types available — use suffix HD to fastening type number (BF156BTB16HD).
 - See page B27 for mounting selection (standard duty ¼-20).

Features: Recommended for ADA openings.

No.	Material Size	CTC	Overall	Base	Projection	Clearance	Offset	Weight	ANSI A156.6
BF156	1" dia.	8"	9"	1"	3½"	2½"	4"	3.9 lbs.	J402
BF157A	1" dia.	9"	10"	1"	3½"	2½"	4"	4.1 lbs.	J402
BF157*	1" dia.	10"	11"	1"	3½"	2½"	4"	4.3 lbs.	J402
BF158	1" dia.	12"	13"	1"	3½"	2½"	4"	4.8 lbs.	J402
BF159	1" dia.	18"	19"	1"	3½"	2½"	4"	6.5 lbs.	J402

T Series 1" Tubular Pulls

Rockwood's new T Series 1" diameter offset tubular pulls are made from sturdy .065" thick wall tubing. Solid brass or stainless steel inserts are brazed into the ends to provide a solid area for our guaranteed mounting systems.

Benefits of specifying the T Series push and pulls include:

- Tubular pulls weigh 25% of their solid counterparts; this 75% weight reduction greatly reduces the environmental impact of harvesting material for their manufacture – a LEED certified building goal.
- The lighter weight minimizes the risk of damage in shipping and handling.
- The cost of most tubular pulls represents a significant savings over the equivalent solid model.

Considering all the benefits, the T Series pulls offer an improved value without any quality sacrifice.

T Series is also available in Straight pulls (see page B15) and in both Series 47 Push Bars and Push & Pull Bar sets (see pages A19 - A21).

**90° Offset Tubular Door Pulls
No. TBF156, TBF157A, TBF157, TBF158, TBF159**

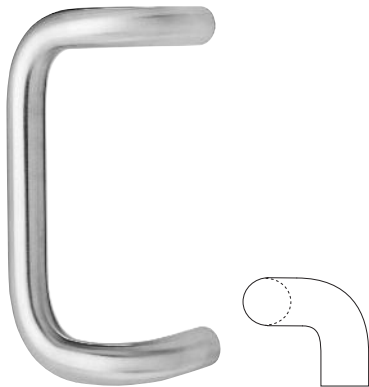

- Material:** Brass, Bronze, Stainless Steel
- Finishes:** Available in standard architectural finishes (see page 7).
- Fastener:** ¼-20 x 2¼ Thru Bolt & Finish Washer (standard 1¾" door).
- Options:**
- Back to back mounting in pairs — use BTB suffix and mounting type number (TBF156BTB16).
 - Concealed mounting single pulls — use C suffix and mounting type number (TBF156C17).
 - Advise if door thickness is other than 1¾".
 - See page B27 for mounting selection (standard duty ¼-20).
- Features:** Recommended for ADA openings.

No.	Material Size	CTC	Overall	Base	Projection	Clearance	Offset	Weight	ANSI A156.6
TBF156	1" dia.	8"	9"	1"	3½"	2½"	4"	1.3 lbs.	J402
TBF157A	1" dia.	9"	10"	1"	3½"	2½"	4"	1.4 lbs.	J402
TBF157	1" dia.	10"	11"	1"	3½"	2½"	4"	1.4 lbs.	J402
TBF158	1" dia.	12"	13"	1"	3½"	2½"	4"	1.5 lbs.	J402
TBF159	1" dia.	18"	19"	1"	3½"	2½"	4"	2.0 lbs.	J402

90° Offset Door Pulls with Base Plates
No. YBF150, YBF151, YBF152

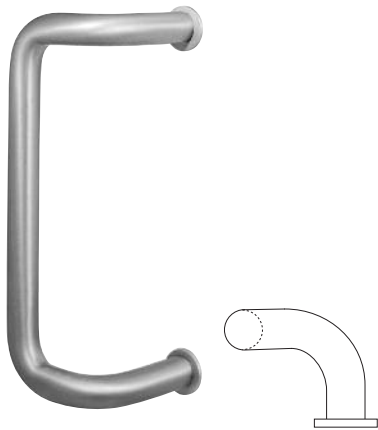

Material: Aluminum, Brass, Bronze, Stainless Steel

Finishes: Available in standard architectural finishes, US32DMS, US32D316, US32316, white (WPC), red (RPC), and black (BPC) powder coat finishes (see page 7).

Fastener: ¼-20 x 2½ Thru Bolt & Finish Washer (standard 1¾" door).

- Options:**
- Back to back mounting in pairs — use BTB suffix and mounting type number (YBF150BTB16).
 - Concealed mounting single pulls — use C suffix and mounting type number (YBF150C17).
 - Advise if door thickness is other than 1¾".
 - See page B27 for mounting selection (standard duty ¼-20).

Features: Base plates improve stability on all doors and are especially recommended for use on wood and glass doors.

No.	Material Size	CTC	Overall	Base	Projection	Clearance	Offset	Weight	ANSI A156.6
YBF150	¾" dia.	8"	9¼"	1½"	¾"	2⅝"	3"	2.4 lbs.	J402
YBF151	¾" dia.	10"	11¼"	1½"	¾"	2⅝"	3"	2.6 lbs.	J402
YBF152	¾" dia.	12"	13¼"	1½"	¾"	2⅝"	3"	2.8 lbs.	J402

90° Offset Door Pulls with Base Plates
No. YBF156, YBF157A, YBF157, YBF158, YBF159

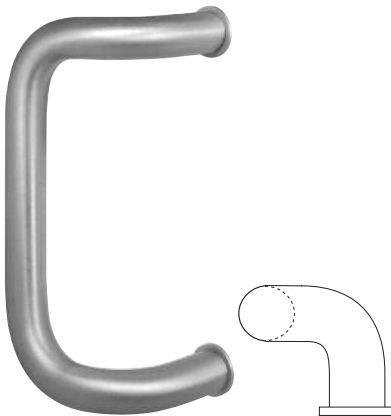

Material: Aluminum, Brass, Bronze, Stainless Steel

Finishes: Available in standard architectural finishes, US32DMS, US32D316, US32316, white (WPC), red (RPC), and black (BPC) powder coat finishes (see page 7). *US3LIFETIME available on select product below.

Fastener: ¼-20 x 2½ Thru Bolt & Finish Washer (standard 1¾" door).

- Options:**
- Back to back mounting in pairs — use BTB suffix and mounting type number (YBF156BTB16).
 - Concealed mounting single pulls — use C suffix and mounting type number (YBF156C17).
 - Advise if door thickness is other than 1¾".
 - Heavy duty versions of most fastening types available — use suffix HD to fastening type number (YBF156BTB16HD).
 - See page B27 for mounting selection (standard duty ¼-20).

Features:

- Recommended for ADA openings.
- Base plates improve stability on all doors and are especially recommended for use on wood and glass doors.

No.	Material Size	CTC	Overall	Base	Projection	Clearance	Offset	Weight	ANSI A156.6
YBF156	1" dia.	8"	9¼"	1¼"	3⅝"	2⅝"	4"	4.0 lbs.	J402
YBF157A	1" dia.	9"	10¼"	1¼"	3⅝"	2⅝"	4"	4.2 lbs.	J402
YBF157*	1" dia.	10"	11¼"	1¼"	3⅝"	2⅝"	4"	4.4 lbs.	J402
YBF158	1" dia.	12"	13¼"	1¼"	3⅝"	2⅝"	4"	4.9 lbs.	J402
YBF159	1" dia.	18"	19¼"	1¼"	3⅝"	2⅝"	4"	6.6 lbs.	J402

45° Offset Door Pulls
No. BF160, BF161, BF162

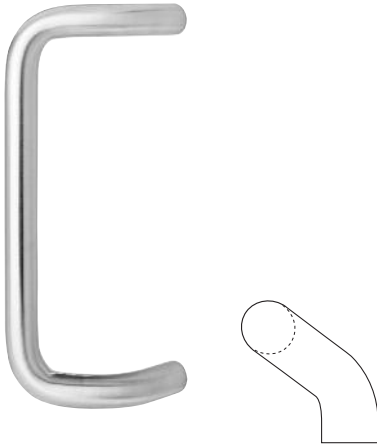

Material: Aluminum, Brass, Bronze, Stainless Steel

Finishes: Available in standard architectural finishes, US32D**M**S, US32D**316**, US32**316**, white (WPC), red (RPC), and black (BPC) powder coat finishes (see page 7).

Fastener: ¼-20 x 2¼ Thru Bolt & Finish Washer (standard 1¾" door).

- Options:**
- Back to back mounting in pairs — use BTB suffix and mounting type number (BF160BTB16).
 - Concealed mounting single pulls — use C suffix and mounting type number (BF160C17).
 - Advise if door thickness is other than 1¾".
 - See page B27 for mounting selection (standard duty ¼-20).
 - Use Y prefix (YBF160) when ordering pulls with base plates, Y plate diameter is 1½"; recommended for use on wood and glass doors.

No.	Material Size	CTC	Overall	Base	Projection	Clearance	Offset	Weight	ANSI A156.6
BF160	¾" dia.	8"	8¾"	¾"	3¼"	2½"	3"	1.8 lbs.	J402
BF161	¾" dia.	10"	10¾"	¾"	3¼"	2½"	3"	2.0 lbs.	J402
BF162	¾" dia.	12"	12¾"	¾"	3¼"	2½"	3"	2.2 lbs.	J402

45° Offset Door Pulls
No. BF166, BF167A, BF167, BF168, BF169

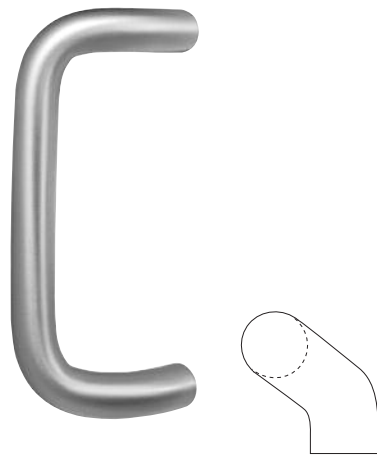

Material: Aluminum, Brass, Bronze, Stainless Steel

Finishes: Available in standard architectural finishes, US32D**M**S, US32D**316**, US32**316**, white (WPC), red (RPC), and black (BPC) powder coat finishes (see page 7).

Fastener: ¼-20 x 2¼ Thru Bolt & Finish Washer (standard 1¾" door).

- Options:**
- Back to back mounting in pairs — use BTB suffix and mounting type number (BF166BTB16).
 - Concealed mounting single pulls — use C suffix and mounting type number (BF166C17).
 - Advise if door thickness is other than 1¾".
 - Heavy duty versions of most fastening types available — use suffix HD to fastening type number (BF166BTB16HD).
 - See page B27 for mounting selection (standard duty ¼-20).
 - Use Y prefix (YBF166) when ordering pulls with base plates, Y plate diameter is 1¾"; recommended for use on wood and glass doors.

No.	Material Size	CTC	Overall	Base	Projection	Clearance	Offset	Weight	ANSI A156.6
BF166	1" dia.	8"	9"	1"	3½"	2½"	3"	2.8 lbs.	J402
BF167A	1" dia.	9"	10"	1"	3½"	2½"	3"	3.0 lbs.	J402
BF167	1" dia.	10"	11"	1"	3½"	2½"	3"	3.2 lbs.	J402
BF168	1" dia.	12"	13"	1"	3½"	2½"	3"	3.6 lbs.	J402
BF169	1" dia.	18"	19"	1"	3½"	2½"	3"	5.0 lbs.	J402

Offset Door Pulls/Vandal Resistant Trim

Heavy Duty Offset Door Pulls
No. BF257, BF258, BF259, BF260

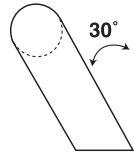

- Material:** Aluminum, Brass, Bronze, Stainless Steel
- Finishes:** Available in standard architectural finishes, US32DMS, US32D316, US32316, white (WPC), red (RPC), and black (BPC) powder coat finishes (see page 7).
- Fastener:** 3/8-16 x 2 1/2 Thru Bolt & finish washer (standard 1 3/4" door).
- Features:**
- Heavy duty pull and mounting for rough service areas.
 - Large footprint on door provides stable mounting.
- Options:**
- Advise if door thickness is other than 1 3/4".
 - See page B27 for mounting selection.

No.	Material Size	CTC	Overall	Base	Projection	Clearance	Offset	Weight	ANSI A156.6
BF257	1 1/4" dia.	10"	11 1/4"	1 1/4" x 1 7/16"	3 3/4"	2 1/2"	1 15/16"	8.3 lbs.	J402
BF258	1 1/4" dia.	12"	13 1/4"	1 1/4" x 1 7/16"	3 3/4"	2 1/2"	1 15/16"	9.0 lbs.	J402
BF259	1 1/4" dia.	18"	19 1/4"	1 1/4" x 1 7/16"	3 3/4"	2 1/2"	1 15/16"	11.1 lbs.	J402
BF260	1 1/4" dia.	24"	25 1/4"	1 1/4" x 1 7/16"	3 3/4"	2 1/2"	1 15/16"	13.3 lbs.	J402



No. VRT12



No. VRT22

Vandal Resistant Trim
No. VRT12, VRT22

- Material:** Stainless Steel
- Finishes:** US32D
- Fastener:** 1/4-20 Thru Bolt. Other sizes to match locks and exit devices as required.
- Options:**
- Cut for cylinder — use C suffix (VRT22C) when ordering.
 - Specify make and model number of exit device when mounting with exit device fastening systems.
- Features:** VRT22 — soft black textured grip.

No.	Material Size	Weight
VRT12	5 7/8" x 12"	2.3 lbs.
VRT22	5 7/8" x 12"	2.3 lbs.

**Vandal Resistant Trim
No. VRT14, VRT16, VRT24, VRT26**



No. VRT14



No. VRT16



No. VRT24



No. VRT26

Material: Stainless Steel

Finishes: US32D

Fastener: 1/4"-20 Thru Bolt. Other sizes to match locks and exit devices as required.

- Options:**
- Cut for cylinder use C suffix (VRT24C) when ordering.
 - Specify make and model number of exit device when mounting with exit device fastening systems.

- Features:**
- Ideal pull for the exterior doors on schools and other public buildings as well as the rear exit doors of commercial and industrial buildings.
 - Anti-vandal design minimizes opportunity for tampering.
 - No exposed fasteners.
 - Supplied with thru bolts for non-integrated mounting or can be supplied with mounting points to mate with exit device or mortise lock.
 - Patent applied for.

No.	Integral Latch Guard	Textured Black Grip	Overall Size	Weight
VRT14	Yes	No	1/8" x 7 x 12	3.2 lbs.
VRT16	No	No	1/8" x 5 1/2 x 12	2.5 lbs.
VRT24	Yes	Yes	1/8" x 7 x 12	3.2 lbs.
VRT26	No	Yes	1/8" x 5 1/2 x 12	2.5 lbs.

Required Order Information (Please supply all required templates.)

Quantity	Product #	Mating Manufacturer	Part #	Device Template #	Template # for Cylinder Hole Location	Cylinder Diameter	Door Handing	Single of Pair	Finish



**Offset Door Pull
 No. 176**

- Material:** Aluminum, Brass, Bronze, Stainless Steel
- Finishes:** Available in standard architectural finishes, except US26 and US26D (see page 7).
- Fastener:** 1/4-20 x 2 1/4 Thru Bolt & Finish Washer (standard 1 3/4" door).
- Options:**
- Engraving "PUSH" or "PULL" or a corporate logo. Email artwork file for quicker service.
 - Advise if door thickness is other than 1 3/4".
 - See page B27 for mounting selection (standard duty 1/4-20).

No.	Material Size	CTC	Base	Projection	Clearance	Weight	ANSI A156.6
176	6" x 12"	10"	1 3/8" x 12"	2 1/4"	1 7/8"	6.8 lbs.	J409



**Offset Door Pull
 No. 177**

- Material:** Aluminum, Brass, Bronze, Stainless Steel
- Finishes:** Available in standard architectural finishes, except US26 and US26D (see page 7).
- Fastener:** 1/4-20 x 2 1/4 Thru Bolt & Finish Washer (standard 1 3/4" door).
- Options:**
- Engraving "PUSH" or "PULL" or a corporate logo. Email artwork file for quicker service.
 - Advise if door thickness is other than 1 3/4".
 - See page B27 for mounting selection (standard duty 1/4-20).

No.	Material Size	CTC	Base	Projection	Clearance	Weight	ANSI A156.6
177	6" x 12"	10"	1 3/8" x 12"	2 1/4"	1 7/8"	3.3 lbs.	J409



**Offset Door Pull
 No. 185**

- Material:** Aluminum, Brass, Bronze, Stainless Steel
- Finishes:** Available in standard architectural finishes, except US26 and US26D (see page 7).
- Fastener:** 1/4-20 x 2 1/4 Thru Bolt & Finish Washer (standard 1 3/4" door).
- Options:**
- Engraving "PUSH" or "PULL" or a corporate logo. Email artwork file for quicker service.
 - Advise if door thickness is other than 1 3/4".
 - See page B27 for mounting selection (standard duty 1/4-20).

No.	Material Size	CTC	Base	Projection	Clearance	Weight	ANSI A156.6
185	5" x 12"	10"	1" x 12"	2 3/8"	1 7/8"	12.5 lbs.	J409



**Hospital Door Pull
No. 193**

Material: Cast Brass, Stainless Steel
Finishes: Available in standard architectural finishes, and US32DMS (see page 7).
Fastener: #8 x 3/4 OH SMS

No.	Material	CTC	Overall	Base	Projection	Clearance	Weight	ANSI A156.6
193	cast	5 5/16"	9 1/4"	1 1/2" x 1 1/2"	3 1/2"	1 5/8"	0.9 lbs.	J401

**Wooden Door Pull
No. 208**



Material: Maple, Oak, Walnut, Cherry (other woods available upon request)
Finishes: Brackets available in standard architectural finishes (see page 7). Wood available in Oiled or Clear Finish.
Fastener: 1/4-20 x 2 1/4 Thru Bolt & Finish Washer (standard 1 3/4" door).
Ordering: Specify type of material, finish of wood, and finish of metal brackets.
Options:

- Use Y prefix (Y208) when ordering pulls with base plates, Y plate diameter is 1 1/16"; recommended for use on glass or wood doors.
- Back to back mounting — use BTB suffix (208BTB) when ordering two pulls back to back. See page B13 for mounting details.
- Other sizes and shapes available; contact factory.
- Advise if door thickness is other than 1 3/4".

No.	Grip	CTC	Overall	Base	Projection	Clearance	Weight	ANSI A156.6
208	1"	8"	15"	3/4" dia.	2 1/2"	1 3/4"	1.9 lbs.	J401

**Tapered Door Pulls
No. 215, 215L**



Material: Aluminum, Brass, Bronze, Stainless Steel
Finishes: Available in standard architectural finishes, and US32DMS (see page 7).
Fastener: 1/4-20 x 2 1/4 Thru Bolt & Finish Washer (standard 1 3/4" door).
Options:

- Use Y prefix (Y215) when ordering pulls with base plates, Y plate diameter is 1 1/16"; recommended for use on glass or wood doors.
- Back to back mounting — use BTB suffix (215BTB) when ordering two pulls back to back. See page B13 for mounting details.
- Advise if door thickness is other than 1 3/4".

No.	Material Size	CTC	Overall	Base	Projection	Clearance	Weight	ANSI A156.6
215	1" dia.	8"	16"	3/4" dia.	2 1/2"	1 1/2"	3.5 lbs.	J401
215L	1 1/4" dia.	12"	28"	3/4" dia.	2 3/4"	1 1/2"	9.4 lbs.	J401

ROCKWOOD

ASSA ABLOY



**C - Protection Plates and Devices
from Rockwood**

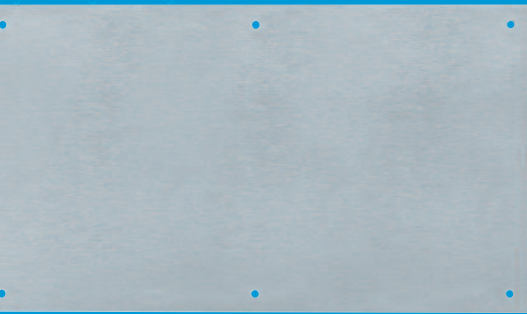

*Protection Plates
and Devices*

UL and W-H Listed

Beautiful Finishes

Self-drilling TEK Screws

ASSA ABLOY, the global leader
in door opening solutions

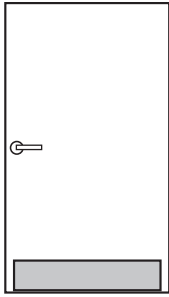

Mop Plate
Up to 6"h x 48"w

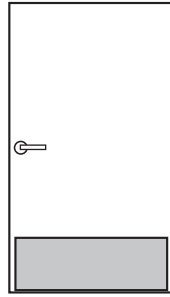

Kick Plate
6" to 12"h x 48"w

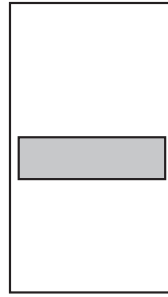

Stretcher Plate
6" to 12"h and up to 48"w

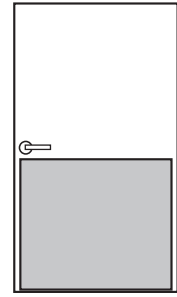

Armor Plate
Up to 48"h x 48"w and available in most finishes



Width of Plates:

Push Side: 2" less than door width. Pull Side: 1½" less than door width.

NFPA 80 STANDARDS — 2-4.5 Protection Plates: Factory-installed protection plates shall be installed in accordance with the listing of the door. Field-installed protection plates shall be labeled and installed in accordance with their listing.

Exception: Labeling is not required where the top of the protection plate is not more than 16 in. (406 mm) above the bottom of the door.

OPTIONAL
Self-Drilling TEK Screws
Cuts Door Plate Installation Time in Half

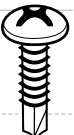

Metal Door Plate - Economy Duty
No. K1038

Material: .038" Aluminum, Stainless Steel

Finishes: Brass Look Aluminum (BRS LK), US32D, and US3**LIFETIME**

Fastener: #6 x 5/8 OH SMS

Ordering: Specify height x width x finish code. Add any options.

Weight: 8" x 34" = 3.2 lbs.

- Options:**
- SA - self-adhesive mounting
 - TORX - security torx screws
 - Cutouts for locks, louvers, or windows (see worksheets on pages C14-C15 for details on how to order).
 - Cutouts for locks, louvers, or windows
 - TEK - self-drilling screws

Metal Door Plate - Standard Duty
No. K1050, K1050F

Material: .050" Aluminum, Brass, Bronze, Stainless Steel

Finishes: Available in standard architectural finishes, US32D**M5**, US32D**316**, and US32**316** (see page 7).

Fastener: #6 x 5/8 OH SMS

Ordering: Specify height x width x finish code. Add any options.

Weight: 8" x 34" = 4.0 lbs.

ANSI: J101 - metal armor plate, J102 - metal kick plate, J103 - metal stretcher & mop plate.

- Options:**
- SA - self-adhesive mounting
 - TEK - self-drilling screws
 - Beveled 3 or 4 edges, specify B3E or B4E
 - Cutouts for locks, louvers, or windows (see worksheets on pages C14-C15 for details on how to order).
 - CSK - countersunk holes
 - Cutouts for locks, louvers, or windows
 - TORX - security torx screws
-  Screw mounting (K1050F) and UL listed for use on 90-minute label wood doors and 3-hour label metal doors.

**Shaped Metal Door Plates - Standard Duty
No. K1050-1 thru K1050-8**

Material: .050" Stainless Steel

Finishes: US32, US32D, US32DMS

Fastener: #6 x 5/8 OH SMS

Ordering: Specify height x width x finish code. Add any options.

Weight: 8" x 34" = 4.0 lbs.

ANSI: J101 - metal armor plate, J102 - metal kick plate, J103 - metal stretcher & mop plate.

- Options:**
- TEK - self-drilling screws.
 - CSK - countersunk holes.
 - Cutouts for locks, louvers, or windows (see worksheets on pages C14-C15 for details on how to order).
 - TORX - security torx screws.
 - Screw mounting (K1050F) and UL listed for use on 90-minute label wood doors and 3-hour label metal doors.
 - Any design is possible. Submit your drawings for a custom quote.

No. K1050-1

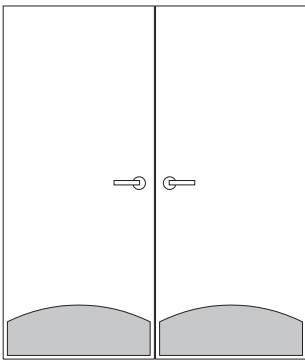

No. K1050-2

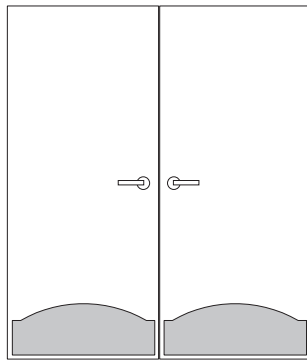

No. K1050-3

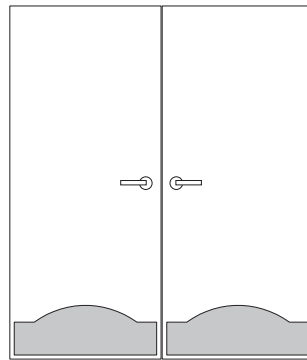

No. K1050-4

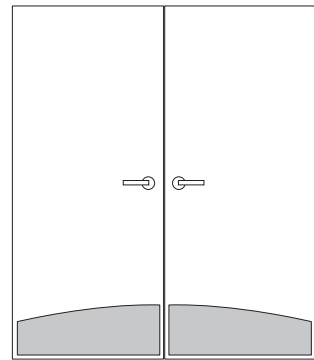

No. K1050-5

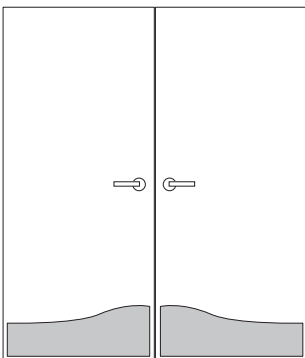

No. K1050-6

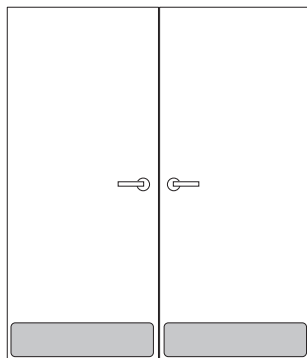

No. K1050-7

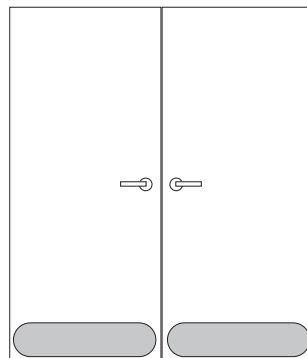

No. K1050-8

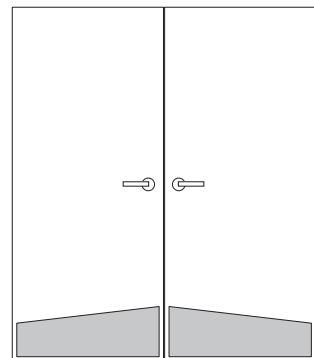

**Shaped Metal Armor Plates - Standard Duty
No. K1050A-1 thru K1050A-8**

Material: .050" Stainless Steel

Finishes: US32, US32D, US32DMS

Fastener: #6 x 5/8 OH SMS

Ordering: Specify height x width x finish code. Add any options.

Weight: 36" x 34" = 18 lbs.

ANSI: J101 - metal armor plate, J102 - metal kick plate, J103 - metal stretcher & mop plate.

- Options:**
- TEK - self-drilling screws.
 - CSK - countersunk holes.
 - Cutouts for locks, louvers, or windows (see worksheets on pages C14-C15 for details on how to order).
 - TORX - security torx screws.
 - Screw mounting (K1050F) and UL listed for use on 90-minute label wood doors and 3-hour label metal doors.
 - Any design is possible. Submit your drawings for a custom quote.

No. K1050A-1

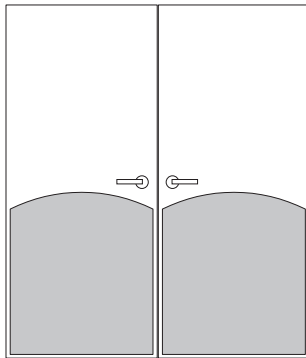

No. K1050A-2

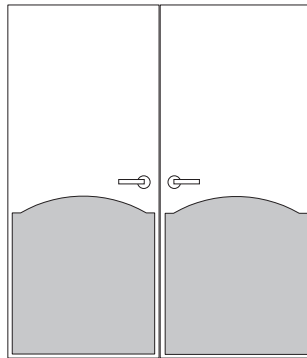

No. K1050A-3

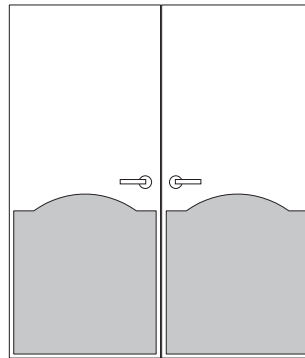

No. K1050A-4

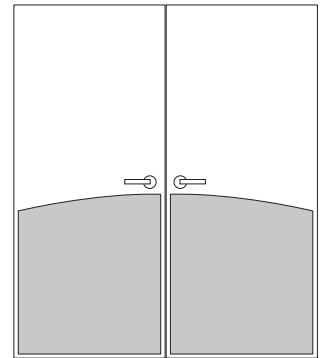

No. K1050A-5

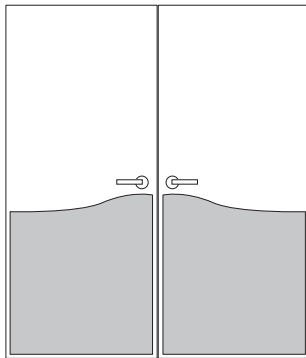

No. K1050A-6

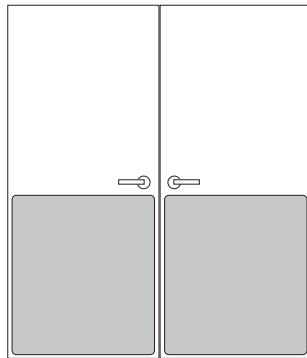

No. K1050A-7

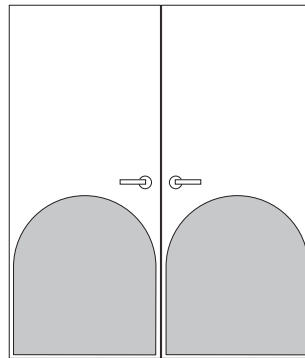

No. K1050A-8

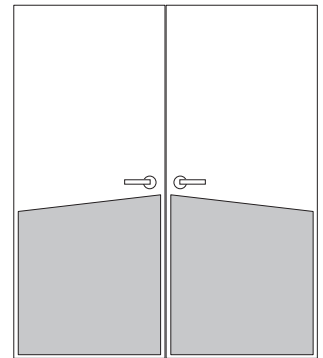

Door Plates

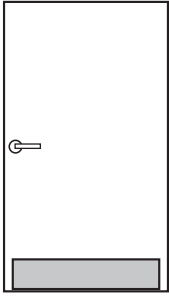

Mop Plate
Up to 6"h x 48"w

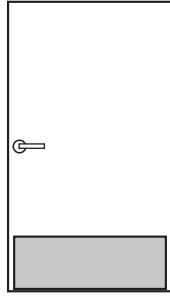

Kick Plate
6" to 12"h x 48"w

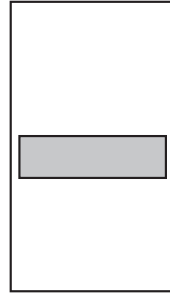

Stretcher Plate
6" to 12"h and up to 48"w

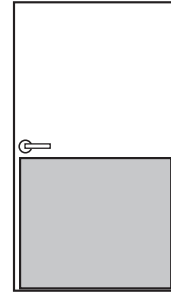

Armor Plate
Up to 48"h x 48"w and available in most finishes

Width of Plates:

Push Side: 2" less than door width. Pull Side: 1½" less than door width.

Metal Door Plate - Heavy Duty
No. K1062

- Material:** .062" Aluminum, Brass, Bronze, Stainless Steel
Finishes: Available in standard architectural finishes (see page 7).
Fastener: #6 x 5/8 OH SMS
Ordering: Specify height x width x finish code. Add any options.
Weight: 8" x 34" = 5.0 lbs.
ANSI: J101 - metal armor plate, J102 - metal kick plate, J103 - metal stretcher & mop plate.
Options:
- TEK - self-drilling screws.
 - CSK - countersunk holes.
 - Beveled 3 or 4 edges, specify B3E or B4E.
 - TORX - security torx screws.
 - Cutouts for locks, louvers, or windows (see worksheets on pages C14-C15 for details on how to order).

Metal Door Plate - Extra Heavy Duty
No. K1125

- Material:** .125" Aluminum, Brass, Bronze, Stainless Steel
Finishes: Available in standard architectural finishes, US32D316 (see page 7).
Fastener: #6 x 5/8 OH SMS
Ordering: Specify height x width x finish code. Add any options.
Weight: 8" x 34" = 10.0 lbs.
ANSI: J101 - metal armor plate, J102 - metal kick plate, J103 - metal stretcher & mop plate.
Options:
- TEK - self-drilling screws.
 - Beveled 3 or 4 edges, specify B3E or B4E (**not applicable on Aluminum Diamond Plate**).
 - Cutouts for locks, louvers, or windows (see worksheets on pages C14-C15 for details on how to order).
 - TORX - security torx screws.

Metal Door Plate - Extra Heavy Duty Diamond Plate
No. K1125 DIA

- Material:** .125" Aluminum
Finishes: Polished Aluminum Diamond Plate (ALM DIA).
Fastener: #6 x 5/8 OH SMS
Ordering: Specify height x width x finish code. Add any options.
Weight: 8" x 34" = 10.0 lbs.
ANSI: J101 - metal armor plate, J102 - metal kick plate, J103 - metal stretcher & mop plate.
Options:
- TEK - self-drilling screws.
 - Cutouts for locks, louvers, or windows (see worksheets on pages C14-C15 for details on how to order).
 - TORX - security torx screws.



ALM DIA
Polished Aluminum Diamond Plate

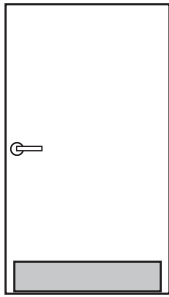

Mop Plate
Up to 6"h x 48"w

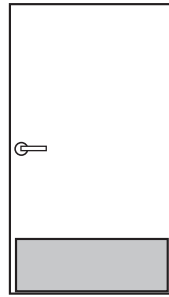

Kick Plate
6" to 12"h x 48"w

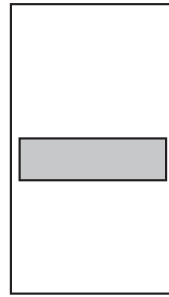

Stretcher Plate
6" to 12"h and up to 48"w

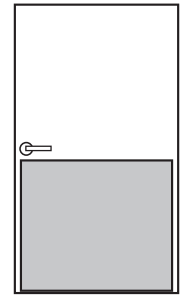

Armor Plate
Up to 48"h x 48"w



Width of Plates:

Push Side: 2" less than door width. Pull Side: 1½" less than door width.

NFPA 80 STANDARDS — 2-4.5 Protection Plates: Factory-installed protection plates shall be installed in accordance with the listing of the door. Field-installed protection plates shall be labeled and installed in accordance with their listing.

Exception: Labeling is not required where the top of the protection plate is not more than 16 in. (406 mm) above the bottom of the door.

**Plastic Door Plate - Heavy Duty
No. K2060**

Material: .060" Kydex® 160 PVC Acrylic Alloy Plastic*

Finishes: Beige #72005, Calcutta Black #52000, Chocolate Brown #72010, Pewter Gray #52001

Fastener: #6 x ¾ TH SMS

Ordering: Specify height x width x color. Add any options.

Weight: 8" x 34" = 1.0 lbs.

ANSI: J105 - plastic armor plate, J106 - plastic kick plate, J107 - plastic stretcher & mop plate.

Optional:

- Cutouts for locks, louvers, or windows (see worksheets on pages C14-C15 for details on how to order).
- SA - self-adhesive mounting (K2060SA).
- SA-F - self-adhesive mounting (K2060SA-F) and UL approved for use of 90-minute wood doors and 3-hour metal doors.

**Plastic Door Plate - Extra Heavy Duty
No. K2125**

Material: .125" Kydex® 160 PVC Acrylic Alloy Plastic*

Finishes: Beige #72005, Calcutta Black #52000, Chocolate Brown #72010, Pewter Gray #52001

Fastener: #6 x ¾ TH SMS

Ordering: Specify height x width x color. Add any options.

Weight: 8" x 34" = 1.8 lbs.

ANSI: J105 - plastic armor plate, J106 - plastic kick plate, J107 - plastic stretcher & mop plate.

Optional:

- Cutouts for locks, louvers, or windows (see worksheets on pages C14-C15 for details on how to order).
- CSK - countersunk holes.

* Kydex 160 meets Class 1A building code ratings up to .060" thick.

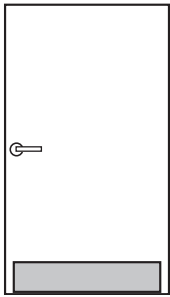

Mop Plate
Up to 6"h x 48"w

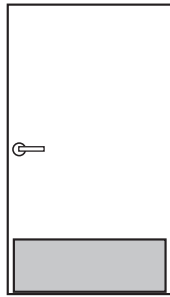

Kick Plate
6" to 12"h x 48"w

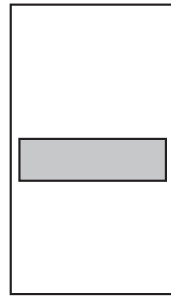

Stretcher Plate
6" to 12"h and up to 48"w

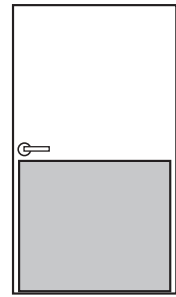

Armor Plate
Up to 48"h x 48"w

Width of Plates:

Push Side: 2" less than door width. Pull Side: 1½" less than door width.

Laminate Plastic Door Plate
No. K3125

Material: .125" Laminate Plastic

Finishes: Beige, Black, Brown, Pewter Gray, White

Fastener: #6 x ¾ TH SMS

Ordering: Specify height x width x finish code x color. Add any options.

Weight: 8" x 34" = 1.8 lbs.

ANSI: J105 - plastic armor plate, J106 - plastic kick plate, J107 - plastic stretcher & mop plate.

- Optional:**
- SA - self-adhesive mounting (K3125SA).
 - Cutouts for locks, louvers, or windows (see worksheets on pages C14-C15 for details on how to order).
 - CSK - countersunk holes.

Clear Plastic Door Plate
No. K4125

Material: .125" Clear Plastic

Finishes: Clear

Fastener: #6 x ¾ TH SMS

Ordering: Specify height x width. Add any options.

Weight: 8" x 34" = 1.5 lbs.

ANSI: J105 - plastic armor plate, J106 - plastic kick plate, J107 - plastic stretcher & mop plate.

- Optional:**
- Cutouts for locks, louvers, or windows (see worksheets on pages C14-C15 for details on how to order).
 - CSK - countersunk holes.

Features: Break and scratch resistant.

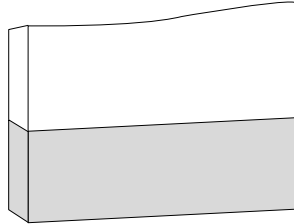

**One-Sided Angle Plate
No. KB1150**

Material: .050" Aluminum, Brass, Bronze, or Stainless Steel

Finishes: Available in standard architectural finishes (see page 7).

Fastener: #6 x 5/8 FH SMS

Ordering: Provide drawing specifying size, and square or bevel edge door.

Optional: Beveling, TORX - security torx screws and TEK - self-drilling screws, cutouts for hinges, flush bolts, and locks.

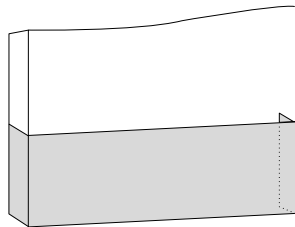

**Two-Sided Angle Plate
No. KB1151**

Material: .050" Aluminum, Brass, Bronze, or Stainless Steel

Finishes: Available in standard architectural finishes (see page 7).

Fastener: #6 x 5/8 FH SMS

Ordering: Provide drawing specifying size, and square or bevel edge door.

Optional: Beveling, TORX - security torx screws and TEK - self-drilling screws, cutouts for hinges, flush bolts, and locks.

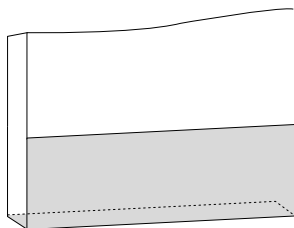

**Bottom Angle Plate
No. KB1152**

Material: .050" Aluminum, Brass, Bronze, or Stainless Steel

Finishes: Available in standard architectural finishes (see page 7).

Fastener: #6 x 5/8 FH SMS

Ordering: Provide drawing specifying size, and square or bevel edge door.

Optional: Beveling, TORX - security torx screws and TEK - self-drilling screws.

Mortise Door Edges
No. 300, 301, 302, 302B

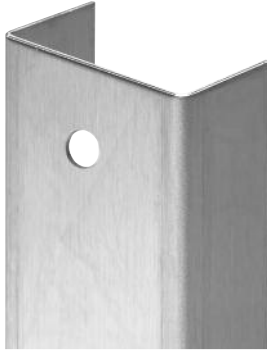

- Material:** .050" Brass, Bronze, Prime Coated Steel, Stainless Steel
- Finishes:** Available in standard architectural finishes, US32D**MS**, US32D**316**, prime painted steel (see page 7).
- Fastener:** #6 x 5/8" FH SMS
- Ordering:** Specify any length up to 96" (standard lengths are 42", 84", 96").
NOTE: 84" and 96" are made to match net door height - specify.
- Options:**
- UL fire rated listed for stainless steel, brass and bronze. For use on wood or plastic faced fire doors rated up to and including 1½ hours or hollow metal, steel covered, composite type fire doors rated up to and including 3 hours. Specify UL when ordering (300-UL).
 - Cutouts for flush bolts, lock strikes, locks, and hinges (see worksheets on pages C10-C11 or C13-C15 for details on how to order).
- Features:** Door edges are sized to be mortised into the surface of 1¾" thick wood doors. Advise if your door is another thickness. **NOTE:** Some wood doors that are nominally 1¾" vary significantly.

NOTE: Your door thickness is a nominal dimension. Doors can vary + or - 1/16" from the nominal dimension. When ordering, verify actual door thickness to assure a working fit of the door edge.

No. 300
ANSI 156.6 - J204

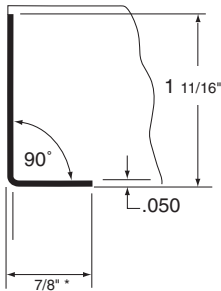

No. 301
ANSI 156.6 - J205

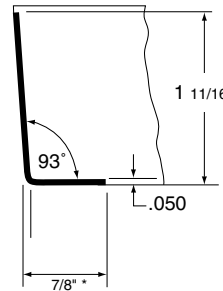

No. 302
ANSI 156.6 - J210

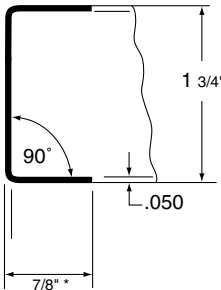

No. 302B
ANSI 156.6 - J211

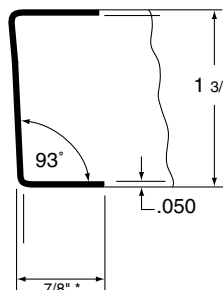

* Modified leg lengths available.

Non-Mortise Door Edges

No. 304, 305, 306, 306-AST, 306B, 306B-AST, 307



NOTE: Your door thickness is a nominal dimension. Doors can vary + or - 1/16" from the nominal dimension. When ordering, verify actual door thickness to assure a working fit of the door edge.

Material: .050" Brass, Bronze, Plain Steel, Stainless Steel

Finishes: Available in standard architectural finishes, US32DMS, US32D316, prime painted steel (see page 7).

Fastener: #6 x 5/8 FH SMS

Ordering: Specify any length up to 96" (standard lengths are 42", 84", 96").

NOTE: 84" and 96" are made to match net door height - specify. Specify wood or metal door.

- Options:**
- UL fire rated listed for stainless steel, brass and bronze. For use on wood or plastic faced fire doors rated up to and including 1½ hours or hollow metal, steel covered, composite type fire doors rated up to and including 3 hours. Specify UL when ordering (306-UL).
 - Cutouts for flush bolts, lock strikes, locks, and hinges (see worksheets on pages C10-C11 or C13-C15 for details on how to order).

- Features:**
- Door edges are sized for 1¾" thick wood or metal doors. Advise if your door is another thickness. **NOTE:** Some wood doors that are nominally 1¾" vary significantly.
 - 306-AST and 306B-AST include an astragal, providing additional protection against vandalism.

No. 304

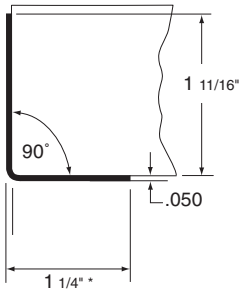

No. 305

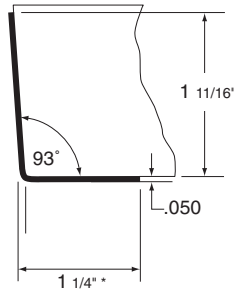

No. 306

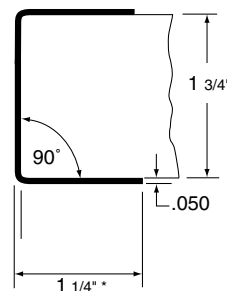

**No. 306-AST
(with Astragal)**

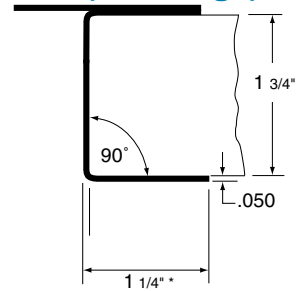

No. 306B

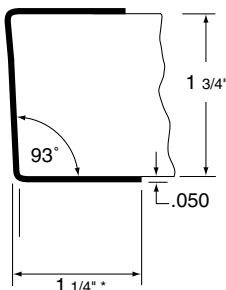

**No. 306B-AST
(with Astragal)**

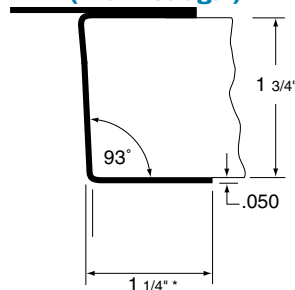

No. 307

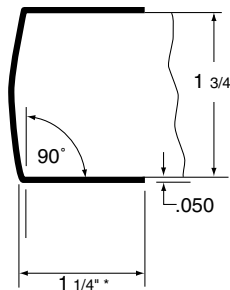

* Modified leg lengths available.

Hinge Side Door Edge Order Form

Fill out this form and email / fax form to info@rockwoodmfg.com / 800-922-9212.

Customer Information

Contact Name: _____	Date: _____
Company Name: _____	Account #: _____
Address: _____	Phone #/Fax #: _____
City/State/Zip: _____	Email: _____

Select a Cutout

Mortised <input type="checkbox"/> 300	<input type="checkbox"/> 301	<input type="checkbox"/> 302	<input type="checkbox"/> 302B
Non-Mortised <input type="checkbox"/> 304	<input type="checkbox"/> 305	<input type="checkbox"/> 306	<input type="checkbox"/> 306B



Quantity: _____

Tag. Nos.: _____

Handing: _____

Other _____

Select Hinge Size, Door Type and Fill in Dimensions

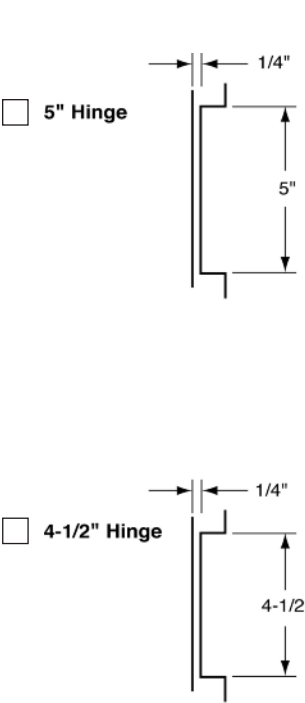

Door with 3 Hinges

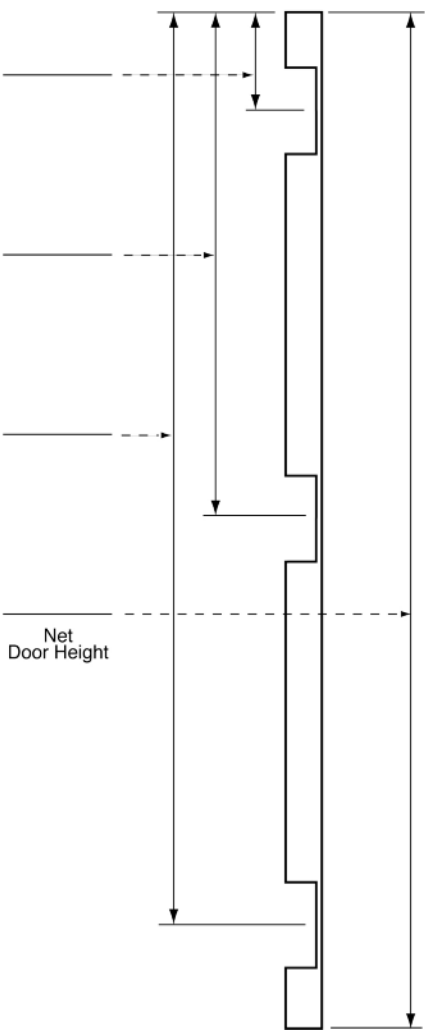

Door with 4 Hinges

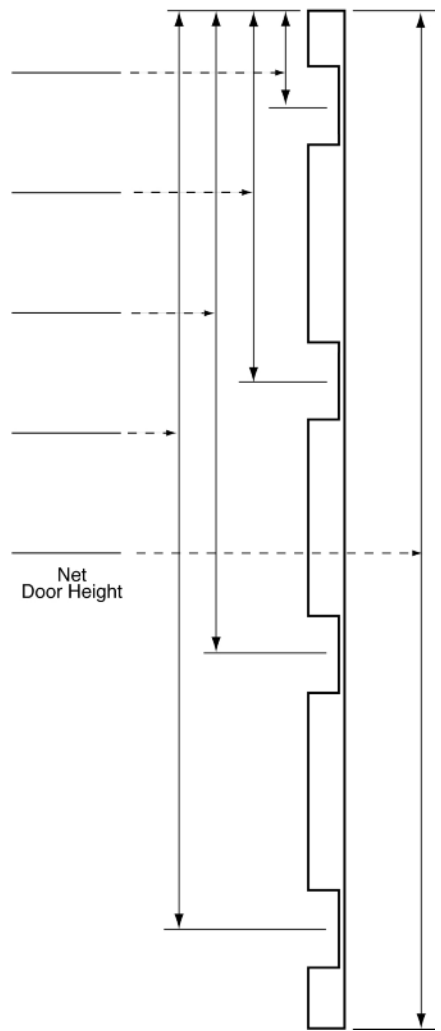

NOTE: Your door thickness is a nominal dimension. Doors can vary + or - 1/16" from the nominal dimension. When ordering, verify actual door thickness to assure a working fit of the door edge.

Lock Side Door Edge Order Form

Fill out this form and email / fax form to info@rockwoodmfg.com / 800-922-9212.

Customer Information

Contact Name: _____ Date: _____
 Company Name: _____ Account #: _____
 Address: _____ Phone #/Fax #: _____
 City/State/Zip: _____ Email: _____

Select a Door Edge

Mortised 300 301 302 302B
 Non-Mortised 304 305 306 306-AST 306B 306B-AST

Quantity: _____
 Tag. Nos.: _____
 Handing: _____



Other _____

Select Cutout, Door Type and Fill in Dimensions

161 Latch Bolt

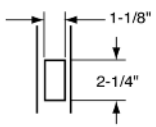

86 Mortise Lock

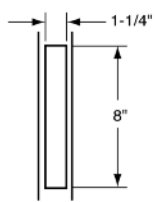

ASA Strike

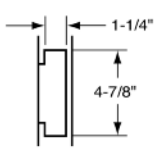

Cylindrical Strike

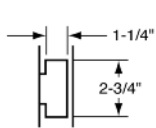

Manual Flush Bolt

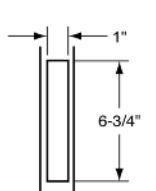

Automatic Flush Bolt

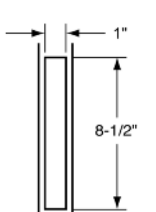

Metal Door

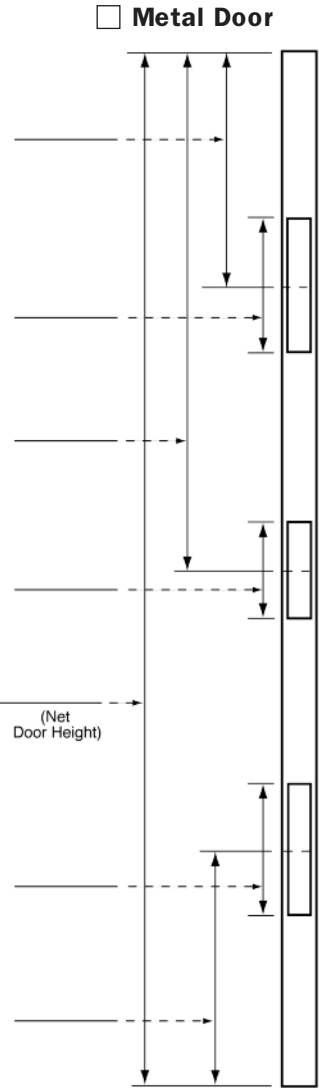

Wood Door

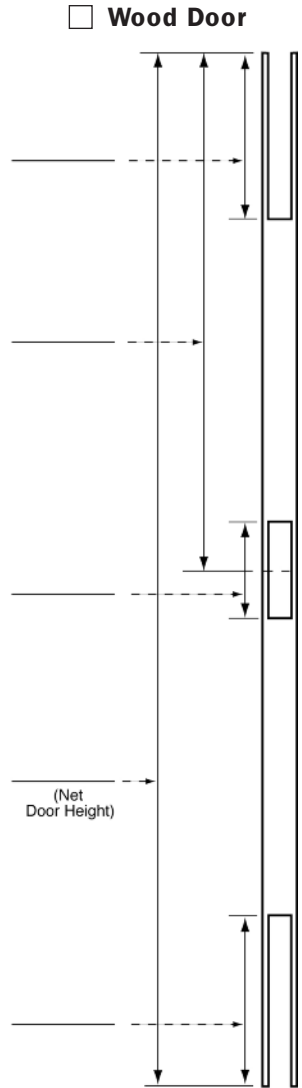

Overlapping Door Edges
No. 308, 309, 310, 310S, 310B, 310BS



- Material:** .050" Brass, Bronze, Prime Coated Steel, Stainless Steel
- Finishes:** Available in standard architectural finishes, US32D**MS**, US32D**316**, prime painted steel (see page 7).
- Fastener:** #6 x 5/8 FH SMS
- Ordering:** Specify any length (standard length is 42"). Specify wood or metal door.
- Options:**
- UL fire rated listed for stainless steel, brass and bronze. For use on wood or plastic faced fire doors rated up to and including 1½ hours or hollow metal, steel covered, composite type fire doors rated up to and including 3 hours. Specify UL when ordering (310-UL).
 - Cutouts for flush bolts, lock strikes, locks, and hinges (see worksheets on pages C10-C11 or C13-C15 for details on how to order).

NOTE: Your door thickness is a nominal dimension. Doors can vary + or - 1/16" from the nominal dimension. When ordering, verify actual door thickness to assure a working fit of the door edge.

No. 308

ANSI 156.6 - J201

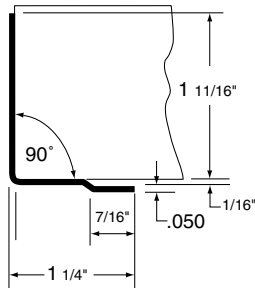

No. 309

ANSI 156.6 - J202

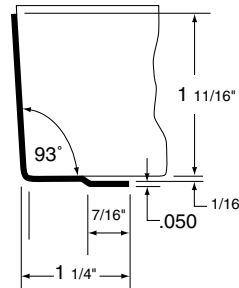

No. 310

ANSI 156.6 - J207

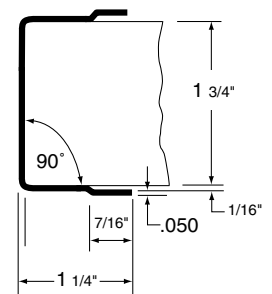

**No. 310S
(single side)**

ANSI 156.6 - J207

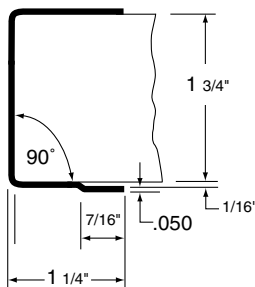

No. 310B

ANSI 156.6 - J208

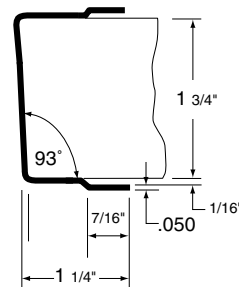

**No. 310BS
(single side)**

ANSI 156.6 - J208

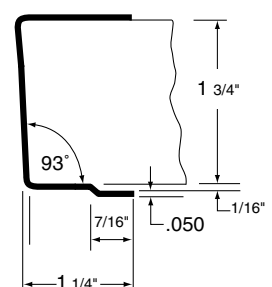

Ordering Instructions

The use of door edges and armor plates not only offers superior protection to expensive doors, it also adds an attractive and functional finishing touch. Armor plates and door edges are available in all architectural finishes. The following 2 pages are intended to help you determine the cutout locations required on armor plates and door edges. Follow the steps listed to assure complete consideration of all factors concerning cutout locations.

1. Determine the armor plate height. We recommend 48" high. If you cut holes for lock, make the armor plate high enough to provide at least 1/2" from edge of the top cutout to the top edge of the plate, or 1/2" above the top of the lock front when mortise lock is used. This prevents a cutout running out of the top edge of the plate.
2. Determine the armor plate width. Armor plates are usually mounted on the stop or push side of the door. Measure the net width of the door face and subtract the following depending on the type of door edges you specify:
 - a) non-mortise door edges = 2 5/8" (for 1/8" gap)
 - b) overlapping door edges = 2" (for 3/16" overlap)
 - c) no door edges - single door = 1 1/4"
 - d) no door edges - pairs of doors = 1" (without mullions)
3. List all hardware that will be mounted on the door. Identify those items that will require armor plate and/or door edge cutouts; i.e., lock spindle, cylinder, thumb piece, lock front and strike, flush bolts, hinges, louvers, lites.
4. Determine door undercut and location of armor plate and door edge to bottom of the door. We recommend mounting plates flush with the bottom of the door.
5. Determine location of all hardware cutout centerlines from the bottom of the armor plate.
6. Determine the backset of lock cutouts on the armor plate.

		Square Edge	Bevel Edge
a) with non-mortise door edges	lock backset minus	1 5/16"	1 3/8"
b) with overlapping door edges	lock backset minus	1"	1 1/16"
c) without door edges - single doors	lock backset minus	5/8"	1 1/16"
d) without door edges - pair of doors (without mullions)	lock backset minus	3/8"	7/16"

7. Specify the size of cutouts.
8. Determine the hand of the door. Armor plates are typically mounted on the stop or push side of the door. Function holes must be given special attention as they may not be required on reverse bevel doors.

NOTE: Your door thickness is a nominal dimension. Doors can vary + or - 1/16" from the nominal dimension. When ordering, verify actual door thickness to assure a working fit of the door edge.

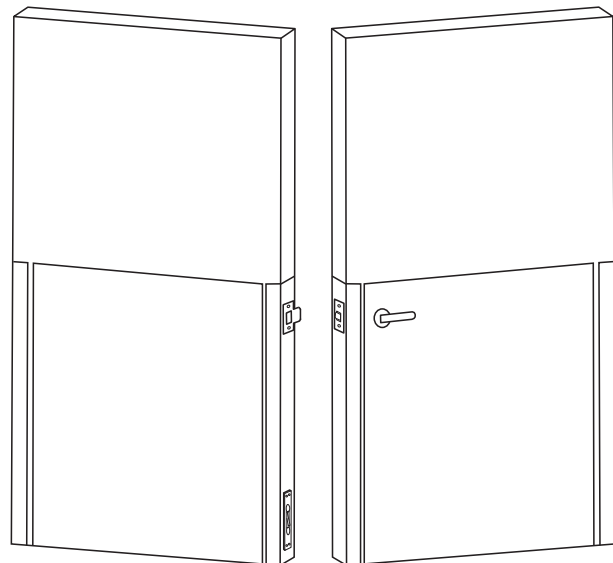

Cutouts

This drawing shows typical location of cutouts on armor plates and door edges. It also illustrates non-mortise door edges, but this can be used as a guide for armor plates with overlapping door edges or no door edges. Use this as a worksheet to make your own drawings or photocopy and fill in your dimensions.

For Hinge Cutouts: Be sure to allow for door undercut and location of edge on door if other than flush with bottom.

For Lock Trim Protection: Consider using a trim protector bar (see pages C16-C20).

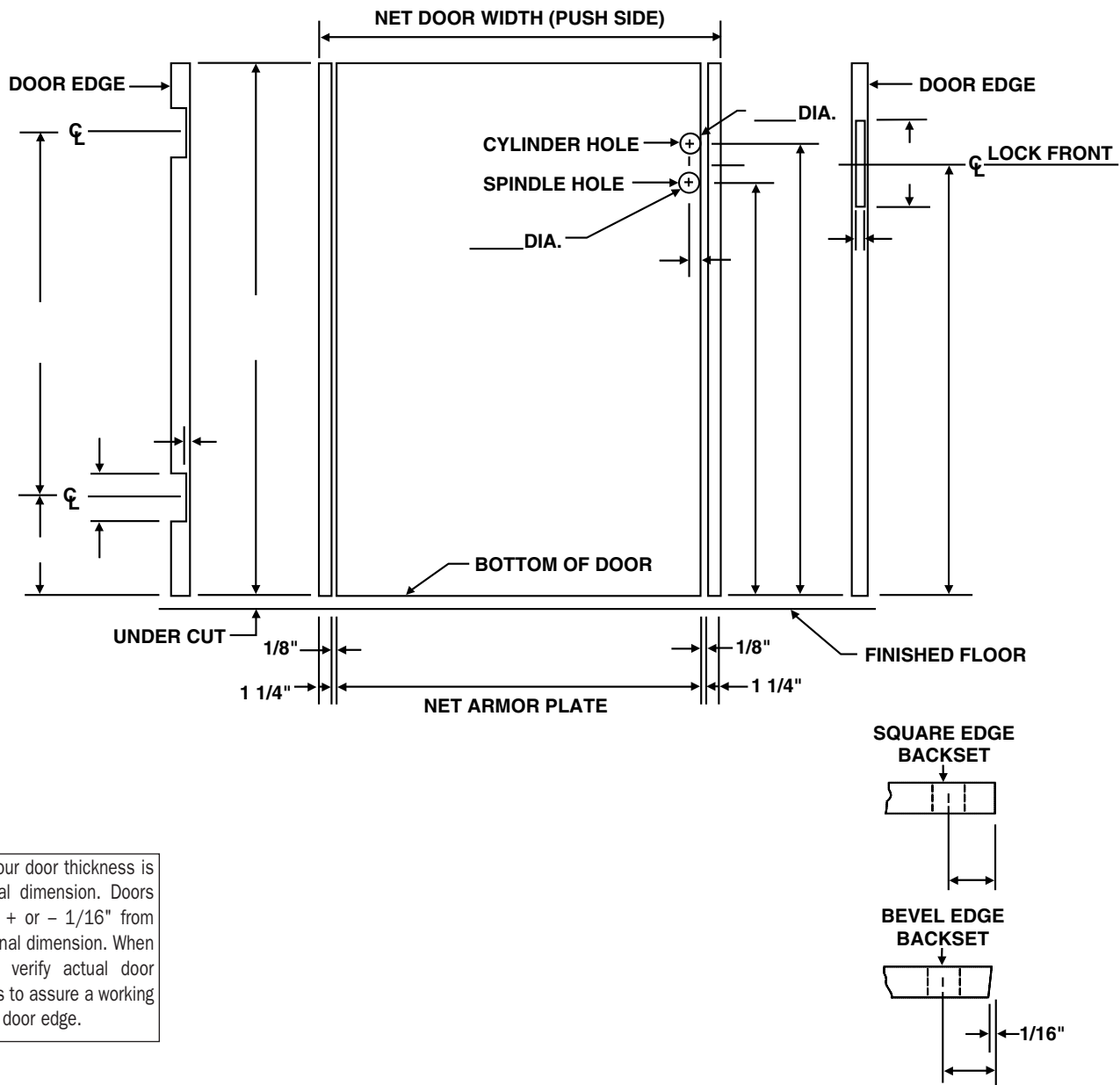

NOTE: Your door thickness is a nominal dimension. Doors can vary + or - 1/16" from the nominal dimension. When ordering, verify actual door thickness to assure a working fit of the door edge.

Cutouts

This drawing shows typical location of cutouts on armor plates and door edges. It also illustrates non-mortise door edges, but this can be used as a guide for armor plates with overlapping door edges or no door edges. Use this as a worksheet to make your own drawings or photocopy and fill in your dimensions.

For Hinge Cutouts: Be sure to allow for door undercut and location of edge on door if other than flush with bottom.

For Lock Trim Protection: Consider using a trim protector bar (see pages C16-C20).

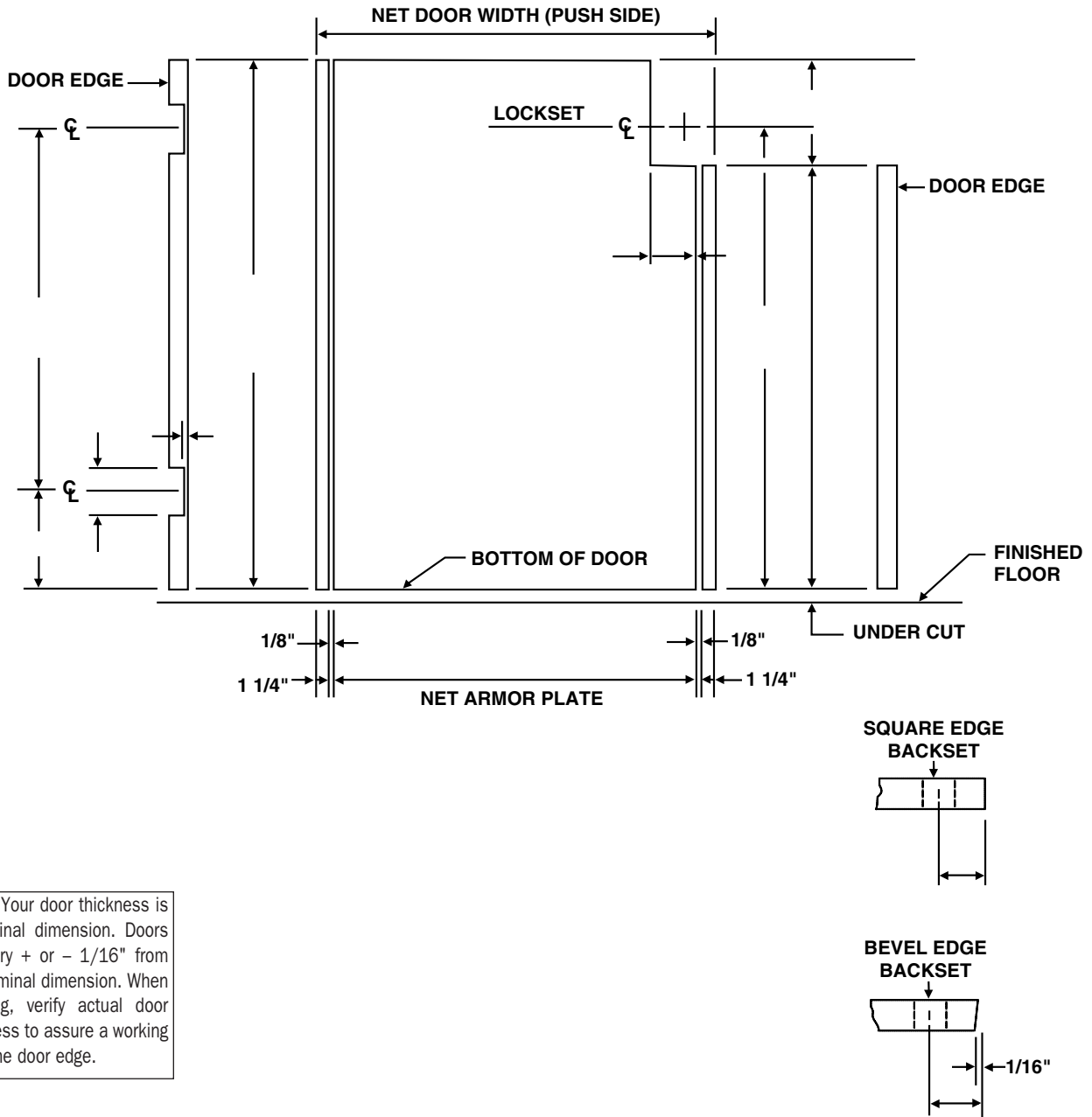

NOTE: Your door thickness is a nominal dimension. Doors can vary + or - 1/16" from the nominal dimension. When ordering, verify actual door thickness to assure a working fit of the door edge.

Solutions to Door and Trim Damage

Damage to doors and door trim (exit devices, knobs, levers, etc.) from hallway traffic such as carts and gurneys cost hospitals, schools and other institutions tens of thousands of dollars every year. The following 4 pages are Rockwood Manufacturing's line of **Unique, Patented Protection Products designed to prevent this damage**. Made from solid stainless steel the line is engineered to **deflect** traffic safely away from the door or trim.

Our line of trim protector bars is designed to safely deflect traffic away from exit devices, door knobs/levers, or other trim. These bars are made from solid stainless steel and are available in both **standard duty** ($\frac{3}{16}$ inch) and **heavy duty** ($\frac{3}{8}$ inch) versions. The bars are mounted either directly below, over, or in front of the trim depending on the application. They are available in a variety of projections and center to centers to fit your needs. If you require custom designs our engineering department can work with you to meet your needs.

Choosing the correct protection bar:

1. **Determine traffic** - light to moderate use = SD Series, heavy use = HD Series
2. **Measure projections** - of exit device, door knob, etc.
3. **Review product dimensions** - to match bar to your specific needs.

WARNING: Do not locate protection bars where they can impede operation of exit devices.

How They Work

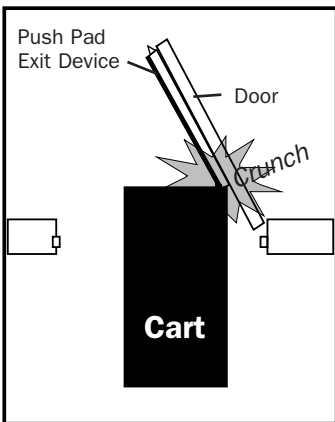

Without Bar - Costly Damage

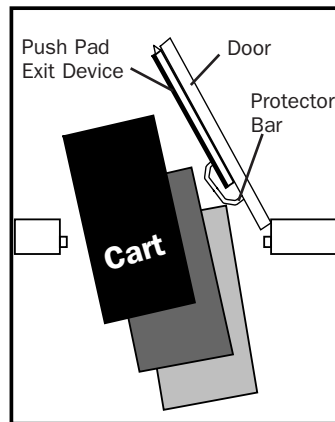

With Bar - Safely Deflected Away

Trim Protector Bars

Heavy Duty Application

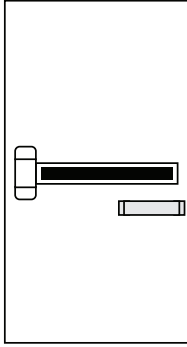

Application shown for product
HD2230, HD2240, HD2250

* Advise if door thickness is other than 1 3/4".



patent no.
5,934,023

**Heavy Duty Protector Bars
HD2230, HD2230M**

Material: Stainless Steel

Finishes: US32D

Fastener: 1/4"-20 x 2 1/4" Thru Bolt & Finish Washer (standard 1 3/4" door*).

Other: Made to order sizes available.

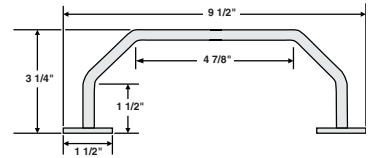

No.	CTC	Material Size	Projection	Weight
HD2230	8"	3/8" x 1 1/2"	3 3/4"	2.3 lbs.
HD2230M	specify	3/8" x 1 1/2"	3 3/4"	—



patent no.
5,934,023

**Heavy Duty Protector Bars
HD2240, HD2240M**

Material: Stainless Steel

Finishes: US32D

Fastener: 1/4"-20 x 2 1/4" Thru Bolt & Finish Washer (standard 1 3/4" door*).

Other: Made to order sizes available.

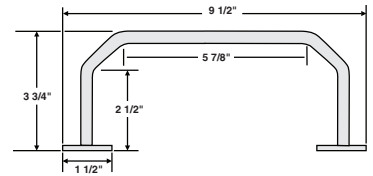

No.	CTC	Material Size	Projection	Weight
HD2240	8"	3/8" x 1 1/2"	3 3/4"	2.5 lbs.
HD2240M	specify	3/8" x 1 1/2"	3 3/4"	—



patent no.
5,934,023

**Heavy Duty Protector Bars
HD2250, HD2250M**

Material: Stainless Steel

Finishes: US32D

Fastener: 1/4"-20 x 2 1/4" Thru Bolt & Finish Washer (standard 1 3/4" door*).

Other: Made to order sizes available.

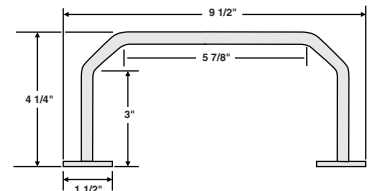

No.	CTC	Material Size	Projection	Weight
HD2250	8"	3/8" x 1 1/2"	4 1/4"	2.7 lbs.
HD2250M	specify	3/8" x 1 1/2"	4 1/4"	—

Trim Protector Bars

Standard Duty Applications

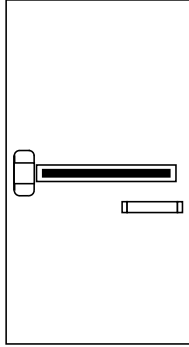

Application shown for product SD1230, SD1240, SD1250

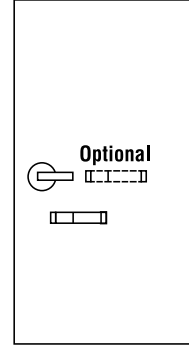

Application shown for product SD1260



patent no. 5,934,023

Standard Duty Protector Bar No. SD1230

Material: Stainless Steel
Finishes: US32D
Fastener: #10-24 x 1 FHMS and Sex Bolt

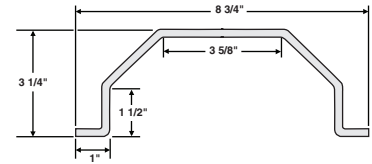

No.	CTC	Material Size	Projection	Weight
SD1230	8"	3/16" x 2"	3 3/4"	1.4 lbs.



patent no. 5,934,023

Standard Duty Protector Bar No. SD1240

Material: Stainless Steel
Finishes: US32D
Fastener: #10-24 x 1 FHMS and Sex Bolt

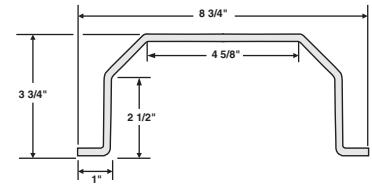

No.	CTC	Material Size	Projection	Weight
SD1240	8"	3/16" x 2"	3 3/4"	1.6 lbs.



patent no. 5,934,023

Standard Duty Protector Bar No. SD1250

Material: Stainless Steel
Finishes: US32D
Fastener: #10-24 x 1 FHMS and Sex Bolt

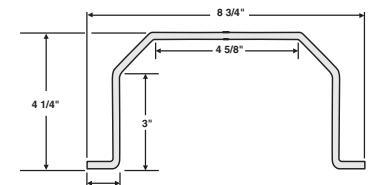

No.	CTC	Material Size	Projection	Weight
SD1250	8"	3/16" x 2"	4 1/4"	1.7 lbs.



Standard Duty Protector Bar No. SD1260

Material: Stainless Steel
Finishes: US32D
Fastener: #10-24 x 1 FHMS and Sex Bolt

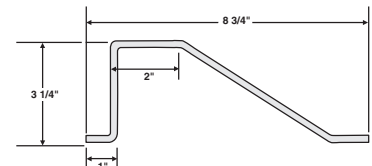

No.	CTC	Material Size	Projection	Weight
SD1260	8"	3/16" x 2"	3 3/4"	1.6 lbs.

Trim Protector Bars

Applications

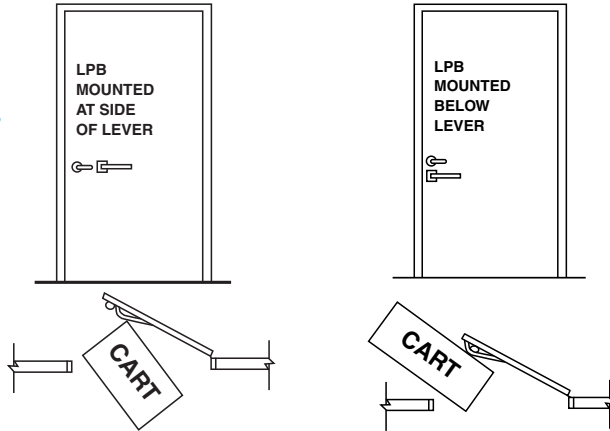

Application shown for product R101LPB thru R115LPB

* Advise if door thickness is other than 1 3/4".

**Trim Protector Bars
No. R101LPB, R102LPB**

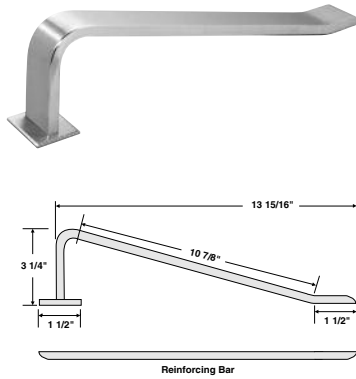

- Material:** Brass, Bronze, Stainless Steel
- Finishes:** Available in standard architectural finishes (see page 7).
- Fastener:** 1/4-20 x 2 1/4 Thru Bolt, 1/4-20 x 2 Thru Bolt, Finish Washers (standard 1 3/4" door*).
- Other:** Made to order sizes available.

No.	CTC	Material Size	Weight
R101LPB	12"	3/8" x 1 1/2"	2.6 lbs.
R102LPB (with reinforcing bar)	12"	3/8" x 1 1/2"	4.6 lbs.

**Trim Protector Bars — Lever Handle
No. R111LPB, R112LPB**

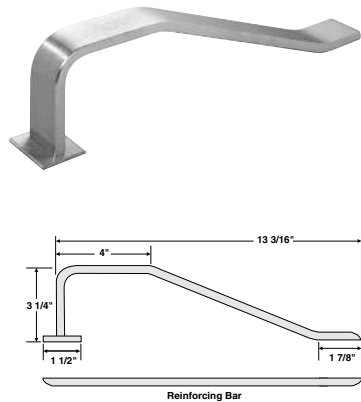

- Material:** Brass, Bronze, Stainless Steel
- Finishes:** Available in standard architectural finishes (see page 7).
- Fastener:** 1/4-20 x 2 1/4 Thru Bolt, 1/4-20 x 2 Thru Bolt, Finish Washers (standard 1 3/4" door*).
- Other:** Made to order sizes available.

No.	CTC	Material Size	Weight
R111LPB	12"	3/8" x 1 1/2"	2.6 lbs.
R112LPB (with reinforcing bar)	12"	3/8" x 1 1/2"	4.6 lbs.

**Trim Protector Bar — Long Lever Handle
No. R115LPB**

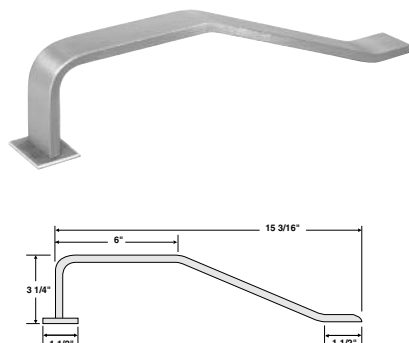

- Material:** Brass, Bronze, Stainless Steel
- Finishes:** Available in standard architectural finishes (see page 7).
- Fastener:** 1/4-20 x 2 1/4 Thru Bolt, 1/4-20 x 2 Thru Bolt, Finish Washers (standard 1 3/4" door*).
- Other:** Made to order sizes available.

No.	CTC	Material Size	Weight
R115LPB	14"	3/8" x 1 1/2"	3.0 lbs.

Exit Device Protector

EDP Application

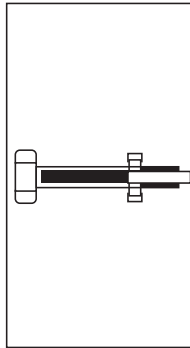

Application shown for product R116EDPL and R116EDPH. Field cutting hinge end of exit device is required.

* Advise if door thickness is other than 1 3/4".

**Exit Device Protector
 No. R116EDPL**

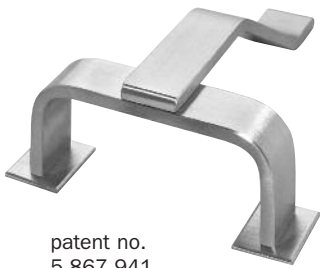

patent no.
 5,867,941

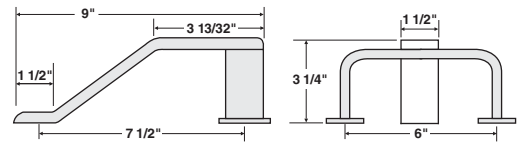

Material: Stainless Steel

Finishes: US32D

Fastener: 2 ea. 1/4-20 x 2 1/4 Thru Bolts, 1 ea. 1/4-20 x 2 Thru Bolt, Finish Washers (standard 1 3/4" door*).

Features: Suitable for use with exit devices that project less than 2 3/8" from door face; i.e., Sargent® 80 series, Monarch® 17 series, and Precision® Apex series.

No.	Material Size	Projection	Weight
R116EDPL	3/8" x 1 1/2"	3 1/4"	3.5 lbs.

© Sargent 80 series is a registered trademark of SARGENT Manufacturing Company.
 © Monarch 17 series is a registered trademark of Ingersoll-Rand Company.
 © Precision Apex series is a registered trademark of Apex Machine Tool Company.

**Exit Device Protector
 No. R116EDPH**

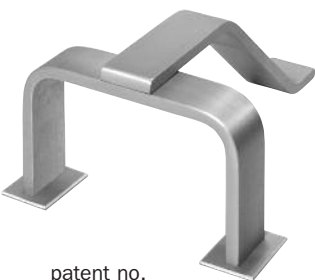

patent no.
 5,867,941

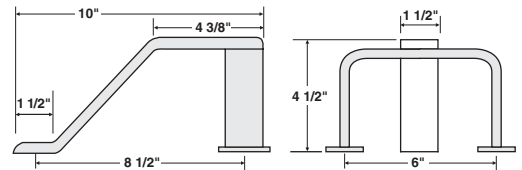

Material: Stainless Steel

Finishes: US32D

Fastener: 2 ea. 1/4-20 x 2 1/4 Thru Bolts, 1 ea. 1/4-20 x 2 Thru Bolt, Finish Washers (standard 1 3/4" door*).

Features: Suitable for use with exit devices that project less than 3 5/8" from door face; i.e., Von Duprin® 33, 98 and 99 series, Yale® 7000 series, Corbin Russwin® ED500 series.

No.	Material Size	Projection	Weight
R116EDPH	3/8" x 1 1/2"	4 1/2"	3.7 lbs.

© VonDuprin 33, 98, and 99 series is a registered trademark of Ingersoll-Rand Company.
 © Yale 7000 series is a registered trademark of Yale Security Group.
 © Corbin Russwin ED500 series is a registered trademark of Corbin Russwin, Inc.

Vertical Rod/Latch Guard Covers

Vertical Rod Cover

The vertical rod cover (BFRC) is a sturdy channel made of .050" stainless steel (other finishes available) designed to fit over the vertical rod, protecting it from damage caused by carts, gurneys, etc. It is available in 12" and 24" lengths. Mounting is with sheet metal screws.

Latch Guard Cover

The latch guard cover (BFLG) is made of .062" material and is designed with a 45° ramp which when placed over the latch at the base of the door deflects traffic safely away. It meets ADA requirements for a "smooth bottom door surface". The BFLG is available in 10", 12", and 16" lengths and most architectural finishes. Machine screws are provided.

Application

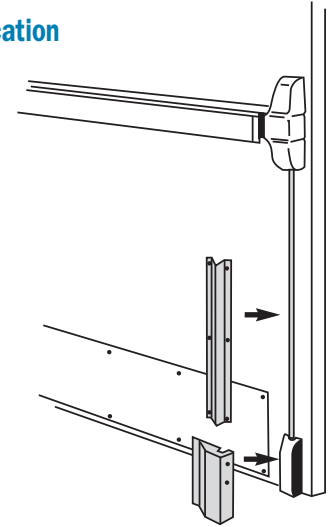

Application shown for products BFRC and BFLG. Protects vertical rod and latch of exit device. Meets ADA "smooth surface" requirements.



**Vertical Rod Covers
No. BFRC12, BFRC24**

- Material:** .050" Brass, Bronze, Stainless Steel
- Finishes:** Available in standard architectural finishes (see page 7).
- Fastener:** #6 x 5/8" OH SMS
- Optional:** Made to order sizes available.

No.	Height	Width	Projection	Weight
BFRC12	12"	3 1/4"	1 5/8"	0.9 lbs.
BFRC24	24"	3 1/4"	1 5/8"	1.8 lbs.

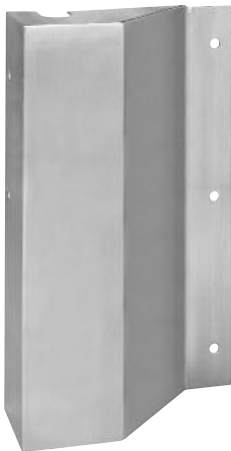

**Latch Guard Covers
No. BFLG10, BFLG12, BFLG16**

- Material:** .062" Brass, Bronze, Stainless Steel
- Finishes:** Available in standard architectural finishes (see page 7).
- Fastener:** 8-32 x 3/4" OHMS; WS available on request.
- Ordering:** Specify handing.
- Optional:** Made to order sizes available.

No.	Height	Width	Projection	Weight
BFLG10	10"	6"	2 3/8"	1.6 lbs.
BFLG12	12"	6"	2 3/8"	1.9 lbs.
BFLG16	16"	6"	2 3/8"	2.5 lbs.

Rockwood manufactures custom strikes to your specifications in almost any size, shape and finish. The drawings below represent standard ASA and T strikes. For easy and efficient ordering, please use the order form on the next page and fill in your requirements on drawing(s) and chart then fax or email us the form.

NOTE: Any dimensions are possible. Contact us with your requirements.

CS-ASA1

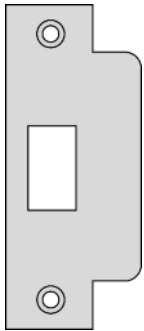

CS-ASA2

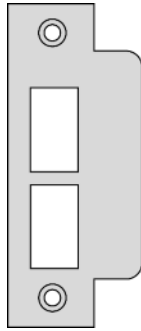

Material: .090" Brass, Bronze, Stainless Steel

Finishes: US3/605, US4/606, US10/612, US10B/613, US32D/630, US32/629

Fastener: **CS-ASA:** #12 WS or 12-24 MS;

CS-OM: #12 WS or 12-24 MS;

CS-T: #8 WS or 8-24 MS

CS-DA: #8 WS or 8-24 MS

Bolt Hole: Common sizes are: $\frac{11}{16}$ " x $1\frac{1}{4}$ " and $\frac{3}{4}$ " x $1\frac{1}{4}$ "; any size available.

Options:

- .050", .062", or .125" thickness

- TORX - security torx screws

- Finish on both sides

- Custom filler plates available

- Full lip

CS-OM

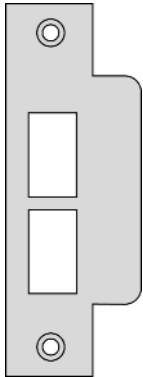

CS-T

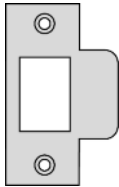

CS-DA

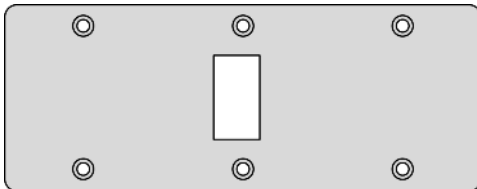

Fill out this form and email / fax form to info@rockwoodmfg.com / 800-922-9212.

Customer Information

Contact Name: _____ Date: _____
 Company Name: _____ Account #: _____
 Address: _____ Phone #/Fax #: _____
 City/State/Zip: _____ Email: _____

CS-ASA1 Lip to Centerline _____

Fill In All Dimensions

Select Bolt Hole Size
 1 1/16" x 1 1/4" 3/4" x 1 1/4"
 Other: W _____ x L _____

CS-ASA2 Lip to Centerline _____

Fill In All Dimensions

Select Bolt Hole Size
 1. 1 1/16" x 1 1/4" 3/4" x 1 1/4"
 Other: W _____ x L _____
 2. 1 1/16" x 1 1/4" 3/4" x 1 1/4"

CS-OM Lip to Centerline _____

Fill In All Dimensions

Select Bolt Hole Size
 1. 1 1/16" x 1 1/4" 3/4" x 1 1/4"
 Other: W _____ x L _____
 2. 1 1/16" x 1 1/4" 3/4" x 1 1/4"
 Other: W _____ x L _____

CS-T Lip to Centerline _____

Fill In All Dimensions

Select Bolt Hole Size
 1 1/16" x 1 1/4" 3/4" x 1 1/4" Other: W _____ x L _____

Order Form for CS-ASA1, CS-ASA2, CS-OM, CS-T

Quantity	Part #	Flat or Curved	LH	RH	MS or WS Fastener	Finish
Options						

CS-DA

Select Bolt Hole Size
 1 1/16" x 1 1/4" 3/4" x 1 1/4" Other: W _____ x L _____

Order Form for CS-DA

Is Door: Center Hung or Flush with Jam

Quantity	Part #	Jam Width	MS or WS Fastener	Finish
Options				

Corner Guards

No. 290, 291



- Material:** .050" Brass, Bronze, Stainless Steel
Finishes: Available in standard architectural finishes (see page 7).
Mounting: Self-adhesive mounting.
Ordering: Specify size.
Other: Other lengths available up to 96", leg widths up to 6".

No.	Standard Sizes	Top Corners	Weight
290	2" x 2" x 40"	square	2.4 lbs.
	2" x 2" x 48"		2.8 lbs.
	3" x 3" x 40"		3.5 lbs.
	3" x 3" x 48"		4.2 lbs.
291	2" x 2" x 40"	rounded	2.4 lbs.
	2" x 2" x 48"		2.8 lbs.
	3" x 3" x 40"		3.5 lbs.
	3" x 3" x 48"		4.2 lbs.

Corner Guards

No. 295, 296



- Material:** .050" Brass, Bronze, Stainless Steel
Finishes: Available in standard architectural finishes (see page 7).
Fastener: #6 x 5/8 OH SMS
Ordering: Specify size.
Other: Other lengths available up to 96", leg widths up to 6".

No.	Standard Sizes	Top Corners	Weight
295	2" x 2" x 40"	square	2.4 lbs.
	2" x 2" x 48"		2.8 lbs.
	3" x 3" x 40"		3.5 lbs.
	3" x 3" x 48"		4.2 lbs.
296	2" x 2" x 40"	rounded	2.4 lbs.
	2" x 2" x 48"		2.8 lbs.
	3" x 3" x 40"		3.5 lbs.
	3" x 3" x 48"		4.2 lbs.



**Latch Protector
No. 320**

- Material:** .105" Steel, Stainless Steel
- Finishes:** US2C (cadmium plated), US32D
- Fastener:** 5/16"-18 Carriage Bolts and Hex Drive Sex Nuts.
- Ordering:** Product number and finish.
- Features:** Jamb pin prevents prying of door. Non-handed.

No.	Material Size	Lock Type	Weight
320	3" x 11"	cylindrical or mortise	1.2 lbs.

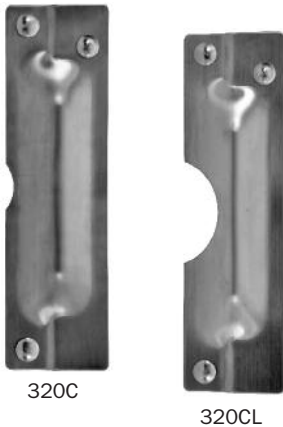

**Latch Protectors
No. 320C, 320CL**

- Material:** .105" Steel, Stainless Steel
- Finishes:** US2C (cadmium plated), US32D
- Fastener:** 5/16"-18 Carriage Bolts and Hex Drive Sex Nuts.
- Ordering:** Product number and finish.
- Features:** Jamb pin prevents prying of door. Non-handed.

No. 320C: Notched for 2 1/8" or less diameter rose on cylindrical lockset.

No. 320CL: Notched for 2 1/4" - 3 1/4" diameter rose on cylindrical lockset.

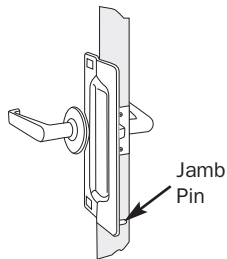

No.	Material Size	Lock Type	Weight
320C	3" x 11"	cylindrical	1.2 lbs.
320CL	3" x 11"	cylindrical	1.2 lbs.



**Latch Protector
No. 321**

- Material:** .105" Steel, Stainless Steel
- Finishes:** US2C (cadmium plated), US32D
- Fastener:** 5/16"-18 Carriage Bolts and Hex Drive Sex Nuts.
- Ordering:** Product number and finish.
- Features:** Fits rose or escutcheon 3 1/2" wide or less. Non-handed.

No.	Material Size	Lock Type	Weight
321	1 1/2" x 10"	mortise	0.7 lbs.

Latch Protectors & Lock Guard



**Latch Protector
 No. 322**

Material: .105" Steel, Stainless Steel
Finishes: US2C (cadmium plated), US32D
Fastener: ¼-20 Carriage Bolts and Hex Drive Sex Nuts.
Ordering: Product number and finish.
Features: Compact size. Non-handed.

No.	Material Size	Lock Type	Weight
322	1½" x 6"	cylindrical	1.1 lbs.



**Cast Latch Protector
 No. 325**

Material: .375" Solid Cast Brass
Finishes: US26D
Fastener: ¼-20 Thru Bolts & Finishing Washer.
Ordering: Product number and finish.
Features: Clean aesthetic design with no exposed fasteners.

No.	Material Size	Lock Type	Weight
325	1⅞" x 9½"	mortise or cylindrical	1.1 lbs.



**Anti-Vandal Latch Protector
 No. 330**

Material: .090" Stainless Steel
Finishes: US32D
Fastener: #8 x ¾ FH Stainless Steel Combo Screws.
Ordering: Product number and finish.
Features:

- Protects cylindrical locks from forced entry and vandalism.
- Fast and simple installation.
- Non-handed.
- Attractive appearance.

No.	Material Size	Lock Type	Weight
330	5⅝" x 6"	cylindrical	1.8 lbs.

ROCKWOOD

ASSA ABLOY

**D - Door Stops and Holders
from Rockwood**



DuraFlex[®] Bumpers

- *Non-yellowing*
- *Age-resistant*
- *Firm and Resilient*
- *Gray Pebble Finish*

Beautiful Finishes

ASSA ABLOY, the global leader
in door opening solutions



**Solid Cast Wall Stops
No. 400, 401, 402**

Material: Cast Brass with DuraFlex Bumper

Finishes: Available in standard architectural finishes (see page 7).

Features: Concealed mounting, convex bumper. Back plate prevents damage to wall.

No.	Bumper	Fastener	Size	Weight	ANSI A156.16
400	Convex	#6 x 1½ FH SMS, plastic toggle	2 ⁷ / ₁₆ " dia., 1" projection	3.3 lbs./10	L02101
401	Convex	#8 x 1 RH WS, plastic anchor	2 ⁷ / ₁₆ " dia., 1" projection	3.3 lbs./10	L02101
402	Convex	8-32 x 1 TH MS, lead anchor	2 ⁷ / ₁₆ " dia., 1" projection	3.3 lbs./10	L02101



**Solid Cast Wall Stops
No. 403, 404, 405**

Material: Cast Brass with DuraFlex Bumper

Finishes: Available in standard architectural finishes (see page 7).

Features: Concealed mounting, concave bumper. Back plate prevents damage to wall.

No.	Bumper	Fastener	Size	Weight	ANSI A156.16
403	Concave	#6 x 1½ FH SMS, plastic toggle	2 ⁷ / ₁₆ " dia., 1" projection	3.3 lbs./10	L02251
404	Concave	#8 x 1 RH WS, plastic anchor	2 ⁷ / ₁₆ " dia., 1" projection	3.3 lbs./10	L02251
405	Concave	8-32 x 1 TH MS, lead anchor	2 ⁷ / ₁₆ " dia., 1" projection	3.3 lbs./10	L02251



**Solid Cast Wall Stop
No. 412**

Material: Cast Brass with DuraFlex Bumper

Finishes: Available in standard architectural finishes (see page 7).

Features: For where concealed mounting is not desired. School version.

Options: Tamperproof Torx screws

No.	Bumper	Fastener	Size	Weight	ANSI A156.16
412	Convex	WS and plastic anchor	2 ⁷ / ₁₆ " dia., 1" projection	3.5 lbs./10	L12111



**Solid Cast Wall Stop
No. 415**

Material: Cast Brass with DuraFlex Bumper

Finishes: Available in standard architectural finishes (see page 7).

Features: Large size with flush back plate spreads impact of heavy or uncontrolled door contact—avoiding damage to wall. Universal screw pack is included for all wall conditions.

No.	Bumper	Fastener	Size	Weight	ANSI A156.16
415	Convex	1 - 8-32 x 2 RH MS and toggle bolt	4" dia., ¾" projection	1.7 lbs. each	L02111
		1 - 12-24 x 1¼ RH MS and lead anchor			
		3 - #8 x 1¼ FH SMS and plastic anchors			
		3 - 8-32 x ¼ FH MS			



**Solid Cast Wall Stop
 No. 416**

Material: Cast Brass with DuraFlex Bumper
Finishes: Available in standard architectural finishes (see page 7).
Features: For use where concealed mounting is not desired. School version.
Options: Tamperproof Torx screws

No.	Bumper	Fastener	Size	Weight	ANSI A156.16
416	Concave	WS and plastic anchor	2 ⁷ / ₁₆ " dia., 1" projection	3.5 lbs./10	L12261



**Wrought Wall Stops
 No. 406, 407, 408**

Material: Wrought Brass, Bronze, and Stainless Steel with DuraFlex Bumper
Finishes: Available in standard architectural finishes (see page 7).
Features: Concealed mounting, convex bumper. Back plate prevents damage to wall.

No.	Bumper	Fastener	Size	Weight	ANSI A156.16
406	Convex	#8 x 1 ¹ / ₄ TH SMS, plastic toggle	2 ¹ / ₂ " dia., ³ / ₄ " projection	1.8 lbs./10	L02101
407	Convex	#8 x 1 RH WS, plastic anchor	2 ¹ / ₂ " dia., ³ / ₄ " projection	1.8 lbs./10	L02101
408	Convex	8-32 x 1 TH MS, lead anchor	2 ¹ / ₂ " dia., ³ / ₄ " projection	1.8 lbs./10	L02101



**Wrought Wall Stops
 No. 409, 410, 411**

Material: Wrought Brass, Bronze, and Stainless Steel with DuraFlex Bumper
Finishes: Available in standard architectural finishes (see page 7).
Features: Concealed mounting, concave bumper. Back plate prevents damage to wall.
Options: DuraFlex Bumper available in standard grey or optional black.

No.	Bumper	Fastener	Size	Weight	ANSI A156.16
409	Concave	#8 x 1 ¹ / ₄ TH SMS, plastic toggle	2 ¹ / ₂ " dia., ³ / ₄ " projection	1.8 lbs./10	L02251
410	Concave	#8 x 1 RH WS, plastic anchor	2 ¹ / ₂ " dia., ³ / ₄ " projection	1.8 lbs./10	L02251
411	Concave	8-32 x 1 TH MS, lead anchor	2 ¹ / ₂ " dia., ³ / ₄ " projection	1.8 lbs./10	L02251



**Wrought Wall Stop
No. 426**

Material: Wrought Brass and Stainless Steel with DuraFlex Bumper

Finishes: US3, US32D

Other: Concealed mounting.

No.	Bumper	Fastener	Size	Weight	ANSI A156.16
426	Concave	#8 x 1¼ TH SMS, plastic toggle and plastic anchor	1⅞" dia., 1" projection	2.3 lbs./10	L02251



**Solid Cast Wall Stop
No. 430**

Material: Solid Brass with DuraFlex Bumper

Finishes: Available in standard architectural finishes (see page 7).

Features:

- Compact design for use on hotel bathroom doors swinging into the tub area, or where an inconspicuous bumper is desired.
- Concealed mounting.

No.	Bumper	Fastener	Size	Weight	ANSI A156.16
430	Convex	#6 x ¾ OH SMS, plastic anchor	1" dia., ⅞" projection	1.0 lbs./10	L02101



**Wall Stop
No. 431**

Material: Gray DuraFlex Bumper

Finishes: Gray

Features: Economical bumper for applications where a completely concealed mounting is not required.

No.	Bumper	Fastener	Size	Weight	ANSI
431	Concave	#8 x 1¼ TR SMS, #8 flat washer, plastic toggle	1⅞" dia., 1⅝" projection	1.0 lbs./10	—



**Wall Stop
No. 432W**

Material: White DuraFlex Bumper

Finishes: White

Features:

- Economical.
- Self-adhesive mounting.

No.	Bumper	Fastener	Size	Weight	ANSI
432W	Concave	self-adhesive tape	1⅞" dia., ⅞" projection	1.0 lbs./10	—

**Low Dome Stops
No. 440, 441**



- Material:** Solid Cast Brass with DuraFlex Bumper
- Finishes:** Available in standard architectural finishes (see page 7).
- Other:** No. 441 is packed with both WS and MS fasteners.
- Features:** For doors without thresholds (not undercut).
- Options:** Exterior Pack screw packs; stainless steel plated to match — use EXP suffix (440 x EXP) when ordering.

No.	Fastener	Base	Height	Weight	ANSI A156.16
440	#12 x 1¼ FH WS, plastic anchor	¼" h x 1⅞" dia.	1⅞"	2.1 lbs./10	L02141
441	#12 x 1½ FH WS, plastic anchor; 12-24 x 1 FH MS, lead anchor	¼" h x 1⅞" dia.	1⅞"	2.5 lbs./10	L02141

**Dome Stop Combination Unit
No. 441CU**



- Material:** Solid Cast Brass with DuraFlex Bumper
- Finishes:** Available in standard architectural finishes (see page 7).
- Other:** Set consists of 1 each No. 441 and 1 each No. 444. For use at doors with or without a threshold.
- Features:** Convertible for undercut or not undercut doors.
- Options:** Exterior Pack screw packs; stainless steel plated to match — use EXP suffix (441CU x EXP) when ordering.

No.	Fastener	Base	Height	Weight	ANSI A156.16
441CU	#12 x 1½ FH WS, plastic anchor; 12-24 x 1½ FH MS, lead anchor	dome stop: ¼" h x 1⅞" dia. riser: ⅜" h x 1⅞" dia.	1⅞" or 1½"	3 lbs./10	L02141/ L02161
444	Cast Riser Only	⅜" h x 1⅞" dia.	⅜"	10 ozs./10	

**Cast Universal Dome Stop
No. 441H**



- Material:** Solid Cast Brass with DuraFlex Bumper
- Finishes:** Available in standard architectural finishes (see page 7).
- Features:** Low lip dome stop with height of high dome stop, eliminates the need to determine requirement for traditional low or high dome stop – one stop for all applications. Integral cast pin for added strength. Universal screw pack included for all floor conditions.
- Options:** Exterior Pack screw packs; stainless steel plated to match — use EXP suffix (441H x EXP) when ordering.

No.	Fastener	Base	Height	Weight	ANSI A156.16
441H	#12 x 1¼ FH WS, plastic anchor 12-24 x 1 FH MS, lead anchor	⅞" h x 1⅞" dia.	1⅞"	3.2 lbs./10	L02141/ L02161

Dome Stops, Door Stops & Risers



**High Dome Stops
No. 442, 443**

Material: Solid Cast Brass with DuraFlex Bumper
Finishes: Available in standard architectural finishes (see page 7).
Other: No. 443 is packed with both WS and MS fasteners.
Features: For doors with thresholds or undercut doors.
Options: Exterior Pack screw packs; stainless steel plated to match — use EXP suffix (442 x EXP) when ordering.

No.	Fastener	Base	Height	Weight	ANSI A156.16
442	#12 x 1½ FH WS, plastic anchor	½" h x 1⅞" dia.	1½"	2.8 lbs./10	L02161
443	#12 x 1½ FH WS, plastic anchor; 12-24 x 1 FH MS, lead anchor	½" h x 1⅞" dia.	1½"	3.2 lbs./10	L02161



**Door Stop Riser
No. 449**

Material: Aluminum
Finishes: Mill Aluminum or Painted to Match
Ordering: Specify finish and thickness; ¼", ⅜", ½", ⅝", ¾", 1"
Other: Full size carpet riser provides sturdy base for mounting the No. 440 or No. 442 dome stop.

No.	Fastener	Base	Height	Weight
449	#12 WS, plastic anchor	1⅞" dia.	As specified	1.6 lbs./10



**Heavy Duty Door Stop
No. 445**

Material: Solid Cast Brass with DuraFlex Bumper
Finishes: Available in standard architectural finishes (see page 7).
Features: Extra heavy duty dome type stop for heavy and high frequency doors.
Options: Exterior Pack screw packs; stainless steel plated to match — use EXP suffix (445 x EXP) when ordering.

No.	Fastener	Base	Height	Weight
445	2 ea. #12 x 1½ FH SMS, plastic anchor; 12-24 x 1 FH MS, lead anchor	2" x 4"	1⅞"	5.5 lbs./10



**Door Stop
No. 446**

Material: Brass with DuraFlex Bumper
Finishes: Available in standard architectural finishes (see page 7).
Features: Modern style universal stop.
Options: DuraFlex Bumper available in standard grey or optional black.

No.	Fastener	Base	Height	Weight
446	#12 x 1½ WS, plastic anchor; 12-24 x 1 FH MS, lead anchor	1¼"	1½"	0.5 lbs.

**Curved Roller Stop
 No. 455**

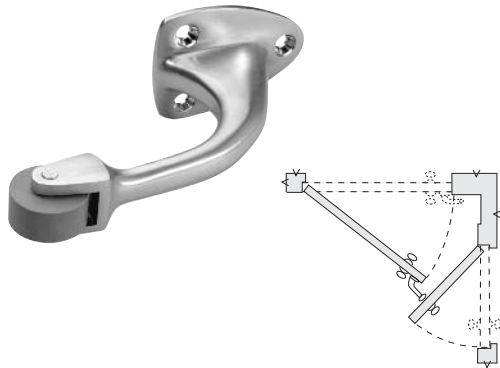

Material: Solid Cast Brass with DuraFlex Bumper

Finishes: Available in standard architectural finishes (see page 7).

Features: For use where doors swing into each other at odd angles.

No.	Fastener	Base	Projection	Weight	ANSI A156.16
455	3 ea. #8 x 3/4 OH SMS	1 5/8" x 2 1/4"	3"	5.6 lbs./10	L02211

**Straight Roller Stop
 No. 456**

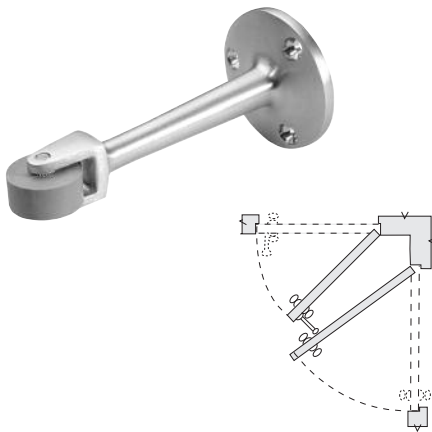

Material: Solid Cast Brass with DuraFlex Bumper

Finishes: Available in standard architectural finishes (see page 7).

Features: For use where doors swing into each other at right angles.

No.	Fastener	Base	Projection	Weight	ANSI A156.16
456	3 ea. #8 x 3/4 OH SMS	2" dia.	4 9/16"	5.3 lbs./10	L02191

**Straight Roller Stop
 No. 456L**



Material: Solid Cast Brass with DuraFlex Bumper

Finishes: Available in standard architectural finishes (see page 7).

Features: For use where doors swing into each other at right angles.

No.	Fastener	Base	Projection	Weight	ANSI A156.16
456L	3 ea. #8 x 3/4 OH SMS	2" dia.	6 1/4"	5.3 lbs./10	L02191



**Kick Down Door Stop
No. 458**

Material: Cast Zinc with DuraFlex Bumper

Finishes: Available in Bright Brass (BRS), Dull Bronze (BRZ), and Bright Chrome Plate (CRM).

Features:

- Uses replacement bumper 461B.
- DuraFlex bumper provides reliable grip on floor.

No.	Fastener	Base	Projection	Weight	ANSI A156.16
458	3 ea. #8 x 1 OH SMS	1 ⁵ / ₈ " x 1 ⁷ / ₈ "	4"	3.3 lbs./10	L01382



**Spring Loaded Plunger Stop
No. 459**

Material: Solid Cast Brass with DuraFlex Bumper

Finishes: Available in standard architectural finishes (see page 7).

Features:

- Uses replacement bumper 461B.
- Foot operated, spring loaded.

No.	Fastener	Base	Projection	Weight	ANSI A156.16
459	3 ea. #8 x 3/4 OH SMS	1 ³ / ₈ " x 5 ³ / ₈ "	1 ⁷ / ₈ "	13.3 lbs./10	L01411



**Kick Down Door Stop
No. 460**

Material: Solid Cast Aluminum with DuraFlex Bumper

Finishes: Spray painted Silver (ALM), Brass (BRS), Bronze (BRZ) or Brown to match US10B (ORB).

Features:

- Uses replacement bumper 461B.
- DuraFlex bumper provides reliable grip on floor.

No.	Fastener	Base	Projection	Weight	ANSI A156.16
460	4 ea. #8 x 1 FH SMS	2 ¹ / ₁₆ " x 1 ³ / ₈ "	4"	2.7 lbs./10	L01382

**Kick Down Door Stop
 No. 461**



Material: Solid Cast Brass with DuraFlex Bumper

Finishes: Available in standard architectural finishes (see page 7).
 DuraFlex Bumper available in grey or black.

- Features:**
- Uses replacement bumper 461B.
 - DuraFlex bumper provides reliable grip on floor.
 - A unique assembly design that conceals the axle in the base.

No.	Fastener	Base	Projection	Weight	ANSI A156.16
461	4 ea. #8 x 3/4 OH SMS	2 1/4" x 1 1/4"	3 5/8"	6.1 lbs./10	L01382

**Kick Down Door Stop
 No. 461L**



Material: Solid Cast Brass with DuraFlex Bumper

Finishes: Available in standard architectural finishes (see page 7).
 DuraFlex Bumper available in grey or black.

- Features:**
- Uses replacement bumper 461B.
 - DuraFlex bumper provides reliable grip on floor.
 - A unique assembly design that conceals the axle in the base.
 - For use with doors up to 3" door-to-floor clearance.

No.	Fastener	Base	Projection	Weight	ANSI A156.16
461L	4 ea. #8 x 3/4 OH SMS	2 1/4" x 1 1/4"	4 5/8"	7.1 lbs./10	L01382

Heavy Duty Door Stops



**Heavy Duty Door Stop
No. 462**

Material: Flame Resistant High Impact Bumper

Finishes: US2C

Mounting: Drill 1" diameter x 2½" deep hole, fill with anchoring grout.

No.	Size	Mounting Bolt	Weight
462	2"d x 1½"h	⅝" x 2½"	0.6 lbs.



**Heavy Duty Door Stop
No. 463**

Material: Flame Resistant High Impact Bumper

Finishes: US4, US26D, US32D

Mounting: Drill 1" diameter x 2½" deep hole, fill with anchoring grout.

Other: Replaceable bumper retained by security torx MS.

No.	Size	Mounting Bolt	Weight
463	2"d x 1¾"h	½" x 2½"	0.5 lbs.



**Heavy Duty Door Stop with Holder
No. 464**

Material: Cast Brass and Black Rubber Bumper.

Finishes: US26D

Mounting: Body: 1 ea. ½ x 4½ Lag Bolt; 1 ea. Lead Shield;
2 ea. #8 x 1¼ FH SMS

Cap: 1 ea. 8-32 x ⅜ RH MS

Features: Offers maximum protection needed for heavily used doors. Supplied with holder and catch.

No.	Size	Weight
464	3"d x 3"h	1.8 lbs.



**Heavy Duty Door Stop
No. 465**

Material: Wrought Brass and Black Rubber Bumper

Finishes: US26D

Mounting: Body: 1 ea. ½ x 4½ Lag Bolt
1 ea. Lead Shield

Cap: 1 ea. 8-32 x ⅜ RH MS

Features: Offers maximum protection needed for heavily used doors.

No.	Size	Weight
465	3⅜"d x 2"h	1.3 lbs.



**Heavy Duty Door Stop
 No. 466**

Material: Flame Resistant Molded Rubber Bumper

Finishes: Black

Mounting: Drill 1" diameter x 2½" deep hole, fill with anchoring grout.

Features: • Ideal for use in high vandalism or security areas.
 • No exposed fasteners.

No.	Size	Mounting Bolt	Weight
466	2"d x 1½"h	5/8" x 2½"	0.6 lbs.



**Heavy Duty Door Stop
 No. 467**

Material: Flame Resistant Molded Rubber Bumper

Finishes: Black

Mounting: Drill 1" diameter x 2½" deep hole, fill with anchoring grout.

Features: • Suitable for concrete floor or wall mounting.
 • Ideal for use in high vandalism or security areas.
 • No exposed fasteners.

No.	Size	Mounting Bolt	Weight
467	2"d x 3½"h	5/8" x 2½"	0.9 lbs.



**Heavy Duty Door Stop
 No. 468**

Material: Wrought Stainless Steel and Black Rubber Bumper

Finishes: US32D

Mounting: Drill 1½" diameter x 7" deep hole, fill with anchoring grout.

Features: • Ideal for use in high vandalism or security area.
 • No exposed fasteners.

No.	Size	Mounting Bolt	Weight
468	2"d x 3"h	1" x 7"	2.6 lbs.

**Door Stops
 No. 470, 471**



No. 471

Material: Cast Brass with DuraFlex Bumper

Finishes: Available in standard architectural finishes (see page 7).

Options: Exterior Pack screw packs; stainless steel plated to match — use EXP suffix (470 x EXP) when ordering.

No.	Fastener	Base	Height	Weight	ANSI A156.16
470	3 ea. #12 x 1¼ FH WS; 3 ea. plastic anchors	2½" dia.	3"	0.7 lbs.	L02121
471	1 ea. 5/16 - 18 x 1¾ stud, lead anchor; #8 x ¾ OH SMS, plastic anchor	2½" dia.	3"	0.7 lbs.	L02131

**Door Stops with Keepers
 No. 472, 473**



No. 473

Material: Cast Brass with DuraFlex Bumper

Finishes: Available in standard architectural finishes (see page 7).

Other: Keeper size 1"w x 1¾"h.

Options: Exterior Pack screw packs; stainless steel plated to match — use EXP suffix (472 x EXP) when ordering.

No.	Fastener	Base	Height	Weight	ANSI A156.16
472	3 ea. #12 x 1¼ FH WS; 3 ea. plastic anchors Keeper: 2 ea. #12 x 1¼ FH WS; 2 ea. plastic anchors	2½" dia.	3¾"	0.9 lbs.	L01361
473	5/16 - 18 x 1¾ stud, lead anchor; #8 x ¾ OH SMS, plastic anchor Keeper: 2 ea. #12 x 1¼ FH WS; 2 ea. plastic anchors	2½" dia.	3¾"	0.9 lbs.	L01371

**Door Stops
 No. 474, 475**

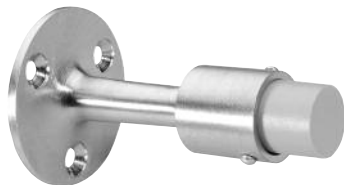

No. 474

Material: Cast Brass with DuraFlex Bumper.

Finishes: Available in standard architectural finishes (see page 7).

No.	Fastener	Base	Projection	Weight	ANSI A156.16
474	3 ea. #12 x 1¼ FH WS, 3 ea. plastic anchors	2¼" dia.	3¾"	0.6 lbs.	L02011
475	1 ea. ⅝ - 18 x 1¾ stud, lead anchor; #8 x ¾ OH SMS, plastic anchor	2¼" dia.	3¾"	0.6 lbs.	L02021

**Door Stops with Keepers
 No. 476, 477**

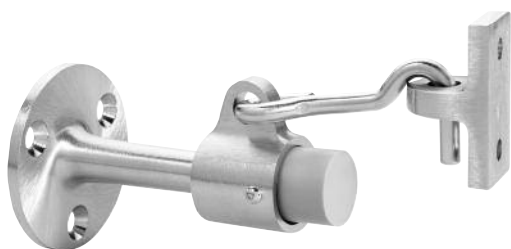

No. 476

Material: Solid Cast Brass with DuraFlex Bumper

Finishes: Available in standard architectural finishes (see page 7).

Other: Keeper size 1"w x 1¾"h.

No.	Fastener	Base	Projection	Weight	ANSI A156.16
476	3 ea. #12 x 1¼ FH WS, 3 ea. plastic anchors Keeper: 2 ea. #12 x 1¼ FH WS; 2 ea. plastic anchors	2¼" dia.	3¾"	0.8 lbs.	L01341
477	⅝ - 18 x 1¾ stud, lead anchor; #8 x ¾ OH SMS, plastic anchor Keeper: 2 ea. #12 x 1¼ FH WS; 2 ea. plastic anchors	2¼" dia.	3¾"	0.8 lbs.	L01351

**Door Stops
No. 480, 481**



- Material:** Solid Cast Brass with DuraFlex Bumper
- Finishes:** Available in standard architectural finishes (see page 7).
- Features:**
- Uses replacement bumper 461B.
 - Heavy duty and ideal for use on heavy doors or in high traffic areas.
- Options:**
- DuraFlex Bumper available in standard grey or optional black.
 - Exterior Pack screw packs; stainless steel plated to match — use EXP suffix (480 x EXP) when ordering.

No.	Fastener	Base	Height	Weight
480	3 ea. #12 x 1¼ FH WS, 3 ea. plastic anchors	2½" x 1¾"	1⅝"	5.8 lbs./10
481	3 ea. 12-24 x 1 FH MS, 3 ea. lead anchors	2½" x 1¾"	1⅝"	5.8 lbs./10

**Door Stops
No. 480H, 481H**



- Material:** Solid Cast Brass with DuraFlex Bumper
- Finishes:** Available in standard architectural finishes (see page 7).
- Features:**
- Uses replacement bumper 461B.
 - Heavy duty and ideal for use on heavy doors or in high traffic areas.
- Options:**
- DuraFlex Bumper available in standard grey or optional black.
 - Exterior Pack screw packs; stainless steel plated to match — use EXP suffix (480H x EXP) when ordering.

No.	Fastener	Base	Height	Weight
480H	3 ea. #12 x 1¼ FH WS, 3 ea. plastic anchors	2½" x 1¾"	2¼"	6.2 lbs./10
481H	3 ea. 12-24 x 1 FH MS, 3 ea. lead anchors	2½" x 1¾"	2¼"	6.2 lbs./10

**Heavy Duty Mounting Plate
No. 481MP**



- Material:** Aluminum and Steel
- Finishes:** Powder coat to match stop finish.
- Features:** ⅜" aluminum base plate for securely anchoring 481 or 481H door stops in heavy use areas.
- Installation:** Requires 3½" diameter hole 3½" deep. Fill with quick drying cement and set anchor plate flush to finished floor with hole pattern at appropriate location for door stop to interface with door surface.

No.	Fastener	Base	Height	Weight
481MP	None	3" dia	Flush to floor	4.5 lbs./10



**Door Stop
No. 482**

- Material:** Solid Cast Brass with DuraFlex Bumper
- Finishes:** Available in standard architectural finishes (see page 7).
- Features:**
- Uses replacement bumper 461B.
 - Heavy duty and ideal for use on heavy doors or in high traffic areas.
- Options:**
- DuraFlex Bumper available in standard grey or optional black.
 - Exterior Pack screw packs; stainless steel plated to match — use EXP suffix (482 x EXP) when ordering.

No.	Fastener	Base	Height	Weight	ANSI A156.16
482	5/16-18 x 1 3/4 stud, lead anchor; #12 x 1 1/4 FH WS, plastic anchor	1 1/2" x 2 1/2"	2 5/8"	6.5 lbs./10	L02131



**Door Stop
No. 483**

- Material:** Solid Cast Brass with DuraFlex Bumper
- Finishes:** Available in standard architectural finishes (see page 7).
- Features:**
- Uses replacement bumper 461B.
 - Heavy duty and ideal for use on heavy doors or in high traffic areas.
- Options:**
- DuraFlex Bumper available in standard grey or optional black.
 - Exterior Pack screw packs; stainless steel plated to match — use EXP suffix (483 x EXP) when ordering.

No.	Fastener	Base	Height	Weight	ANSI A156.16
483	5/16-18 x 1 3/4 stud, lead anchor; #12 x 1 1/4 FH WS, plastic anchor	1 5/8" x 2 5/8"	2 3/4"	6.7 lbs./10	L02131



**Door Stop with Keeper
No. 485**

- Material:** Solid Cast Brass with DuraFlex Bumper
- Finishes:** Available in standard architectural finishes (see page 7).
- Features:**
- Uses replacement bumper 461B.
 - Heavy duty and ideal for use on heavy doors or in high traffic areas.
- Options:**
- DuraFlex Bumper available in standard grey or optional black.
 - Exterior Pack screw packs; stainless steel plated to match — use EXP suffix (485 x EXP) when ordering.

No.	Fastener	Base	Height	Weight	ANSI A156.16
485	5/16-18 x 1 3/4 stud, lead anchor; #12 x 1 1/4 FH WS, plastic anchor	1 5/8" x 2 5/8"	3"	7.8 lbs./10	L01371
Keeper	2 ea. #10 x 1 FH SMS	1" x 2"			



**Angle Door Stop
No. 486**

Material: Steel with DuraFlex Bumper

Finishes: US2C

Features: For undercut doors up to 1½".

No.	Fastener	Base	Height	Weight
486	2 ea. #12 x 1½ FH SMS, 2 ea. plastic anchors	1" x 2½"	2⅝"	4 lbs./10



**Heavy Duty Wall Stop
No. 487**

Material: Solid Cast Brass with DuraFlex Bumper

Finishes: US26D

Options: MS and anchors.

Features: Sloping design resists vandalism.

No.	Fastener	Base	Projection	Weight
487	3 ea. #10 x 1 FH SMS, 3 ea. plastic anchors	2⅛" x 2⅞"	3½"	0.8 lbs.



**Door Stop
No. 488**

Material: Solid Brass

Finishes: Available in standard architectural finishes (see page 7).

Features: For single doors.

No.	Fastener	Base	Height	Weight
488	2 ea. #12 x 1½ FH WS, 2 ea. plastic anchors; 2 ea. 12-24 x 1 FH MS	1½" x 2"	1"	2.2 lbs./10



**Door Stop
No. 489**

Material: Solid Brass

Finishes: Available in standard architectural finishes (see page 7).

Features: For single or pair of doors.

No.	Fastener	Base	Height	Weight
489	4 ea. #12 x 1½ FH WS, 2 ea. plastic anchors; 4 ea. 12-24 x 1 FH MS	3" x 2"	1"	4.1 lbs./10

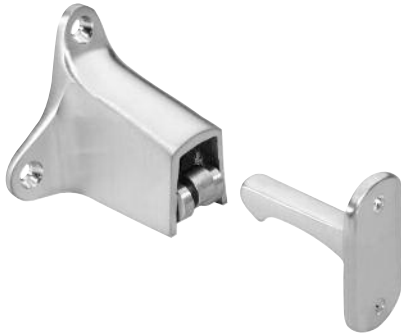

**Door Holder & Stop
No. 490**

Material: Cast Brass
Finishes: US26D
Other: Holder base: 2³/₄"w x 2¹/₂"h
 Holder projection: 2¹/₈"
 Strike base: 1"w x 2"h
 Strike projection: 2"

No.	Fastener	Weight	ANSI A156.16
490	5 ea. #8 x 1 OH SMS, 3 ea. plastic anchors; 3 ea. 8-32 x 1 ¹ / ₄ FH MS	0.8 lbs.	L01291



**Automatic Door Holder & Stop
No. 491, 491R, 491S**

Material: Cast Brass
Finishes: Available in standard architectural finishes (see page 7).
Other: Holder base: 2³/₄"w x 2¹/₂"h
 Holder projection: 2¹/₈"
 Strike base: 4"w x 2"h
 Strike projection: 1¹/₄"

Options: Strike risers available for larger clearances.
Features:

- For applications requiring door hold-open on a frequent basis.
- Screw hole design allows for precise alignment and then permanent attachment.

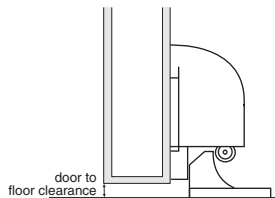

No.	Fastener	Strike	Clearance	Weight	ANSI A156.16
491	Strike: 3 ea. #12 x 1 ¹ / ₄ FH WS, 3 ea. plastic anchors Body: 4 ea. #10 x 1 ¹ / ₄ FH WS	floor	½" or less door to floor	1.5 lbs.	L01301
491R	Strike: 3 ea. 12-24 x 1 FH MS, 3 ea. lead anchors Body: 4 ea. #10 x 1 ¹ / ₄ FH WS	floor	½" or less door to floor	1.5 lbs.	L01301
491S	Strike: 3 ea. 12-24 x 1 FH MS, 3 lead anchors Body: 4 ea. 10-24 x 1 FH MS; 4 ea. 10-24 x 1 ³ / ₈ sex bolt	floor	½" or less door to floor	1.5 lbs.	L01301

**Automatic Door Holder & Stop
No. 494, 494R, 494S**



Material: Cast Brass

Finishes: Available in standard architectural finishes (see page 7).

Other: Holder base: 2³/₄"w x 2¹/₂"h
Holder projection: 2¹/₈"
Strike base: 2"w x 3"h
Strike projection: 3¹/₄"

- Features:**
- For applications requiring door-hold-open on a frequent basis.
 - Screw hole design allows for precise alignment and then permanent attachment.

No.	Fastener	Strike	Clearance	Weight	ANSI A156.16
494	Strike: 3 ea. #12 x 1 ¹ / ₄ FH WS, 3 ea. plastic anchors Body: 4 ea. # 10 x 1 ¹ / ₄ FH WS	wall	3 ³ / ₄ " wall to door	1.7 lbs.	L01291
494R	Strike: 3 ea. 12-24 x 1 FH MS, 3 ea. lead anchors Body: 4 ea. #10 x 1 ¹ / ₄ FH WS	wall	3 ³ / ₄ " wall to door	1.7 lbs.	L01291
494S	Strike: 3 ea. 12-24 x 1 FH MS, 3 ea. lead anchors Body: 4 ea. 10-24 x 1 FH MS; 4 ea. 10-24 x 1 ³ / ₈ sex bolt	wall	3 ³ / ₄ " wall to door	1.7 lbs.	L01291

Door Stops

Door Stops No. 505, 508



Material: Cast Brass with DuraFlex Bumper

Finishes: Available in standard architectural finishes (see page 7).

Options: DuraFlex Bumper available in standard white or optional grey and black.

No.	Fastener	Base	Projection	Weight	ANSI A156.16
505	10-24 x 1¼ hanger bolt	1" dia.	3"	1.6 lbs./10	L02031
508	10-24 x 1¼ hanger bolt	1" dia.	4"	2.2 lbs./10	L02031

Aluminum Door Stop No. 517



Material: Cast Aluminum with DuraFlex Bumper

Finishes: Bright Brass (BRS) and Burnished Aluminum (ALM)

No.	Fastener	Base	Projection	Weight	ANSI
517	2 ea. #8 x ¾ OH SMS	1½" dia.	3¾"	1.1 lbs./10	—

Door Stop No. 518



Material: Cast Brass with DuraFlex Bumper

Finishes: Available in standard architectural finishes (see page 7).

Options: DuraFlex Bumper available in standard white or optional grey and black.

No.	Fastener	Base	Projection	Weight	ANSI
518	2 ea. #8 x ¾ OH SMS	1½" dia.	3¾"	2.7 lbs./10	—

Door Stop No. 519



Material: Cast Brass with DuraFlex Bumper

Finishes: Available in standard architectural finishes (see page 7).

Options: DuraFlex Bumper available in standard white or optional grey and black.

No.	Fastener	Base	Projection	Weight	ANSI A156.16
519	10-24 x 1¼ hanger bolt	1¼" dia.	3¼"	2.5 lbs./10	L02031

Replacement Bumper No. 520



Material: DuraFlex Bumper

Options: Available in standard white or optional grey and black.

Weight: 0.7 lbs./10

Other: Bumper replacement for No. 505, 508, 517, 518, 519.

**Spring Base Door Stop
No. 525**



Material: Spring Steel
Finishes: Antique Brass (ANT), Bright Brass (BRS), Bright Nickel (NP)
Features: Heavy spring construction for durable wear.

No.	Fastener	Base	Projection	Weight	ANSI A156.16
525	6 x 3/4 SMS	1" dia.	3"	0.7 lbs./10	L02051

**Spring Base Door Stop
No. 526**

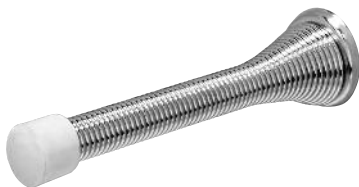

Material: Spring Steel
Finishes: Antique Brass (ANT), Bright Brass (BRS), Bright Nickel (NP)
Features: Heavy spring construction for durable wear.

No.	Fastener	Base	Projection	Weight	ANSI A156.16
526	6 x 3/4 SMS	1" dia.	4"	0.8 lbs./10	L02061

**Heavy Duty Hinge Pin Stop
No. 528**



Material: Wrought Steel with Rubber Bumpers
Finishes: Antique Brass (ANT), Bright Brass (BRS), Bright Nickel (NP)
Features:

- Positive slip proof adjustment.
- Heavy wrought steel construction works with both 1/4" and 5/16" hinge pins.

No.	Door Opening Adjustment	Weight	ANSI A156.16
528	70° to 100°	1.3 lbs./10	L02223



**Heavy Duty Concealed
 11000 Series**

Material: Stainless Steel

Finishes: US32D (other BHMA finishes are available upon request)

Fastener: Wood Door Jamb: 4 ea. #14 x 1½ FH WS
 Wood Door: 2 ea. #18 x 2½ FH WS

Metal Door Jamb: 4 ea. ¼-20 x ¾ FH MS
 Metal Door: 2 ea. ⅝-18 x 1½ FH MS

Ordering:

- Indicate model number, finish, conflicting hardware, mounting means of the door, door opening, and thickness.
- **All stainless steel components add Prefix N.**

Other:

- For exterior, vestibule or interior single or double acting doors.
- Maximum opening 110°, minimum door thickness 1¾".

Features: Hold-open knob can be disengaged to act as a stop only (applies to hold-open function only).

Door Opening

No.	Function	Butts/Offset Pivots	Center Hung	Weight	ANSI A156.8
11011	hold open	27" - 29 ¹⁵ / ₁₆ "	30" - 32 ¹⁵ / ₁₆ "	5.5 lbs.	C01511
11012	hold open	30" - 35 ⁵ / ₁₆ "	33" - 38 ¹⁵ / ₁₆ "	5.7 lbs.	C01511
11013	hold open	36" - 39 ¹⁵ / ₁₆ "	39" - 42 ¹⁵ / ₁₆ "	5.8 lbs.	C01511
11014	hold open	40" - 43 ¹⁵ / ₁₆ "	43" - 46 ¹⁵ / ₁₆ "	6.0 lbs.	C01511
11015	hold open	44" + Greater	47" + Greater	6.0 lbs.	C01511
11021	stop only	27" - 29 ¹⁵ / ₁₆ "	30" - 32 ¹⁵ / ₁₆ "	5.5 lbs.	C01541
11022	stop only	30" - 35 ⁵ / ₁₆ "	33" - 38 ¹⁵ / ₁₆ "	5.7 lbs.	C01541
11023	stop only	36" - 39 ¹⁵ / ₁₆ "	39" - 42 ¹⁵ / ₁₆ "	5.8 lbs.	C01541
11024	stop only	40" - 43 ¹⁵ / ₁₆ "	43" - 46 ¹⁵ / ₁₆ "	6.0 lbs.	C01541
11025	stop only	44" + Greater	47" + Greater	6.0 lbs.	C01541
11031	friction	27" - 29 ¹⁵ / ₁₆ "	30" - 32 ¹⁵ / ₁₆ "	5.5 lbs.	C01531
11032	friction	30" - 35 ⁵ / ₁₆ "	33" - 38 ¹⁵ / ₁₆ "	5.7 lbs.	C01531
11033	friction	36" - 39 ¹⁵ / ₁₆ "	39" - 42 ¹⁵ / ₁₆ "	5.8 lbs.	C01531
11034	friction	40" - 43 ¹⁵ / ₁₆ "	43" - 46 ¹⁵ / ₁₆ "	6.0 lbs.	C01531
11035	friction	44" + Greater	47" + Greater	6.0 lbs.	C01531



**Medium Duty Concealed
14000 Series**

Material: Stainless Steel

Finishes: US32D (other BHMA finishes are available upon request)

Fastener: Wood Door Jamb: 4 ea. #10 x 1½ FH WS
 Wood Door: 2 ea. #10 x 1½ RH WS
 Metal Door Jamb: 4 ea. 10-32 x ½ FH MS
 Metal Door: 2 ea. 10-32 x 1¼ RH MS

Ordering:

- Indicate model number, finish, conflicting hardware, mounting means of the door, door opening, and thickness.
- **All stainless steel components add Prefix N.**

Other:

- For interior single or double acting doors.
- Maximum opening 110°, minimum door thickness 1⅜".

No.	Function	Door Opening		Weight	ANSI A156.8
		Butts/Offset Pivots	Center Hung		
14011	hold open	18" - 23 ¹⁵ / ₁₆ "		1.75 lbs.	C04511
14012	hold open	24" - 29 ¹⁵ / ₁₆ "		1.8 lbs.	C04511
14013	hold open	30" - 35 ¹⁵ / ₁₆ "	32" - 37 ¹⁵ / ₁₆ "	1.8 lbs.	C04511
14014	hold open	36" - 48"	38" - 48"	2.0 lbs.	C04511
14021	stop only	18" - 23 ¹⁵ / ₁₆ "		1.75 lbs.	C04541
14022	stop only	24" - 29 ¹⁵ / ₁₆ "		1.8 lbs.	C04541
14023	stop only	30" - 35 ¹⁵ / ₁₆ "	32" - 37 ¹⁵ / ₁₆ "	1.8 lbs.	C04541
14024	stop only	36" - 48"	38" - 48"	2.0 lbs.	C04541
14031	friction	18" - 23 ¹⁵ / ₁₆ "		1.75 lbs.	C04531
14032	friction	24" - 29 ¹⁵ / ₁₆ "		1.8 lbs.	C04531
14033	friction	30" - 35 ¹⁵ / ₁₆ "	32" - 37 ¹⁵ / ₁₆ "	1.8 lbs.	C04531
14034	friction	36" - 48"	38" - 48"	2.0 lbs.	C04531

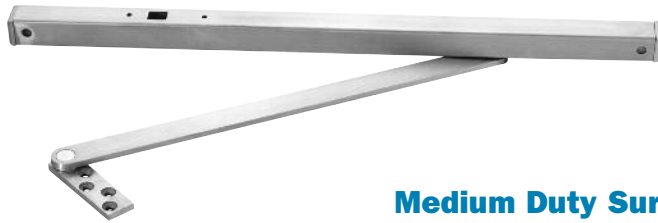

**Medium Duty Surface Mounted
 14400 Series**

Material: Stainless Steel

Finishes: US32D (other BHMA finishes are available upon request)

Fastener: Wood Door Jamb: 4 ea. #10 x 1½ FH WS
 Wood Door: 2 ea. 10 x 32 x 1½ RH MS;
 2 ea. 10-32 x 1⅝ Sex Bolt

Metal Door Jamb: 4 ea. 10-32 x ½ FH MS
 Metal Door: 2 ea. 10 x 32 x 1½ RH MS;
 2 ea. 10-32 x 1⅝ Sex Bolt

Ordering:

- Indicate model number, finish, conflicting hardware, mounting means of the door, door opening, and thickness.
- **All stainless steel components add Prefix N.**

Other:

- For interior single acting doors.
- Maximum opening 110°, minimum door thickness 1⅜".

No.	Function	Door Opening		Weight	ANSI A156.8
		Butts/Offset Pivots	Center Hung		
14411	hold open	18" - 23 ¹⁵ / ₁₆ "	22" - 27 ⁷ / ₁₆ "	1.8 lbs.	C05511
14412	hold open	24" - 29 ¹⁵ / ₁₆ "	27½" - 33 ⁷ / ₁₆ "	1.8 lbs.	C05511
14413	hold open	30" - 35 ¹⁵ / ₁₆ "	33½" - 38 ¹⁵ / ₁₆ "	2.0 lbs.	C05511
14414	hold open	36" - 48"	39" - 48"	2.0 lbs.	C05511
14421	stop only	18" - 23 ¹⁵ / ₁₆ "	22" - 27 ⁷ / ₁₆ "	1.8 lbs.	C05541
14422	stop only	24" - 29 ¹⁵ / ₁₆ "	27½" - 33 ⁷ / ₁₆ "	1.8 lbs.	C05541
14423	stop only	30" - 35 ¹⁵ / ₁₆ "	33½" - 38 ¹⁵ / ₁₆ "	2.0 lbs.	C05541
14424	stop only	36" - 48"	39" - 48"	2.0 lbs.	C05541
14431	friction	18" - 23 ¹⁵ / ₁₆ "	22" - 27 ⁷ / ₁₆ "	1.8 lbs.	C05531
14432	friction	24" - 29 ¹⁵ / ₁₆ "	27½" - 33 ⁷ / ₁₆ "	1.8 lbs.	C05531
14433	friction	30" - 35 ¹⁵ / ₁₆ "	33½" - 38 ¹⁵ / ₁₆ "	2.0 lbs.	C05531
14434	friction	36" - 48"	39" - 48"	2.0 lbs.	C05531



**Heavy Duty Surface Mounted
17000 Series**

Material: Steel

Finishes: US26D (other BHMA finishes are available upon request)

Fastener: Wood Door Jamb: 4 ea. #14 x 1½ FH WS
 Wood Door: 2 ea. ¼-20 x 2 FH MS;
 2 ea. ¼-20 Grommet Nut;
 1 ea. #14 x 1½ FH WS

Metal Door Jamb: 4 ea. ¼-20 x ¾ FH MS
 Metal Door: 3 ea. ¼-20 x ¾ TH MS

Ordering: • Indicate model number, finish, conflicting hardware, mounting means of the door, door opening, and thickness.

• **All stainless steel components add Prefix N.**

Other: • For exterior, vestibule and interior single acting doors.
 • Maximum door opening 110°, minimum door thickness 1¼".

Features: Wood, machine screws and grommet nuts included.

Door Opening

No.	Function	Door Opening		Weight	ANSI A156.8
		Butts/Offset Pivots	Center Hung		
17010	hold open	23" - 28 ¹⁵ / ₁₆ "	24" - 31 ¹⁵ / ₁₆ "	2.5 lbs.	C08511
17011	hold open	29" - 34 ¹⁵ / ₁₆ "	32" - 38 ⁷ / ₁₆ "	2.5 lbs.	C08511
17012	hold open	35" - 40 ¹⁵ / ₁₆ "	38½" - 44 ³ / ₁₆ "	2.7 lbs.	C08511
17013	hold open	41" - 46 ¹⁵ / ₁₆ "	44¼" - 50 ³ / ₁₆ "	2.7 lbs.	C08511
17014	hold open	47" + Greater	50¼" - 60"	2.9 lbs.	C08511
17020	stop only	23" - 28 ¹⁵ / ₁₆ "	24" - 31 ¹⁵ / ₁₆ "	2.5 lbs.	C08541
17021	stop only	29" - 34 ¹⁵ / ₁₆ "	32" - 38 ⁷ / ₁₆ "	2.5 lbs.	C08541
17022	stop only	35" - 40 ¹⁵ / ₁₆ "	38½" - 44 ³ / ₁₆ "	2.7 lbs.	C08541
17023	stop only	41" - 46 ¹⁵ / ₁₆ "	44¼" - 50 ³ / ₁₆ "	2.7 lbs.	C08541
17024	stop only	47" + Greater	50¼" - 60"	2.9 lbs.	C08541



**Heavy Duty Surface Mounted
 1900 Series**

Material: Stainless Steel

Finishes: US32D (other BHMA finishes are available upon request)

Fastener: Wood Door Jamb: 4 ea. #14 x 1½ FH WS
 Wood Door: 2 ea. 5/16-18 x 2 RH MS;
 2 ea. 5/16-18 x 1½ Sex Bolt

Metal Door Jamb: 4 ea. ¼-20 x ¾ FH MS
 Metal Door: 2 ea. 5/16-18 x 2 RH MS;
 2 ea. 5/16-18 x 1½ Sex Bolt

Ordering:

- Indicate model number, finish, conflicting hardware, mounting means of the door, door opening, and thickness.
- **All stainless steel components add Prefix N.**

Other:

- For exterior, vestibule and interior single acting doors.
- Maximum door opening 110°, minimum door thickness 1¾".

No.	Function	Door Opening		Weight	ANSI A156.8
		Butts/Offset Pivots	Center Hung		
19011	hold open	28" - 29 ¹⁵ / ₁₆ "	30" - 33 ¹⁵ / ₁₆ "	5.5 lbs.	C02511
19012	hold open	30" - 31 ¹⁵ / ₁₆ "	34" - 35 ¹⁵ / ₁₆ "	5.7 lbs.	C02511
19013	hold open	32" - 35 ¹⁵ / ₁₆ "	36" - 38 ¹⁵ / ₁₆ "	6.0 lbs.	C02511
19014	hold open	36" - 39 ¹⁵ / ₁₆ "	39" - 40 ¹⁵ / ₁₆ "	6.4 lbs.	C02511
19015	hold open	40" - 41 ¹⁵ / ₁₆ "	41" - 44 ¹⁵ / ₁₆ "	6.6 lbs.	C02511
19016	hold open	42" - 43 ¹⁵ / ₁₆ "	45" - 46 ¹⁵ / ₁₆ "	6.7 lbs.	C02511
19017	hold open	44" + Greater	47" + Greater	6.8 lbs.	C02511
19021	stop only	28" - 29 ¹⁵ / ₁₆ "	30" - 33 ¹⁵ / ₁₆ "	5.5 lbs.	C02541
19022	stop only	30" - 31 ¹⁵ / ₁₆ "	34" - 35 ¹⁵ / ₁₆ "	5.7 lbs.	C02541
19023	stop only	32" - 35 ¹⁵ / ₁₆ "	36" - 38 ¹⁵ / ₁₆ "	6.0 lbs.	C02541
19024	stop only	36" - 39 ¹⁵ / ₁₆ "	39" - 40 ¹⁵ / ₁₆ "	6.4 lbs.	C02541
19025	stop only	40" - 41 ¹⁵ / ₁₆ "	41" - 44 ¹⁵ / ₁₆ "	6.6 lbs.	C02541
19026	stop only	42" - 43 ¹⁵ / ₁₆ "	45" - 46 ¹⁵ / ₁₆ "	6.7 lbs.	C02541
19027	stop only	44" + Greater	47" + Greater	6.8 lbs.	C02541
19031	friction	28" - 29 ¹⁵ / ₁₆ "	30" - 33 ¹⁵ / ₁₆ "	5.5 lbs.	C02531
19032	friction	30" - 31 ¹⁵ / ₁₆ "	34" - 35 ¹⁵ / ₁₆ "	5.7 lbs.	C02531
19033	friction	32" - 35 ¹⁵ / ₁₆ "	36" - 38 ¹⁵ / ₁₆ "	6.0 lbs.	C02531
19034	friction	36" - 39 ¹⁵ / ₁₆ "	39" - 40 ¹⁵ / ₁₆ "	6.4 lbs.	C02531
19035	friction	40" - 41 ¹⁵ / ₁₆ "	41" - 44 ¹⁵ / ₁₆ "	6.6 lbs.	C02531
19036	friction	42" - 43 ¹⁵ / ₁₆ "	45" - 46 ¹⁵ / ₁₆ "	6.7 lbs.	C02531
19037	friction	44" + Greater	47" + Greater	6.8 lbs.	C02531

ROCKWOOD

ASSA ABLOY

**E - Bolts and Latches
from Rockwood**

Bolts and Latches

UL Listed

Proven Durability

Smooth Action

Beautiful Finishes

ASSA ABLOY, the global leader
in door opening solutions



Lever Extension Flush Bolt (Fire Rated Hollow Metal Swinging Doors measuring up to 4'w x 10'h rated up to and including 3 hours.)

No. 550

Material: Brass

Finishes: Available in standard architectural finishes (see page 7).

Fastener: 8 ea. #8 x 3/4 FH Combo Screws

Features:

- 3/4" bolt throw, 3/4" rod backset.
- 12" rod length (center of face to bolt end - retracted).
- 1 1/2" adjustable bolt head.

Options:

- Other size rods available are 18", 24", 36", 48".
- Use #570 Dust Proof Strike (shown on page E3) to prevent dirt blocking bottom strike.

No.	Size	Weight	ANSI A156.16
550	Face Plate: 1 1/4" x 6 3/4" Strike: 1 5/16" x 2 1/4" Guide: 1" x 2"	1.7 lbs./2	L04251

Rabbit Piece

No. 554



Material: Brass

Finishes: Available in standard architectural finishes (see page 7).

Fastener: 2 ea. #8 x 1 1/4 FH WS

Other: For use on rabbeted doors to fill mortise cut.

No.	Size	Weight	ANSI A156.16
554	1/2" x 6 3/4"	4.1 lbs./10	w/555 L04101

Rabbit Guides

No. 554G, 554S

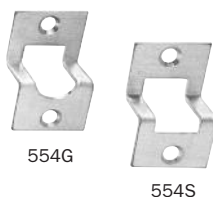

Material: Brass

Finishes: Brass

Fastener: 2 ea. #8 x 3/4 FH Combo Screws

Lever Extension Flush Bolt (Fire Rated Hollow Metal Swinging Doors measuring up to 4'w x 10'h rated up to and including 3 hours.)

No. 555

Material: Brass

Finishes: Available in standard architectural finishes (see page 7).

Fastener: 8 ea. #8 x 3/4 FH Combo Screws

- Features:**
- Fits ANSI A115 door and frame preparation.
 - 3/4" bolt throw, 3/4" rod backset.
 - 12" rod length (center of face to bolt end - retracted).
 - 1 1/2" adjustable bolt head.

- Options:**
- Other size rods available are 18", 24", 36", 48".
 - Extra long bolt head - 2 1/2" (or to your specification).
 - Use #570 Dust Proof Strike (shown on page E3) to prevent dirt blocking bottom strike.

No.	Size	Weight	ANSI A156.16
555	Face Plate: 1" x 6 3/4" Strike: 1 5/16" x 2 1/4" Guide: 1" x 2"	1.5 lbs./2	L04251



Lever Extension Flush Bolt With Bottom Fire Bolt (Fire Rated Hollow Metal Swinging Doors measuring up to 4'w x 9'h rated up to and including 3 hours.)

No. 555 x 18BFB

Material: Flush Bolt - Brass
Bottom Fire Bolt - Stainless Steel

Finishes: Available in standard architectural finishes (see page 7).

Fastener: 8 ea. #8 x 3/4 FH Combo Screws

- Features:**
- Fits ANSI A115 door and frame preparation.
 - 3/4" bolt throw, 3/4" rod backset.
 - 12" rod length (center of face to bolt end - retracted).
 - 1 1/2" adjustable bolt head.
 - When door is subjected to 230°F the plug and black plastic cover will melt allowing the bolt to project, locking the leaves together.
 - Bottom fire bolt eliminates need for floor prep.
 - Oversize fire bolt strike hole allows for slight door misalignment.

- Options:**
- Other size rods available are 18", 24", 36", 48".
 - Extra long bolt head - 2 1/2" (or to your specification).

No.	Size	Weight
555 x 18BFB	Top Bolt: 1" x 6 3/4" Bottom Bolt: 1 3/16" dia.	0.9 lbs.





Lever Extension Flush Bolt (Fire Rated Plastic & Wood covered fire doors measuring up to 4'w x 10'h rated up to and including 1-1/2 hours.)

No. 557

Material: Cast Brass

Finishes: Available in standard architectural finishes (see page 7).

Fastener: 7 ea. #8 x 3/4 FH Combo Screws
4 ea. 8-32 x 1/2 FH MS
4 ea. #8 Counter Sunk Washer

Features: 3/4" bolt throw, 3/4" backset; door strength maintained by corner reinforcing plate.

Options: Use #570 Dust Proof Strike (shown on page E3) to prevent dirt blocking bottom strike.

No.	Size	Weight	ANSI A156.16
557	Face Plate: 1" x 6 3/4" Strike: 1 5/16" x 2 1/4"	1.7 lbs./2	L04261



Lever Extension Flush Bolt With Bottom Fire Bolt (Fire Rated Plastic & Wood covered fire doors measuring up to 4'w x 9'h rated up to 20 minutes.)

No. 557 x 19BFB

Material: Flush Bolt - Brass
Bottom Fire Bolt - Stainless Steel

Finishes: Available in standard architectural finishes (see page 7).

Fastener: 7 ea. #8 x 3/4 FH Combo Screws
4 ea. 8-32 x 1/2 FH MS
4 ea. #8 Counter Sunk Washer

Features:

- 3/4" bolt throw, 3/4" backset; door strength maintained by corner reinforcing plate.
- When door is subjected to 230°F the plug and black plastic cover will melt allowing the bolt to project, locking the leaves together.
- Bottom fire bolt eliminates need for floor prep.
- Oversize fire bolt strike hole allows for slight door misalignment.

No.	Size	Weight
557 x 19BFB	Top Bolt: 1" x 6 3/4" Bottom Bolt: 1 3/16" dia.	0.9 lbs.



**Dust Proof Strike
 No. 570**



- Material:** Brass
- Finishes:** Available in standard architectural finishes (see page 7).
- Fastener:** Adjustment Nut;
 Spanner Wrench;
 2 ea. #8 x 1 OH SMS, 2 ea. Plastic Anchors;
 2 ea. 8-32 x 3/4 OH MS, 2 ea. Lead Anchors
- Features:**
- Works with all Rockwood manual and automatic flush bolts.
 - Removable face plate for use with thresholds.
 - Adjustable height for carpeted areas.

No.	Size	Weight	ANSI A156.16
570	Face Plate: 1 3/8" x 2 7/8" Barrel: 7/8" dia. x 2" depth	0.4 lbs.	L04021

**Gravity Door Coordinator
 No. 576**

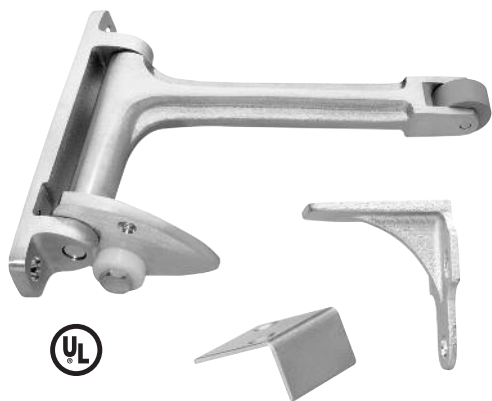

- Material:** Cast Brass
- Finishes:** Available in standard architectural finishes (see page 7).
- Fastener:** Body - 2 ea. #10 x 1 FH SMS, 2 ea. 10-24 x 1 FH MS
 Strike - 5 ea. #8 x 1 FH SMS
- Other:**
- For use on door sizes:
 - with Astragal on active door - 18" to 48"
 - with Astragal on inactive door - 18" to 34"
 - with Astragal on both doors - 18" to 30"
 - The overlap of the astragal is maximum 7/8" with door hung on standard hinges. Customer must contact the factory for all other astragal situations.
- Features:** Non-handed reversible. Prevents the active door from closing until the inactive door is closed.

No.	Size	Projection	Weight	ANSI A156.3
576	1" x 5 7/16"	7"	2.2 lbs.	Type 21

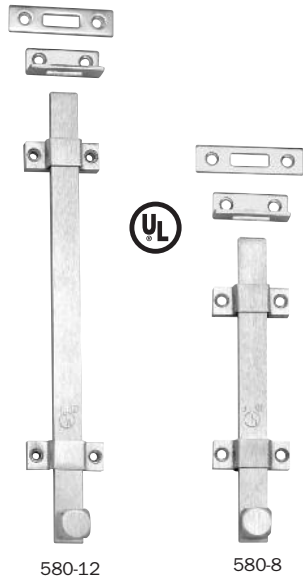

580-12

580-8

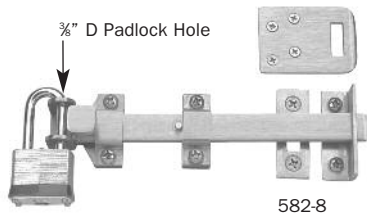

582-8

**Surface Bolts
No. 580, 582 Series**

Material: No. 580: Steel, Stainless Steel
No. 582: Stainless Steel

Finishes: US3, US10, US10B Painted, US26D, US32D

Fastener: No. 580: 8 ea. #10 x 1¼ FH SMS, 8 ea. 10-24 x 1 FH MS
No. 582: Bolt: 4 ea. 10-24 x 1½ PH MS; 4 ea. #10 x 1¼ PH WS
Strikes: 6 ea. 10-32 x 1½ FH MS; 6 ea. 10-32 x 1½ FH WS

Other: 1⅛" bolt throw, ¼" x ¾" bolt material.

Features:

- **No. 580 series bolts are UL listed** for use on inactive leaf of a pair of 3-hour labeled fire doors.
- No. 580 and No. 582 series both include a universal top strike and a mortise bottom strike.
- No. 582 series has a bracket for padlock (*padlock not included*).

Options: Sex bolts available for extra secure mounting.

No.	Bolt Length	Weight	ANSI A156.16
580-8	8"	1.1 lbs.	L04161
580-12	12"	1.4 lbs.	L04161
580-18	18"	1.7 lbs.	L04161
580-24	24"	2.0 lbs.	L04161
582-8	8"	1.3 lbs.	
582-12	12"	1.6 lbs.	

**Heavy Duty Surface Bolts
No. 585 Series**

Material: Steel

Finishes: US26D

Fastener: Bolt: 4 ea. ¼-20 x 2¼ FH MS;
4 ea. ¼-20 x 1⅝ Sex Bolts
Strike: 2 ea. #14 x 2½ FH SMS, 2 ea. Plastic Anchors;
2 ea. ¼-20 x 1 FH MS, 2 ea. ¼-20 Lead Anchors

Other: 1¼" bolt throw, ¾" x ¾" bolt material.

Features:

- UL listed for use on inactive leaf of a pair of 3-hour labeled fire doors.
- Includes a universal top strike and a mortise bottom strike.
- Locks in both the up and down position.
- Bolt locks automatically when thrown; can be released only by pressing knob toward door while retracting.
- Can be used on any type of door.
- Accommodates padlock.

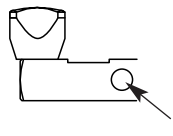

3/8" D Padlock Hole

No.	Bolt Length	Weight	ANSI A156.16
585-12	12"	3.9 lbs.	L04161
585-24	24"	6.1 lbs.	L04161

**Roller Latch with Cast Strike
 No. 590**

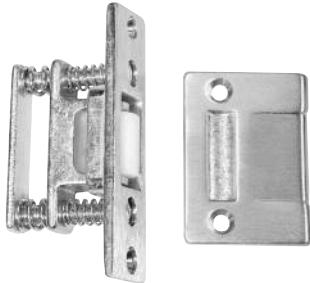

Material: Cast Brass

Finishes: Available in standard architectural finishes (see page 7).

Fastener: Body: 2 ea. #8 x 3/4 FH Combo Screws
 Strike: 2 ea. #8 x 3/4 FH Combo Screws

Features: • Solid nylon roller for durable silent operation.
 • Simple adjustment for roller projection.

No.	Latch Face	Strike	Weight	ANSI A156.16
590	1" x 3 3/8"	1 11/16" x 2 1/4"	0.6 lbs.	E09091

**Roller Latch with Double Acting Strike
 No. 590DA**

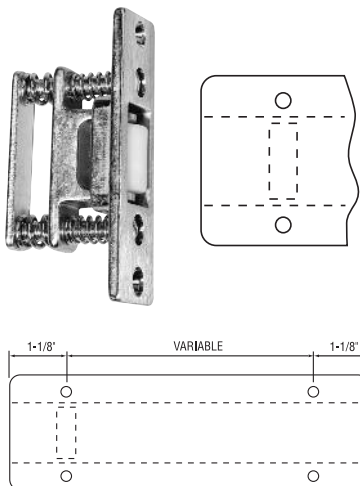

Material: Brass

Finishes: Available in standard architectural finishes (see page 7).

Fastener: Body: 2 ea. #8 x 3/4 FH Combo Screws
 Strike: 4 ea. #8 x 3/4 FH Combo Screws

Other: For use on double acting doors and frames with the No. 590. Specify size required.

Features: • Solid nylon roller for durable silent operation.
 • Simple adjustment for roller projection.

No.	Latch Face	Strike	Weight
590DA	1" x 3 3/8"	2 3/4" x specify	0.6 lbs.

**Roller Latch with ASA Strike
 No. 591**

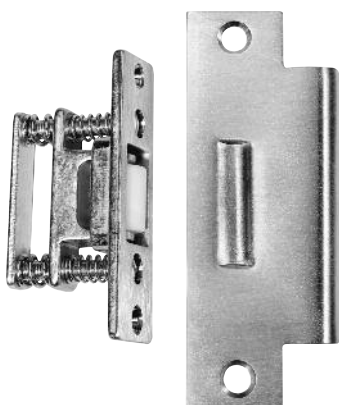

Material: Cast Brass

Finishes: Available in standard architectural finishes (see page 7).

Fastener: Body: 2 ea. #8 x 3/4 FH Combo Screws
 Strike: 2 ea. 12-24 x 1/2 FH MS

Features: • Solid nylon roller for durable silent operation.
 • Simple adjustment for roller projection.

No.	Latch Face	Strike	Weight
591	1" x 3 3/8"	1 1/4" x 4 7/8"	0.6 lbs.

**Roller Latch with #161 Strike
No. 592**

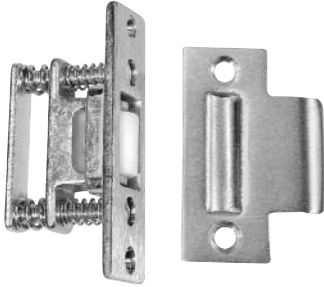

Material: Cast Brass

Finishes: Available in standard architectural finishes (see page 7).

Fastener: Body: 2 ea. #8 x 3/4 FH Combo Screws
Strike: 2 ea. #8 x 3/4 FH Combo Screws

Features: • Solid nylon roller for durable silent operation.
• Simple adjustment for roller projection.

No.	Latch Face	Strike	Weight
592	1" x 3 3/8"	1 1/8" x 2 3/4"	0.6 lbs.

**Roller Latch with Angle Stop
No. 593**

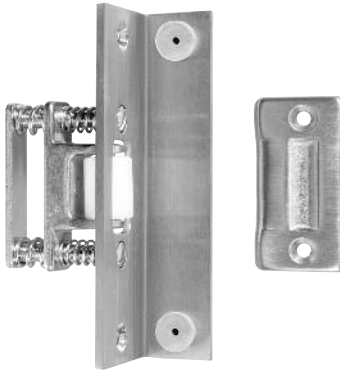

Material: Cast Brass

Finishes: Available in standard architectural finishes (see page 7).

Fastener: Body: 2 ea. #12 x 1 1/2 FH WS
Strike: 2 ea. #8 x 3/4 FH Combo Screws

Features: • Mounts in header with strike in top of door.
• Solid nylon roller for durable silent operation.
• Simple adjustment for roller projection.

No.	Latch Face	Strike	Projection	Weight	ANSI A156.16
593	1 1/2" x 4 1/2"	1 1/8" x 2 1/4"	5/8"	0.8 lbs.	E09111

**Roller Latch with #161 Strike
No. 594**

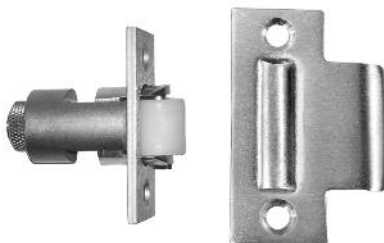

Material: Cast Brass

Finishes: Available in standard architectural finishes (see page 7).

Fastener: Body: 2 ea. #8 x 3/4 FH Combo Screws
Strike: 2 ea. #8 x 3/4 FH Combo Screws

Features: • Solid nylon roller for durable silent operation.
• Simple adjustment for roller projection.

No.	Latch Face	Strike	Weight
594	1 1/8" x 2 1/4"	1 1/8" x 2 3/4"	0.7 lbs.



Hospital Push Pull Latch

No. 596, 596 ASA, 596S, 596S ASA, 596CK-T, 596CK-ASA

Material: Stainless Steel

Finishes: US32D, other finishes available on special order.

- Features:**
- Non-handed (except for engraved models).
 - Standard or ASA strike.
 - 2¾" or 5" backset.
 - UL listed for all fire doors.
 - Compact 2¾" x 4½" covers.
 - Handle projection 2¾".
 - Five mounting positions.

- Options:**
- Engraved "PUSH" or "PULL".
 - Lead lined.
 - 596CK - Conversion Kit (scalp & strike only) to convert roller latch installation to hospital latch.

No.	Fastener	Backset	Escutcheon	Strike	Weight
596	Body: 4 ea. ¼-20 x 2½ TH MS, 4 ea. lock nuts Backset: 2 ea. #8 x ¾ FH WS Strike: 2 ea. #8 x ¾ FH WS	5"	2¾" x 4½"	1½" x 2¾"	5.2 lbs./set
596S	Body: 4 ea. ¼-20 x 2½ TH MS, 4 ea. lock nuts Backset: 2 ea. #8 x ¾ FH WS Strike: 2 ea. #8 x ¾ FH WS	2¾"	2¾" x 4½"	1½" x 2¾"	5.2 lbs./set
596 ASA	Body: 4 ea. ¼-20 x 2½ TH MS, 4 ea. lock nuts Backset: 2 ea. #8 x ¾ FH WS Strike: 2 ea. #12-24 x ¾ FH MS	5"	2¾" x 4½"	1¼" x 4⅞"	5.2 lbs./set
596S ASA	Body: 4 ea. ¼-20 x 2½ TH MS, 4 ea. lock nuts Backset: 2 ea. #8 x ¾ FH WS Strike: 2 ea. #12-24 x ¾ FH MS	2¾"	2¾" x 4½"	1¼" x 4⅞"	5.2 lbs./set
596CK-T	Conversion Kit only (2¾" strike)				
596CK-ASA	Conversion Kit only (4⅞" strike)				

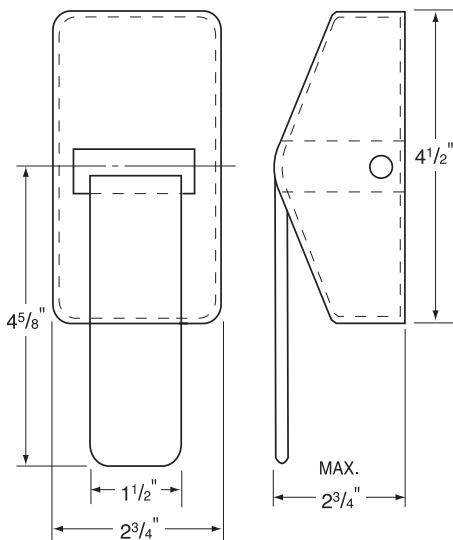

Mounting Positions

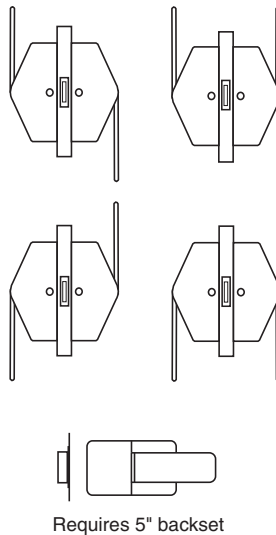

596CK-T
Roller latch to hospital latch conversion kit.

**Secret Gate Latch
No. 602**



Material: Cast Brass

Finishes: US4, US10, US10B, US26D

Features: • Single acting, reversible. Supplied with dummy knob.
• Bolt activated by pressing button concealed on bottom of latch case.

No.	Fastener	Size	Weight
602	5 ea. #7 x 1¼ OH WS	Case: 2" x 2¾" Strike: 2" x 2¾"	3.4 lbs./6

**Door Guard
No. 603**

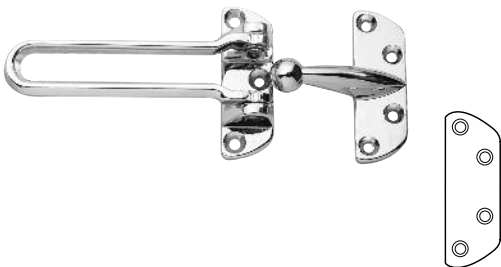

Material: Cast Aluminum

Finishes: Antique Brass (ANT), Bright Brass (BRS), Bright Chrome (CRM)

Options: ⅛" clear plastic shim - order separately as 603 SHIM.

No.	Fastener	Size	Weight	ANSI A156.16
603	Body: 3 ea. #6 x 1½ FH SMS Strike: 4 ea. #6 x 1 FH SMS	Body: 29/32" x 2½" Strike: 31/32" x 2½"	4.2 lbs./10	L33042
603 SHIM		3½" x 2½"		

**Door Guard
No. 604**



Material: Solid Cast Brass

Finishes: US3, US4, US10, US10B, US26, US26D

Options: ⅛" clear plastic shim - order separately as 604 SHIM.

No.	Fastener	Size	Weight	ANSI A156.16
604	Body: 3 ea. #6 x 1½ OH SMS Strike: 4 ea. #6 x ¾ OH SMS	Body: 1½" x 29/16" Strike: 1½" x 1½"	4.4 lbs./10	L13042
604 SHIM		1½" x 1½"		

**Door Guard Protection Plates
No. 605, 605SMS**



Material: Brass

Finishes: US3, US4, US5, US10, US10B, US26, US26D

Features: Protects corner of door from damage by door guard arm.

No.	Fastener	Size	Weight
605	self-adhesive tape	1½" x 1" x ½" return	0.3 lbs./10
605SMS	#6 x 5/8 FHSMS	1½" x 1" x ½" return	0.3 lbs./10

Door Guards & Silencers

**Wall Guard
 No. 606**

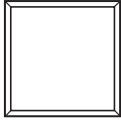

Material: Clear Rubber
Other: Sold in sheets of 55.
Features: Self-adhesive mounting.

No.	Fastener	Size	Weight
606	self-adhesive back	1" x 1"	0.4 lbs./55

**Privacy Door Latch
 No. 607**

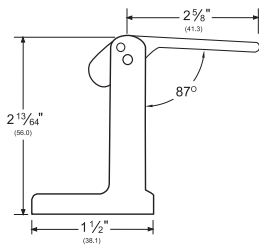
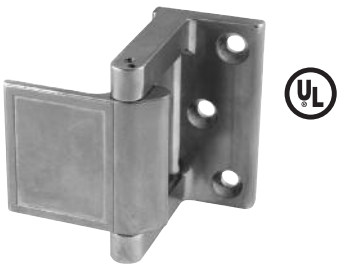

Material: Zinc Die Cast
Finishes: BRS, DBRS, STNN, CRM, DCRM, ORB
Features:

- ADA compliant.
- Enhanced in room privacy.
- Easy to install.
- For use with UL Classified fire doors for use with hollow metal steel composite type fire doors rated up to and including 3 hrs. Wood composite type fire doors rated up to and including 1½ hrs and 20 minutes without hose stream.

No.	Fastener	Size	Weight
607	#12 x 1¼" FHMS	1½" x 2 ¹³ / ₆₄ "	0.75 lbs.

**Door Silencer
 No. 608CA**

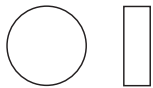

Material: Clear Rubber
Other: Sold in packages of 300.
Features: Self-adhesive mounting.

No.	Fastener	Size	Weight
608CA	3/8" dia. x 1/8"	metal or wood	0.2 lbs./300

**Door Silencers
 No. 608, 609**



608



609

Material: DuraFlex Gray Rubber
Other: Sold in packages of 100.

No.	Size	Frame Type	Weight	ANSI A156.16
608	½" dia. x 5/8"	metal	1.3 lbs./500	L03011
609	3/8" x 3/4"	wood	1.3 lbs./500	L03021

Surface & Flush Bolts

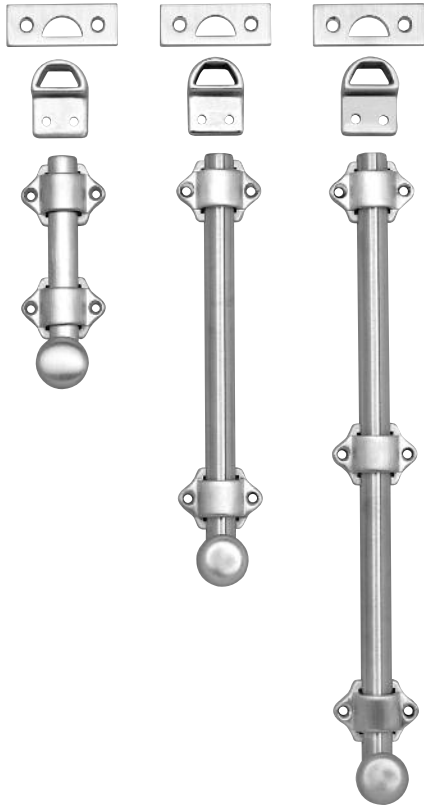

**Surface Bolts
No. 630 Series**

Material: Solid Brass

Finishes: US3, US10B, US26D (other finishes available on special order)

- Features:**
- Unique fiber gasket provides slide resistance without marring surface of bolt.
 - 1" diameter knob.
 - Supplied with universal and mortise strike.

No.	Fastener	Overall Size	Bolt Size	Bolt Length	Bolt Throw	Guides	Weight
630-4	8 ea. #6 x 3/4 OH SMS	1 5/8" x 4 3/8"	5/8" half round	4"	9/16"	2	2.5 lbs./5
630-8	8 ea. #6 x 5/8 OH SMS	1 5/8" x 8"	5/8" half round	8"	9/16"	2	3.9 lbs./5
630-12	10 ea. #6 x 5/8 OH SMS	1 5/8" x 12"	5/8" half round	12"	9/16"	3	5.3 lbs./5
630-24	12 ea. #6 x 5/8 OH SMS	1 5/8" x 24"	5/8" half round	24"	9/16"	4	11.8 lbs./5



**Residential Flush Bolts
No. 640, 640RE**

Material: Wrought Brass

Finishes: US3, US5, US26D

- Features:** Spring action holds the bolt in either projected or retracted position.

No.	Fastener	Overall Size	Bolt Size	Bolt Throw	Guides	Weight
640	4 ea. #6 x 3/4 FH SMS	3/4" x 6"	1/2" dia.	15/16"	7/8" x 2"	1.5 lbs./5
640RE	4 ea. #6 x 3/4 FH SMS	3/4" x 6"	1/2" dia.	15/16"	7/8" x 2"	1.5 lbs./5

1600 Series Door Coordinators

Material: Steel

Finishes: Black Prime Coat, US28 (689)

Fastener: 7 ea. 12-24 x 1¼ TH Type C Tapping Screws

Size: Standard device size 5/8" x 1 5/8" x 52".

Options: Specify make and model of exit device for vertical rod preparation.

Features: Non-handed. Override protection to prevent damage in case of abnormal force on door. Mechanism and filler bar completely fill width of opening and when painted to match frame it becomes virtually invisible.



Ordering:	Stock Sizes	No.	Opening	Weight	ANSI A156.3
	1660	60"	7.0 lbs.	Type 21A	
	1672	72"	8.0 lbs.	Type 21A	
	1696	96"	9.75 lbs.	Type 21A	

Custom Sizes — The 1600 Series coordinators are manufactured in different housing lengths to coordinate the full range of door sizes:

- **NX1600 Series:** For jamb opening widths (A + B dimension) from 48" - 54". E dimension, 42".
- **1600 Series:** For jamb opening widths (A + B dimension) from 54" - 96". E dimension, 52".
- **L1600 Series:** For unusual widths and special conditions. E dimension, 60".

Determining Coordinator Item Number

- Active door widths A plus inactive door width B equals the last two or three digits of all 1600 Series coordinator item numbers; i.e., 1680 is for 80" door opening.
- Less than 48" jamb widths = N1600 series; i.e., N1644 = 44" opening.
- Larger sizes are available (XL, XXL), contact the factory.

NOTE: Some panic hardware requires the coordinator to be factory prepped. Contact factory.

No.	Jamb Widths	Coordinator Length	ANSI A156.3
NX1648 - NX1654	48" - 54"	42"	Type 21A
1655 - 1660	55" - 60"	52"	Type 21A
1661 - 1672	61" - 72"	52"	Type 21A
1673 - 1696	73" - 96"	52"	Type 21A
L1662 - L16112	62" - 112" (active doors over 48")	60"	Type 21A

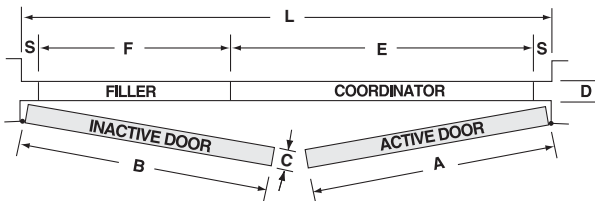

Fillers are usually supplied precut from the factory (filler bars shown on page E12).

NOTE: If "S" dimension is other than 5/8" advise the factory.

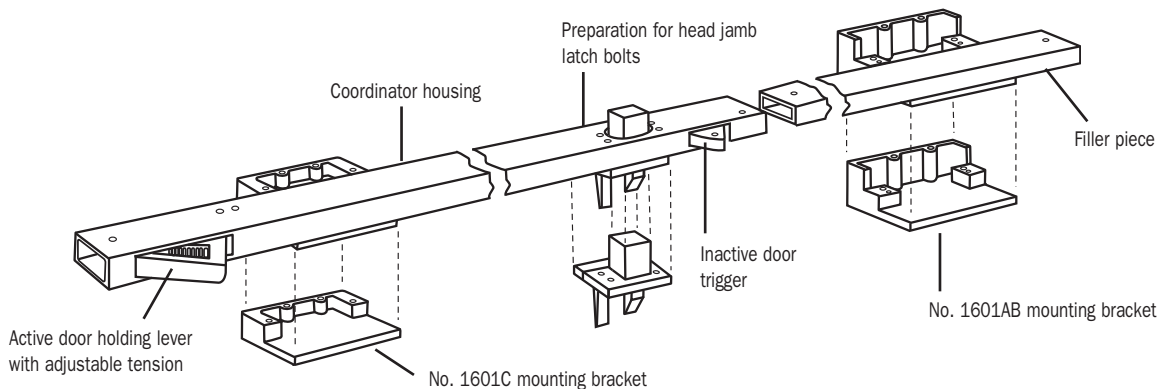



**Carry Bar for #1600 Series Coordinator
No. 1100**

Material: Brass, Steel

Finishes: US3, US4, US10, US10B, US26, US26D, and Black Prime Coat

Fastener: 2 ea. ¼-20 x 1 RH MS, 2 ea. ¼-20 x 1¹¹/₁₆ Sex Bolts

Other: A carry bar is used when it is possible to open the inactive door before opening the active door.

No.	Size	Weight
1100	1¾" x 2¼"	0.3 lbs.



**Filler Bar for #1600 Series Coordinator
No. FB-1, FB-2**

Material: Steel

Finishes: Black Prime Coat

Features: Filler bar is supplied no charge with the No. 1600 Series coordinator (shown on page E11).

No.	Size
FB-1	Specify length from 1 ⁵ / ₈ " to 18 ⁵ / ₈ "
FB-2	Specify length from 19 ⁵ / ₈ " to 42 ⁵ / ₈ "

Contact factory for larger sizes.

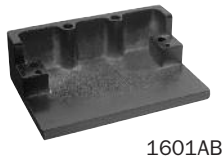

1601AB



1601C

**Mounting Brackets (for Soffit Applied Hardware)
No. 1601AB, 1601C**

Material: Aluminum

Finishes: Black Prime Coat

Fastener: 4 ea. ¼-20 x ½ FH MS, 4 ea. 12-24 x 2 FH MS

Features: Used for stop applied hardware. Prevents the inadvertent disabling of the coordinator by fasteners passing through the housing.

No.	Soffit Size	Length	Weight
1601AB	7/8" - 2¼"	5"	0.9 lbs.
1601C	over 2¼"	5"	0.8 lbs.



**Universal Door Coordinator
No. 1700**

Material: Steel, Aluminum

Finishes: Black Prime Coat

Fastener: 6 ea. #10 x 1¾ TH SMS, 6 ea. 10-32 x 1½ TH MS

Features: For pairs of doors up to 8' wide. Non-handed. Stop mounted; no mounting brackets required for stop mounted hardware.

No.	Overall Size	Weight	ANSI A156.3
1700	1½" x 20 ⁷ / ₈ " x 5/8"	2.8 lbs.	Type 21

NOTE: Not for use with surface vertical panic devices.

Automatic & Combination Flush Bolts

Automatic Flush Bolts

No. 1840 (Automatic Top Bolt Only)

No. 1842 (Set) - for Fire Rated Metal Doors labeled A, B, C, D, & E up to 4'w x 9'h

Material: Brass, Stainless Steel

Finishes: US3, US4, US10, US10B, US26, US26D, US32D

Fastener: **No. 1842:** 20 ea. #8 x 3/4 FH Combo Screws, 4 ea. Plastic Anchors

No. 1840: 10 ea. #8 x 3/4 FH Combo Screws, 2 ea. Plastic Anchors

- Features:**
- Non-handed.
 - Low (5 lbs. maximum) closing force.
 - Fully automatic; opening active door retracts top and bottom bolts.
 - Override feature prevents damage to doors or bolts if bolt heads are blocked from entering strikes.
 - Bolt head rods are adjustable up to 1 1/2".
 - Thermal lock automatically locks the inactive door under high heat conditions due to fire.

Options: No. 1842 can be used with the #570 Dust Proof Strike (shown on page E3).



No.	Size	Weight	ANSI A156.3
1840	1" x 6 3/4"	1.2 lbs.	Type 25
1842	1" x 6 3/4"	2.4 lbs.	Type 25

Combination Flush Bolts

No. 1805 (Self Latching Top Bolt Only)

No. 1845 (Set) - for Fire Rated Metal Doors labeled A, B, C, D, & E up to 4'w x 10'h

Material: Brass, Stainless Steel

Finishes: US3, US4, US10, US10B, US26, US26D, US32D

Fastener: **Top** - 8 ea. #8 x 3/4 FH Combo Screws, 2 ea. Plastic Anchors

Bottom (No. 1845 only) - 10 ea. #8 x 3/4 FH Combo Screws, 2 ea. Plastic Anchors

- Features: Top Bolt**
- Automatically engages when the inactive door closes. When the active door is opened, the inactive door stays latched at the top until the top bolt is released by pressing the plunger button on the bolt face.

Bottom Bolt (No. 1845 only)

- Non-handed.
- Low (5 lbs. maximum) closing force.
- Fully automatic; opening active door retracts bottom bolt.
- Override feature prevents damage to door or bolt if bolt head is blocked from entering strike.
- Bolt head rod is adjustable up to 1 1/2".
- Thermal lock automatically locks the inactive door under high heat conditions due to fire.

Options: No. 1845 can be used with the #570 Dust Proof Strike (shown on page E3).



No.	Size	Weight	ANSI A156.3
1805	1" x 6 3/4"	1.2 lbs.	Type 27
1845	1" x 6 3/4"	2.4 lbs.	Type 27

Automatic & Combination Flush Bolts



Automatic Flush Bolt

No. 1940 (Automatic Top Bolt Only)

No. 1942 (Set) - for Wood Doors labeled B, C, D, & E up to 4'w x 9'h

Material: Brass, Stainless Steel

Finishes: US3, US4, US10, US10B, US26, US26D, US32D

Fastener: **No. 1940:** 8 ea. #8 x 3/4 FH Combo Screws, 3 ea. Plastic Anchors; 6 ea. #10 x 1 FH WS
No. 1942: 16 ea. #8 x 3/4 FH Combo Screws, 2 ea. Plastic Anchors; 6 ea. #10 x 1 FH WS

- Features:**
- Non-handed.
 - Low (5 lbs. maximum) closing force.
 - Fully automatic; opening active door retracts top and bottom bolts.
 - Override feature prevents damage to doors or bolts if bolt heads are blocked from entering strikes.
 - Bolt head rods are adjustable up to 1/2".
 - Thermal lock automatically locks the inactive door under high heat conditions due to fire.

Options: No. 1942 can be used with the #570 Dust Proof Strike (shown on page E3).

No.	Size	Weight	ANSI A156.3
1940	1" x 8 1/2"	1.5 lbs.	Type 25
1942	1" x 8 1/2"	2.9 lbs.	Type 25

Combination Flush Bolts

No. 1905 (Self Latching Top Bolt Only)

No. 1945 (Set) - for Wood Doors labeled B, C, D, & E up to 4'w x 9'h



Material: Brass, Stainless Steel

Finishes: US3, US4, US10, US10B, US26, US26D, US32D

Fastener: **Top** - 6 ea. #8 x 3/4 FH Combo Screws, 2 ea. Plastic Anchors, 3 ea. #10 x 1 FH WS
Bottom (No. 1945 only) - 8 ea. #8 x 3/4 FH Combo Screws, 2 ea. Plastic Anchors, 3 ea. #10 x 1 FH WS

- Features: Top Bolt**
- Automatically engages when the inactive door closes. When the active door is opened, the inactive door stays latched at the top until the top bolt is released by pressing the plunger button on the bolt face.

Bottom Bolt (No. 1945 only)

- Non-handed.
- Low (5 lbs. maximum) closing force.
- Fully automatic; opening active door retracts bottom bolt.
- Override feature prevents damage to door or bolt if bolt head is blocked from entering strike.
- Bolt head rod is adjustable up to 1/2".
- Thermal lock automatically locks the inactive door under high heat conditions due to fire.

Options: No. 1945 can be used with the #570 Dust Proof Strike (shown on page E3).

No.	Size	Weight	ANSI A156.3
1905	1" x 8 1/2"	1.5 lbs.	Type 27
1945	1" x 8 1/2"	2.9 lbs.	Type 27

**Automatic Flush Bolt With Bottom Fire Bolt
(for Fire Rated Metal Doors)
No. 1848**



Material: Brass, Stainless Steel

Finishes: US3, US4, US10, US10B, US26, US26D, US32D

Fastener: 10 ea. #8 x 3/4 FH Combo Screws, 4 ea. Plastic Anchors

- Features:**
- Non-handed.
 - Low (5 lbs. maximum) closing force.
 - Fully automatic; opening active door retracts top bolt.
 - Override feature prevents damage to doors or bolt if bolt head is blocked from entering strike.
 - Bolt head rod is adjustable up to 1 1/2".
 - For fire rated metal doors labeled A, B, C, D, & E up to 4'w x 9'h.
 - Thermal lock automatically locks the inactive door under high heat conditions due to fire.
 - Bottom fire bolt eliminates need for floor prep.
 - Oversize fire bolt strike hole allows for slight door misalignment.

No.	Size	Weight
1848	Top Bolt: 1" x 6 3/4" Bottom Bolt: 1 3/16" dia.	1.3 lbs.

**Automatic Flush Bolt With Bottom Fire Bolt
(for Fire Rated Wood Doors)
No. 1948**



Material: Brass, Stainless Steel

Finishes: US3, US4, US10, US10B, US26, US26D, US32D

Fastener: 8 ea. #8 x 3/4 FH Combo Screws, 2 ea. Plastic Anchors;
3 ea. #10 x 1 FH WS

- Features:**
- Non-handed.
 - Low (5 lbs. maximum) closing force.
 - Fully automatic; opening active door retracts top bolt.
 - Override feature prevents damage to doors or bolt if bolt head is blocked from entering strike.
 - Bolt head rod is adjustable up to 1/2".
 - For fire rated UL listed 20-minute wood core and composite doors up to 4'w x 9'h.
 - Thermal lock automatically locks the inactive door under high heat conditions due to fire.
 - Bottom fire bolt eliminates need for floor prep.
 - Oversize fire bolt strike hole allows for slight door misalignment.

No.	Size	Weight
1948	Top Bolt: 1" x 8 1/2" Bottom Bolt: 1 3/16" dia.	1.6 lbs.

**Bottom Fire Bolt (for Metal Doors)
No. 18BFB**



Material: Stainless Steel

Finishes: US32D

Features:

- Eliminates the bottom automatic flush bolt and dust proof strike.
- When door is subjected to 230°F the plug and gray plastic cover will melt allowing the bolt to project, locking the leaves together.
- UL Listed only when used with automatic top bolt.

No.	Size	Weight
18BFB	Bolt: $1\frac{3}{16}$ " x $1\frac{9}{16}$ " Plug: $1\frac{7}{32}$ " dia.	0.1 lbs.

**Cover Plate Kit (for Metal Doors)
No. CPK1840**



Material: Brass

Finishes: US3, US4, US10, US10B, US26, US26D

Fastener: 4 ea. #8 x $\frac{3}{4}$ FH Combo Screws

Features: Covers existing bottom 1840 flush bolt prep.

No.	Cover Plate Size	Weight
CPK1840	1" x $6\frac{3}{4}$ "	0.1 lbs.

**Bottom Fire Bolt (for Wood Doors)
No. 19BFB**



Material: Stainless Steel

Finishes: US32D

Features:

- Eliminates the bottom automatic flush bolt and dust proof strike.
- When door is subjected to 230°F the plug and black plastic cover will melt allowing the bolt to project, locking the leaves together.
- UL Listed only when used with automatic top bolt.

No.	Size	Weight
19BFB	Bolt: $1\frac{3}{16}$ " x $1\frac{9}{16}$ " Plug: $1\frac{13}{64}$ " dia.	0.1 lbs.

Automatic Flush Bolts

**Automatic Flush Bolt With Bottom Fire Bolt
(for Fire Rated Wood Core & Composite Doors)**

No. 1960

Material: Brass

Finishes: US3, US4, US10, US10B, US26, US26D, US32, US32D

Fastener: 4 ea. #8 x 1 FH SMS, 4 ea. 8 x 3/4 FH Combo Screws, 2 ea. Plastic Anchors

- Features:**
- Patent #7,410,195.
 - Durable, tested over 1 million cycles.
 - Smaller profile adds stability to the door.
 - Only two 1 1/8" diameter holes for easier door preparation.
 - Preparation prevents the veneer from splitting at the corners of the door.
 - Quiet & smooth activation.
 - Fully automatic; opening active door retracts top bolt.
 - Non-handed.
 - Override feature prevents damage to doors or bolt if bolt head is blocked from entering strike.
 - Low (3 lbs. maximum) closing force. ADA Compliant.
 - Adjustable Bolt Head Rod: bolts can be vertically adjusted 1/2" for unusual clearances.
 - For up to 4'w x 9'h fire rated wood core & composite doors up to 20 minutes fire rating.



No.	Face Plate Size	Weight
1960	1 1/8" x 2 1/4"	.9 lbs.

**Automatic Flush Bolts (for Fire Rated Wood Core & Composite Doors)
No. 1962**

Material: Brass, Stainless Steel

Finishes: US3, US4, US10, US10B, US26, US26D, US32, US32D

Fastener: 8 ea. #8 x 1 FH SMS, 8 ea. 8 x 3/4 FH Combo Screws, 4 ea. Plastic Anchors

- Features:**
- Patent #7,410,195.
 - Durable, tested over 1 million cycles.
 - Smaller profile adds stability to the door.
 - Only two 1 1/8" diameter holes for easier door preparation.
 - Preparation prevents the veneer from splitting at the corners of the door.
 - Quiet & smooth activation.
 - Fully automatic; opening active door retracts top & bottom bolts.
 - Non-handed.
 - Override feature prevents damage to doors or bolt if bolt head is blocked from entering strike.
 - Low (3 lbs. maximum) closing force. ADA Compliant.
 - Adjustable Bolt Head Rods: bolts can be vertically adjusted 1/2" for unusual clearances.
 - For up to 4'w x 9'h fire rated wood core & composite doors up to 1 1/2 hours fire rating.

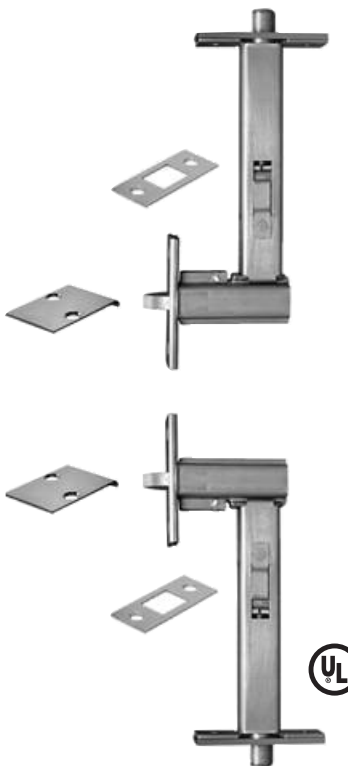

No.	Face Plate Size	Weight
1962	1 1/8" x 2 1/4"	1.7 lbs.

**Self Latching Flush Bolt With Bottom Fire Bolt
(for Fire Rated Metal Doors)
No. 1849**



Material: Brass, Stainless Steel

Finishes: US3, US4, US10, US10B, US26, US26D, US32D

Fastener: 8 ea. #8 x 3/4 FH Combo Screws, 4 ea. Plastic Anchors

- Features:**
- Non-handed.
 - Low (5 lbs. maximum) closing force.
 - Self latching top bolt.
 - Override feature prevents damage to doors or bolt if bolt head is blocked from entering strike.
 - Bolt head rod is adjustable up to 1 1/2".
 - For fire rated metal doors labeled A, B, C, D, & E up to 4'w x 10'h.
 - Thermal lock automatically locks the inactive door under high heat conditions due to fire.
 - Bottom fire bolt eliminates need for floor prep.
 - Oversize fire bolt strike hole allows for slight door misalignment.

No.	Size	Weight
1849	Top Bolt: 1" x 6 3/4" Bottom Bolt: 1 3/16" dia.	1.3 lbs.

**Self Latching Flush Bolt With Bottom Fire Bolt
(for Fire Rated Wood Doors)
No. 1949**



Material: Brass, Stainless Steel

Finishes: US3, US4, US10, US10B, US26, US26D, US32D

Fastener: 6 ea. #8 x 3/4 FH Combo Screws, 2 ea. Plastic Anchors;
3 ea. #10 x 1 FH WS

- Features:**
- Non-handed.
 - Low (5 lbs. maximum) closing force.
 - Self latching top bolt.
 - Override feature prevents damage to doors or bolt if bolt head is blocked from entering strike.
 - Bolt head rod is adjustable up to 1/2".
 - For fire rated UL listed 20-minute wood core and composite doors up to 4'w x 9'h.
 - Thermal lock automatically locks the inactive door under high heat conditions due to fire.
 - Bottom fire bolt eliminates need for floor prep.
 - Oversize fire bolt strike hole allows for slight door misalignment.

No.	Size	Weight
1949	Top Bolt: 1" x 8 1/2" Bottom Bolt: 1 3/16" dia.	1.6 lbs.

**Standard Head Pivot
No. CP10, CP10HD**

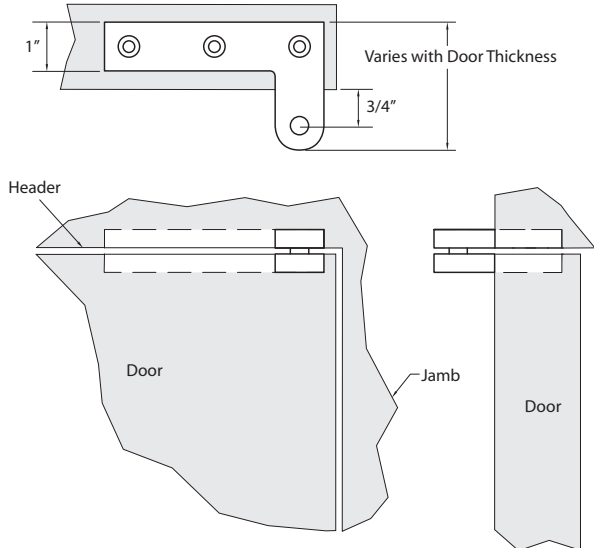

Material: Solid Brass

Finishes: US3, US4, US10, US10B, US26, US26D, other finishes available on request.

Fastener: 6 ea. #12 x 1 1/4" FH Wood Screws

Ordering: Specify door thickness.

- Features:**
- Mostly invisible when installed.
 - Includes Teflon® bearing for smooth silent operation.
 - Field changeable handing.
 - Standard Duty is made from 3/8" thick brass.
 - Heavy Duty (HD) is made from 1/2" thick brass and includes needle and thrust bearings.

No.	Material Size	Weight
CP10	3/8" thick for doors up to 200 lbs.	1.3 lbs.
CP10HD	1/2" thick for doors over 200 lbs.	1.9 lbs.

**Standard Head Pivot
No. CP20, CP20HD**

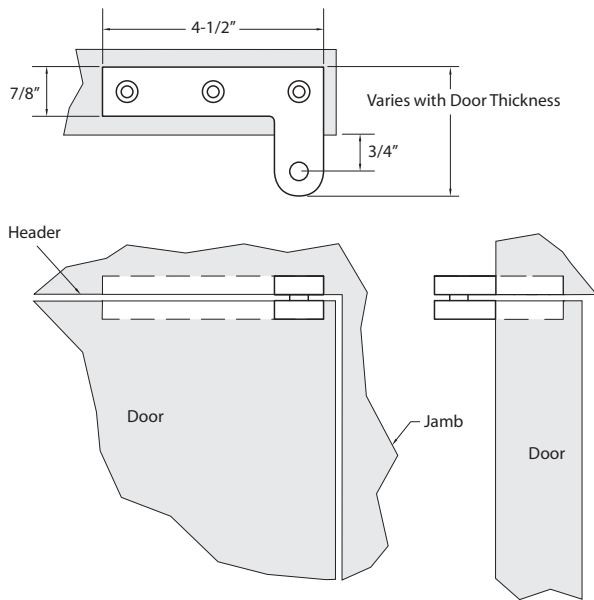

Material: Solid Brass

Finishes: US3, US4, US10, US10B, US26, US26D, other finishes available on request.

Fastener: 6 ea. #12 x 1 1/4" FH Wood Screws

Ordering: Specify door thickness if other than 1 3/4".

- Features:**
- Mostly invisible when installed.
 - Includes Teflon® bearing for smooth silent operation.
 - Field changeable handing.
 - Standard Duty is made from 3/8" thick brass.
 - Heavy Duty (HD) is made from 1/2" thick brass and includes needle and thrust bearings.

No.	Material Size	Weight
CP20	3/8" thick for doors up to 200 lbs.	1.2 lbs.
CP20HD	1/2" thick for doors over 200 lbs.	1.8 lbs.

Teflon® is a registered trademark of E. I. du Pont de Nemours and Company or its affiliates.

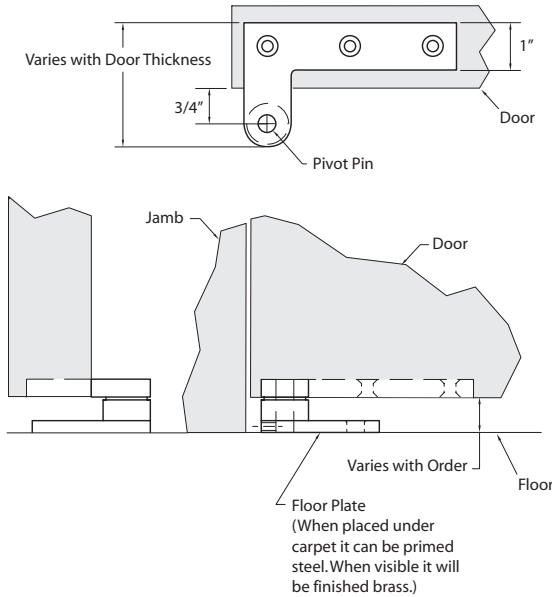

**Standard Floor Pivot
No. CP40, CP40HD**

Material: Solid Brass

Finishes: US3, US4, US10, US10B, US26, US26D, other finishes available on request.

Fastener: 6 ea. #12 x 1¼" FH Wood Screws

Ordering: Specify door thickness and floor clearing.

- Features:**
- Mostly invisible when installed.
 - Includes Teflon® bearing for smooth silent operation.
 - Field changeable handing.
 - Standard Duty is made from ⅜" thick brass.
 - Heavy Duty (HD) is made from ½" thick brass and includes needle and thrust bearings.

No.	Material Size	Weight
CP40	⅜" thick for doors up to 200 lbs.	1.3 lbs.
CP40HD	½" thick for doors over 200 lbs.	1.9 lbs.

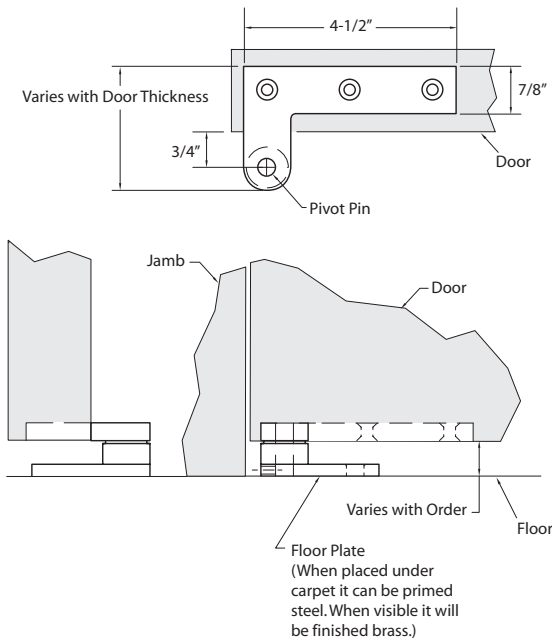

**Standard Floor Pivot
No. CP50, CP50HD**

Material: Solid Brass

Finishes: US3, US4, US10, US10B, US26, US26D, other finishes available on request.

Fastener: 6 ea. #12 x 1¼" FH Wood Screws

Ordering: Specify door thickness if other than 1¾".

- Features:**
- Mostly invisible when installed.
 - Includes Teflon® bearing for smooth silent operation.
 - Field changeable handing.
 - Standard Duty is made from ⅜" thick brass.
 - Heavy Duty (HD) is made from ½" thick brass and includes needle and thrust bearings.

No.	Material Size	Weight
CP50	⅜" thick for doors up to 200 lbs.	1.2 lbs.
CP50HD	½" thick for doors over 200 lbs.	1.8 lbs.

Teflon® is a registered trademark of E. I. du Pont de Nemours and Company or its affiliates.

ROCKWOOD

ASSA ABLOY

**F - Auxiliary Hardware
from Rockwood**



Auxiliary Hardware

Signage and Barrier Free Signage

Coat Hooks

Catches and Pocket Door Hardware

Knockers and Viewers

Filler Plates and Shims

ASSA ABLOY, the global leader
in door opening solutions

Door Knockers & Viewers



**Door Knocker
No. 611**

Material: Solid Cast Brass
Finishes: Available in standard architectural finishes (see page 7).
Fastener: 2 ea. 8-32 x 2 FH MS (for standard 1 3/4" doors); 2 ea. #8 Finish Washers
Options: • Drill for door viewer No. 621 (order viewer separately).
 • Engrave numbers or name. Assorted fonts are available.

No.	Size	Weight	ANSI A156.16
611	3 5/8" x 6 3/4"	0.6 lbs.	L03151



No. 614



No. 614V

**Door Knockers
No. 614, 614V**

Material: Cast Brass
Finishes: Available in standard architectural finishes (see page 7).
Fastener: 2 ea. 8-32 x 2 FH MS (for standard 1 3/4" doors); 2 ea. #8 Finish Washers
Features: No. 614V includes door viewer No. 622.
Options: Engrave numbers or name.

No.	Size	Weight	ANSI A156.16
614	2 1/8" x 3"	0.4 lbs.	L03161
614V	2 1/8" x 3"	0.4 lbs.	L03161



No. 619



No. 620/621



No. 624

**160° Door Viewers
No. 619, 620, 620VC, 621, 624**

Material: Brass
Finishes: Antique Bronze (ANT), Brass (BRS), Bright Chrome (CRM), Satin Nickel (STNN)
Other: Installation - drill 1/2" hole.
Features: No. 624 features a privacy cover to prevent visual intrusion from outside of the room.

No.	Inside Cover	For Doors	Weight	ANSI A156.16
619	No	1 1/16" to 1 1/4"	0.05 lbs.	L03222, L03172
620	No	1 3/8" to 2"	0.1 lbs.	L03222, L03172
620VC	Cover Only		0.1 lbs./10	
621	No	2" to 2 5/8"	0.1 lbs.	L03222, L03172
624	Yes	1 3/8" to 2"	0.1 lbs.	L03222, L03172

Recommended Location for Viewers

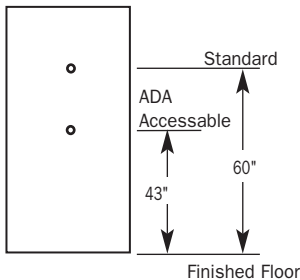

Viewers, Card Holders & Signs

**190° Door Viewer
 No. 622, 622VC, 626**



Material: Brass
Finishes: Antique Bronze (ANT), Brass (BRS), Bright Chrome (CRM), Dull Chrome (DCRM), Satin Nickel (STNN)
Other: Installation - drill $\frac{9}{16}$ " hole.
Features: No. 626 features a privacy cover to prevent visual intrusion from outside of the room.

No.	Inside Cover	For Doors	Weight	ANSI A156.16
622	No	1 $\frac{3}{8}$ " to 2 $\frac{1}{8}$ "	0.1 lbs.	L03221, L03172
622VC	Cover Only		0.1 lbs./10	
626	Yes	1 $\frac{3}{8}$ " to 2 $\frac{1}{8}$ "	0.1 lbs.	L03221, L03172

**Card Holder
 No. 651**



Material: Cast Brass
Finishes: Available in standard architectural finishes (see page 7).
Fastener: 2 ea. #8 x $\frac{3}{4}$ OH SMS

No.	Size	Card Size	Opening	Weight
651	2 $\frac{1}{2}$ " x 4 $\frac{1}{4}$ "	2" x 3 $\frac{1}{2}$ "	1 $\frac{3}{4}$ " x 3 $\frac{1}{4}$ "	0.2 lbs.

THIS DOOR TO REMAIN UNLOCKED DURING BUSINESS HOURS

**Decal
 No. 660**

Material: Silver Foil
Fastener: Self-adhesive mounting
Other: Black Lettering
Size: 1 $\frac{1}{2}$ " x 26 $\frac{1}{2}$ "

**Engraved Signs
No. 670 Series**



Material: .125" Plastic or .050" Aluminum, Brass, Bronze, Stainless Steel

Finishes: **Plastic Signs:** Available in black or brown with white lettering.

Metal Signs: Available in standard architectural finishes (see page 7).

Fastener: 2 ea. #6 x 5/8 OH SMS

Ordering: Specify product number, finish, and copy.

Features:

- Standard letter size is 1" high by 1/8" wide stroke. Other sizes from 1/2" to 3" are available.
- Standard font is US Block, other fonts available.
- Sign size is determined by the height and length of the engraving and is calculated to allow for an appropriate border.

Options:

- SA - self-adhesive mounting.
- Custom sizes and messages.

No.	Message	Size	ANSI 156.16
670	specify copy	2" x width required	L03201
670M	Men	2" x 5"	L03201
670W	Women	2" x 7"	L03201
670R	Restroom	2" x 10"	L03201



No. 674L



No. 674H

**Engraved Signs
No. 674H, 674L**

Material: .125" Plastic or .050" Aluminum, Brass

Finishes: **Plastic Signs:** Available in black or brown with white lettering.

Metal Signs: Available in standard architectural finishes (see page 7).

Fastener: Self-adhesive mounting

Size: 1" x 4 1/2"

. MEN .

. WOMEN .

. RESTROOM .

. ADMINISTRATION .

**Barrier Free Engraved Signs
 (with Braille Translation)
 No. BF680 Series**

- Material:** .125" Non-Glare Plastic or .050" Brass, Bronze
- Finishes:** **Plastic Signs:** Available in black, blue, brown, or red with white lettering.
Metal Signs: Available in standard architectural finishes (see page 7).
- Fastener:** 2 ea. #6 x 5/8 OH SMS
- Ordering:** Specify product number, finish, and copy.
- Options:**
- SA - self-adhesive mounting.
 - Custom sizes and messages.
- Features:**
- Plastic signs meet ANSI A117.1-1998 section 703 requirements.
 - 1" letter height is standard; other sizes available from 5/8" to 2".
 - Meets width to height ratio requirements.
 - Sign size is determined by the height and length of the engraving and is calculated to allow for an appropriate border.
 - Grade 2 braille translation on sign.
 - Screws provided for secure mounting.
 - Made to order, any copy available.
 - Plastic signs have easy to read letters and numbers that are raised 1/32" from sign surface.
 - Plastic signs characters and background have a non-glare finish of contrasting light on dark color.
 - Metal signs have easy to read raised black lettering.

No.	Message	Size	ANSI 156.16
BF680	specify copy	2½" x width required	L03201
BF680M	Men	2½" x 5"	L03201
BF680W	Women	2½" x 7"	L03201
BF680R	Restroom	2½" x 9"	L03201

BF Series ADA Signs

Material: .125" Non-Glare Plastic or .050" Brass, Bronze

Finishes: **Plastic Signs:** Available in black, blue, brown, or red with standard 1" white lettering.
Metal Signs: Available in standard architectural finishes (see page 7).

Fastener: 4 ea. #6 x 5/8 OH SMS

Size: 8" x 8"

Ordering: Specify background finish along with any options.

Options: • SA - self-adhesive mounting.

Features: Plastic Signs

- Raised characters and Grade 2 Braille translation.
- Meets ADAAG Section 4.30 requirements.

Metal Signs

- Raised black lettering.
- Grade 2 Braille translation.
- Attractive architectural finishes.



Recommended Mounting Location for Signs

EXCERPTS FROM ADA ACCESSIBILITY GUIDELINES FOR BUILDINGS AND FACILITIES (ADAAG).

4.30.6 Mounting Location and Height: Where permanent identification is provided for rooms and spaces, signs shall be installed on the wall adjacent to the latch side of the door. Where there is no wall space to the latch side of the door, including at double leaf doors, signs shall be placed on the nearest adjacent wall. Mounting height shall be 60 inches (1525 mm) above the finish floor to the centerline of the sign. Mounting location for such signage shall be so that a person may approach within 3 inches (76 mm) of signage without encountering protruding objects or standing within the swing of a door.

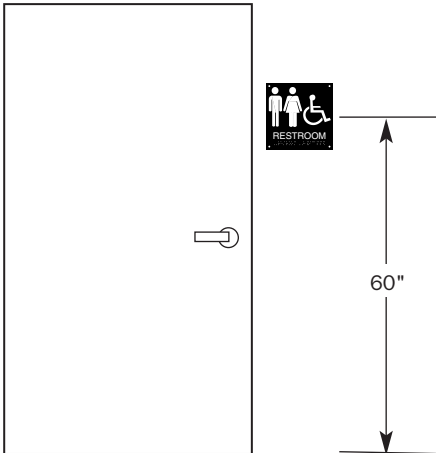

Tactile Signage - with Braille

BFM Series ADA Molded Plastic Signs

- Material:** Molded Plastic
- Colors:** 5/8" White Lettering on choice of blue or black background.
- Fastener:** Self-adhesive mounting.
- Size:** 6" x 9"
- Ordering:** Specify product number and background color.
- Features:**
- Raised lettering and Grade 2 Braille translation.
 - Meets ADAAG Section 4.30 requirements.
 - Economical molded plastic.

No. BFM682



No. BFM684



No. BFM685



No. BFM686



No. BFM687



No. BFM688



No. BFM689



Recommended Mounting Location for Signs

EXCERPTS FROM ADA ACCESSIBILITY GUIDELINES FOR BUILDINGS AND FACILITIES (ADAAG).

4.30.6 Mounting Location and Height: Where permanent identification is provided for rooms and spaces, signs shall be installed on the wall adjacent to the latch side of the door. Where there is no wall space to the latch side of the door, including at double leaf doors, signs shall be placed on the nearest adjacent wall. Mounting height shall be 60 inches (1525 mm) above the finish floor to the centerline of the sign. Mounting location for such signage shall be so that a person may approach within 3 inches (76 mm) of signage without encountering protruding objects or standing within the swing of a door.

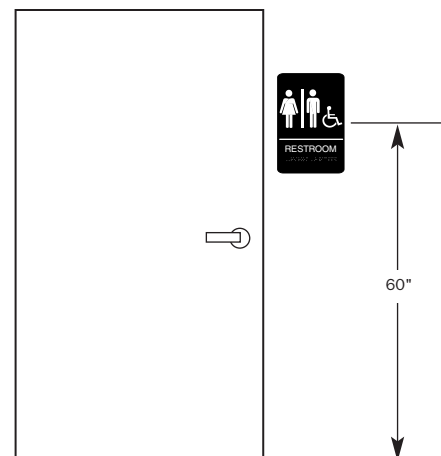

**Hand Rail Brackets
No. 700, 701, 702**



Material: Cast Brass

Finishes: Available in standard architectural finishes (see page 7).

Fastener: Wood Rail

Metal Rail

700	5/16-18 x 1 1/2 FH MS, Lead Anchor; 3 ea. 12-24 x 1 FH MS; 2 ea. #8 x 3/4 OH SMS; 1 ea. Back Plate	5/16-18 x 1 1/2 FH MS, Lead Anchor; 3 ea. 12-24 x 1 FH MS; 2 ea. 8-32 x 3/4 OH MS; 1 ea. Back Plate
701	5/16-18 x 3 FH MS, Toggle; 3 ea. 12-24 x 1 FH MS; 2 ea. #8 x 3/4 OH SMS; 1 ea. Back Plate	5/16-18 x 3 FH MS, Toggle; 3 ea. 12-24 x 1 FH MS; 2 ea. 8-32 x 3/4 OH MS; 1 ea. Back Plate
702	3 ea. #12 x 2 FH WS; 2 ea. #8 x 3/4 OH SMS	3 ea. #12 x 2 FH WS; 2 ea. 8-32 x 3/4 OH MS

Ordering: Specify Wood Rail or Metal Rail.

No.	Base	Projection (to Rail Centerline)	Weight
700	2 13/16"	3 1/2"	2.0 lbs.
701	2 13/16"	3 1/2"	1.8 lbs.
702	2 13/16"	3 1/2"	1.5 lbs.

**Small Coat Hook
 No. 790**



Material: Cast Brass
Finishes: Available in standard architectural finishes (see page 7).
Fastener: 2 ea. #6 x $\frac{5}{8}$ OH SMS

No.	Size	Projection	Weight	ANSI A156.16
790	1 $\frac{1}{4}$ "w x 1 $\frac{3}{8}$ "h	1 $\frac{1}{8}$ "	1.5 lbs./10	L03111

**Small Double Coat Hook
 No. 796**



Material: Cast Brass
Finishes: Available in standard architectural finishes (see page 7).
Fastener: 2 ea. #6 x $\frac{3}{4}$ OH SMS

No.	Size	Projection	Weight
796	1 $\frac{1}{8}$ "w x 1 $\frac{1}{8}$ "h	1 $\frac{1}{8}$ "	1.5 lbs./10

**Medium Coat Hook
 No. 802**



Material: Cast Brass
Finishes: Available in standard architectural finishes (see page 7).
Fastener: 2 ea. #6 x $\frac{3}{4}$ RH WS

No.	Size	Projection	Weight	ANSI A156.16
802	1 $\frac{3}{16}$ "w x 1 $\frac{1}{2}$ "h	3"	1.7 lbs./10	L03111

**Medium Coat Hook
 No. 806**



Material: Cast Brass
Finishes: Available in standard architectural finishes (see page 7).
Fastener: 2 ea. #6 x $\frac{3}{4}$ OH WS

No.	Size	Projection	Weight	ANSI A156.16
806	1 $\frac{1}{16}$ "w x 1 $\frac{1}{4}$ "h	3 $\frac{3}{8}$ "	1.9 lbs./10	L03111

**1¼" Ball Knob
 No. 841**



Material: Solid Brass
Finishes: US3, US26; other finishes available upon request.
Fastener: 8-32 x 1 TH MS
Options: Other screw lengths available upon request.

No.	Base	Projection	Weight	ANSI A156.9
841	¾" dia.	1⅞"	2.5 lbs./10	B02131

**Utility Pull
 No. 845**



Material: Aluminum, Brass
Finishes: US3, US4, US10, US10B, US26, US26D, Burnished Aluminum (ALM)
Fastener: 4 ea. #8 x ¾ OH SMS

No.	Size	Projection	Weight
845	1⅞" x 5⅞"	1½"	2.5 lbs./10

**Solid Wire Pull
 No. 850, 851, 852, 853**



Material: Brass, Bronze, Stainless Steel
Finishes: US3, US4, US10, US10B, US26, US26D, US32D, US32DMS
Fastener: 8-32 x 1 TH MS
Options: Other CTC's available upon request.

No.	Size	CTC	Projection	Weight	ANSI A156.9
850	⅝" dia.	2¾"	1¼"	3.4 lbs./25	B02011
851	⅝" dia.	3"	1¼"	3.8 lbs./25	B02011
852	⅝" dia.	3½"	1¼"	3.9 lbs./25	B02011
853	⅝" dia.	4"	1¼"	4.0 lbs./25	B02011

**Heavy Wire Pull
 No. 856**



Material: Brass, Bronze, Stainless Steel
Finishes: US3, US4, US10, US10B, US26, US26D, US32D, US32DMS
Fastener: 8-32 x 1 TH MS
Options: Other CTC's available upon request.

No.	Size	CTC	Projection	Weight	ANSI A156.9
856	½" dia.	4"	1¾"	4.5 lbs./10	B02011



**Flush Cup Pull
 No. 860**

Material: Brass, Stainless Steel
Finishes: US3, US10B, US32D
Fastener: 2 ea. #4 x 5/8 OH WS
Other: See website for installation template.

No.	Size	Weight	ANSI A156.14
860	2½" dia.	0.9 lbs./10	B02201



**Wrought Flush Pull
 No. 870**

Material: Brass, Stainless Steel
Finishes: US3, US10B, US32D
Fastener: 2 ea. #4 x 5/8 OH WS

No.	Size	Weight	ANSI A156.14
870	1⅜" x 3⅜"	0.5 lbs./10	D0781



**Cast Flush Pull
 No. 872**

Material: Cast Brass
Finishes: US3, US10B, US26D; other finishes available upon request.
Fastener: 2 ea. #4 x 5/8 OH WS

No.	Size	Weight	ANSI A156.14
872	1⅝" x 3⅜"	0.2 lbs.	D0781



**Cast Lever Edge Pull
No. 880**

Material: Cast Brass
Finishes: US3, US10B, US26D; other finishes available upon request.
Fastener: 2 ea. #6 x 3/4 FH SMS

No.	Size	Weight	ANSI A156.14
880	3/4" x 3 7/8"	0.2 lbs.	D2801



**Concealed Edge Pull
No. 885**

Material: Brass
Finishes: Available in standard architectural finishes (see page 7).
Fastener: 2 ea. #6 x 1 FH WS

No.	Size	Weight
885	1" x 4 1/4"	0.5 lbs.



**Pocket Door Pull
No. 890**

Material: Brass
Finishes: US3, US10B, US26, US26D
Fastener: 2 ea. #6 x 5/8 OH SMS
Other: For use on 1 3/8" and 1 3/4" doors.

No.	Size	Weight	ANSI A156.14
890	2 1/2"w x 2 3/4"h	0.4 lbs.	D0821



**Pocket Door Privacy Latch
No. 891**

Material: Brass
Finishes: US3, US10B, US26, US26D
Fastener: 4 ea. #6 x 5/8 OH SMS
Other: For use on 1 3/8" and 1 3/4" doors.
Features:

- Turn piece locks to jamb strike.
- Emergency release on opposite side.

No.	Size	Weight	ANSI A156.14
891	2 1/2"w x 2 3/4"h	0.4 lbs.	D0831

**Heavy Duty Magnetic Catch
 No. 900**



Material: Aluminum

Finishes: Brass (BRS), Natural Aluminum (ALM)

Fastener: Body: 2 ea. #6 x 1¼ TH SMS

Strike: 2 ea. #6 x ½ FH SMS

- Features:**
- Includes installation instructions.
 - Dual double-pole, self-aligning magnets.
 - Packed with two short strikes and one long strike.
 - Can be used on pair of doors or single door.

No.	Body Size	Strike Size	Weight	ANSI A156.9
900	9/16" x 3 1/8" x 1"	1 ea. 5/8" x 3 1/8" 2 ea. 5/8" x 1 1/8"	0.3 lbs.	B03161

**Extra Heavy Duty Magnetic Catch
 No. 901**



Material: Aluminum

Finishes: Brass (BRS), Natural Aluminum (ALM)

Fastener: Body: 2 ea. #6 x 1½ TH SMS

Strike: 2 ea. #6 x ½ FH SMS

- Features:**
- Includes installation instructions.
 - Dual triple-pole, self-aligning magnets.
 - Packed with two short strikes and one long strike.
 - Can be used on pair of doors or single door.

No.	Body Size	Strike Size	Weight	ANSI A156.9
901	13/16" x 3 1/3" x 1"	1 ea. 7/8" x 3 1/8" 2 ea. 7/8" x 1 1/8"	0.3 lbs.	B03161

**Adjustable Ball Catch - Square Corners
No. 910, 911**



No. 910

- Material:** Brass
Finishes: US3, US26D
Fastener: 4 ea. #6 x 3/4 FH SMS
Other: No. 910: Narrow strike for mounting on door, catch in jamb.
No. 911: Wide strike for mounting on jamb, catch in door.
Features: Dual adjustment for door clearance and holding strength.

No.	Body Size	Strike Size	Weight	ANSI A156.9
910	1" x 2 1/8"	1 1/16"W x 2 1/8"	0.2 lbs.	B03017
911	1" x 2 1/8"	1 3/8"W x 2 1/8"	0.2 lbs.	B03017

**Adjustable Ball Catch - Round Corners
No. 910RC, 911RC**



No. 911RC

- Material:** Brass
Finishes: US3, US26D
Fastener: 4 ea. #6 x 3/4 FH SMS
Other: No. 910RC: Narrow strike for mounting on door, catch in jamb.
No. 911RC: Wide strike for mounting on jamb, catch in door.
Features:
 - 1/4" radius corners for easy mortise installation.
 - Dual adjustment for door clearance and holding strength.

No.	Body Size	Strike Size	Weight	ANSI A156.9
910RC	1" x 2 1/8"	1 1/16"W x 2 1/8"	0.2 lbs.	B03017
911RC	1" x 2 1/8"	1 3/8"W x 2 1/8"	0.2 lbs.	B03017

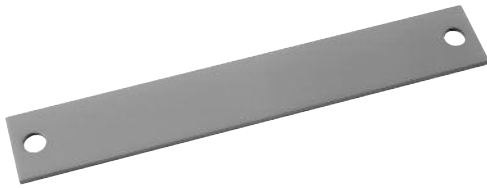

**Door Edge Filler Plate
No. DF86**

Material: Steel
Finishes: Prime Coat
Fastener: 2 ea. 12-24 x 1/2 FH MS
Other: For Gov. 86 mortise lock face.

No.	Size	Weight	Pack Quantity
DF86	1 1/4" x 8" x 3/16"	11.9 lbs./25	25



**Frame Hinge Filler Plate
No. DFF4**

Material: Steel
Finishes: Prime Coat
Fastener: 2 ea. 12-24 x 1/2 FH MS
Other: For 1 3/4" rabbet frames.

No.	Size	Weight	Pack Quantity
DFF4	1 5/8" x 4 1/2"	6.8 lbs./25	25

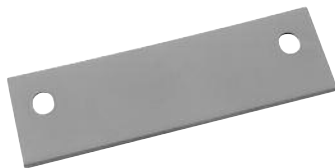

**Frame Hinge Filler Plate
No. DFF5**

Material: Steel
Finishes: Prime Coat
Fastener: 2 ea. 12-24 x 1/2 FH MS
Other: For 1 3/4" rabbet frames.

No.	Size	Weight	Pack Quantity
DFF5	1 5/8" x 5"	7.9 lbs./25	25

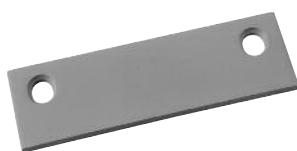

**Beveled Door Hinge Filler Plate
No. DHF4B**

Material: Steel
Finishes: Prime Coat
Fastener: 2 ea. 12-24 x 1/2 FH MS
Other: For handed doors (beveled).

No.	Size	Weight	Pack Quantity
DHF4B	1 1/2" x 4 1/2"	6.4 lbs./25	25

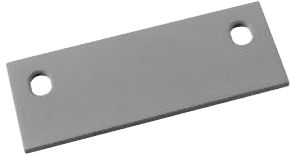

**Square Door Hinge Filler Plate
No. DHF4S**

Material: Steel
Finishes: Prime Coat
Fastener: 2 ea. 12-24 x 1/2 FH MS
Other: For non-handed doors (square edge).

No.	Size	Weight	Pack Quantity
DHF4S	1 3/4" x 4 1/2"	7.7 lbs./25	25



**Beveled Door Hinge Filler Plate
No. DHF5B**

Material: Steel
Finishes: Prime Coat
Fastener: 2 ea. 12-24 x 1/2 FH MS
Other: For handed doors (beveled).

No.	Size	Weight	Pack Quantity
DHF5B	1 1/2" x 5"	7.2 lbs./25	25

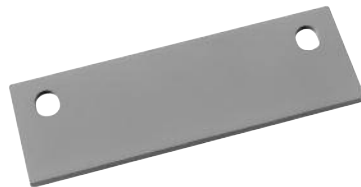

**Square Door Hinge Filler Plate
No. DHF5S**

Material: Steel
Finishes: Prime Coat
Fastener: 2 ea. 12-24 x 1/2 FH MS
Other: For non-handed doors (square edge).

No.	Size	Weight	Pack Quantity
DHF5S	1 3/4" x 5"	8.5 lbs./25	25

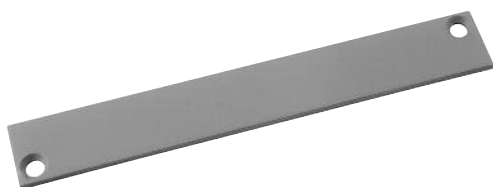

**Flush Bolt Filler Plate
No. FBF48**

Material: Steel
Finishes: Prime Coat
Fastener: 2 ea. 8-32 x 1/2 FH MS

No.	Size	Weight	Pack Quantity
FBF48	1" x 6 3/4"	6.4 lbs./25	25



**Flush Bolt Strike Filler Plate
No. FBS48**

Material: Steel
Finishes: Prime Coat
Fastener: 2 ea. 8-32 x 1/2 FH MS

No.	Size	Weight	Pack Quantity
FBS48	15/16" x 2 1/4"	1.3 lbs./25	25



**Door Face Filler Plate
No. FC161**

Material: Steel
Finishes: Prime Coat
Fastener: Sex Bolt and Sleeve
Other: To cover up to 2 1/8" lock hole.

No.	Size	Weight	Pack Quantity
FC161	2 5/8" dia.	4.0 lbs./25	25



**Door Face Filler Plate
No. FD160**

Material: Steel
Finishes: Prime Coat
Fastener: Sex Bolt and Sleeve
Other: To cover up to 1 1/2" lock hole.

No.	Size	Weight	Pack Quantity
FD160	1 3/4" dia.	2.0 lbs./25	25

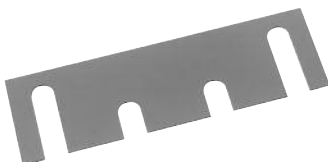

**4 1/2" Hinge Shim - .028" Thick
No. HS42**

Material: Steel
Finishes: Galvanized Coat

No.	Size	Weight	Pack Quantity
HS42	1 7/16" x 4 1/2"	2.2 lbs./50	50



**4½" Hinge Shim - .065" Thick
No. HS44**

Material: Steel
Finishes: Galvanized Coat

No.	Size	Weight	Pack Quantity
HS44	1 7/16" x 4 1/2"	4.4 lbs./50	50

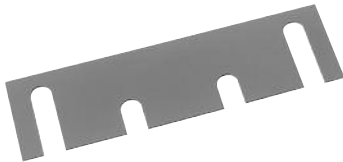

**5" Hinge Shim - .028" Thick
No. HS52**

Material: Steel
Finishes: Galvanized Coat

No.	Size	Weight	Pack Quantity
HS52	1 7/16" x 5"	2.3 lbs./50	50



**5" Hinge Shim - .065" Thick
No. HS54**

Material: Steel
Finishes: Galvanized Coat

No.	Size	Weight	Pack Quantity
HS54	1 7/16" x 5"	4.5 lbs./50	50



**Latch Adapter Plate
No. LA86**

Material: Steel
Finishes: Prime Coat
Fastener: 2 ea. 12-24 x 1/2 FH MS
Other: Change 86 cutout to 161 template.

No.	Size	Weight	Pack Quantity
LA86	1 1/4" x 8"	7.5 lbs./25	25



**Door Edge Filler Plate
 No. LF161**

Material: Steel
Finishes: Prime Coat
Fastener: 2 ea. 8-32 x 1/2 FH MS
Other: For Gov. 161 Latch.

No.	Size	Weight	Pack Quantity
LF161	1 1/8" x 2 1/4"	2.5 lbs./25	25



**Strike Filler Plate
 No. SF160**

Material: Steel
Finishes: Prime Coat
Fastener: 2 ea. 8-32 x 1/2 FH MS
Other: For Gov. 160.

No.	Size	Weight	Pack Quantity
SF160	1 1/8" x 2 3/4"	2.1 lbs./25	25



**Strike Filler Plate
 No. SFASA**

Material: Steel
Finishes: Prime Coat
Fastener: 2 ea. 12-24 x 1/2 FH MS
Other: For A.S.A. strike.

No.	Size	Weight	Pack Quantity
SFASA	1 1/4" x 4 7/8"	4.9 lbs./25	25



**Strike Filler Plate
 No. SFB160**

Material: Steel
Finishes: Prime Coat
Fastener: 2 ea. 8-32 x 1/2 FH MS
Other: For Schlage "B" lock and other dead lock strikes.

No.	Size	Weight	Pack Quantity
SFB160	1 1/8" x 2 3/4"	1.9 lbs./25	25

ROCKWOOD



ASSA ABLOY

Copyright © 2010, Rockwood Manufacturing Company, an ASSA ABLOY Group company. All rights reserved.
Reproduction in whole or in part without the express written permission of Rockwood Manufacturing Company is prohibited.

All contents current at time of publication. Rockwood Manufacturing Company reserves the right to change the availability of any item in this binder, its design, construction, and/or its materials.

Rockwood Manufacturing Company • P.O. Box 79 • Rockwood, PA 15557
Phone: 800-458-2424 • Fax: 800-922-9212 • Website: www.rockwoodmfg.com

ASSA ABLOY is the global leader in door opening solutions, dedicated to satisfying end-user needs for security, safety and convenience.