



1100 Series

Industrial Door Closers



introduction



The Yale® 1100 series industrial door closers are ideal for a wide variety of commercial applications where ease of use and installation are required at an economic price.

The 1100 series features rugged construction, adjustments for closing and latch speed, and rack and pinion operation.

features

- 1101BF (non-hold open) and 1111BF (hold open) door closers are adjustable spring sizes 1 through 4
- 1104BC (non-hold open) door closers are spring size 4
- Non-handed
- Full rack and pinion
- Aluminum
- Tri-packed: regular, parallel or top jamb mounting
- Adjustable backcheck valve
- Adjustable closing speed valve
- Adjustable latching speed valve
- Auxiliary door stop required
- Sleeve nuts included with all models (1-3/4")
- 5-year limited warranty
- 1101BF closers available with or without cover

certifications

- UL and cUL listed. This includes compliance to UL10C. 
- 1101BF/1111BF - designed to meet requirements for ANSI/BHMA A156.4 Grade 1. Door closers meet handicapped requirements for light to medium weight interior doors. 
- 1104BC - designed to meet requirements for ANSI/BHMA A156.4 Grade 2

door closing latching cycle

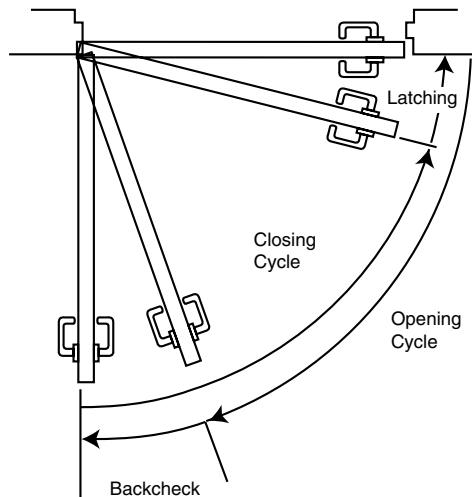

contents

- Introduction 2
- Features 2
- Certifications 2
- Door Closing Latching Cycle 2
- Applications 3
- Dimensions 3
- How To Order 3
- Finishes 3

applications

regular arm

top jamb

parallel arm



dimensions

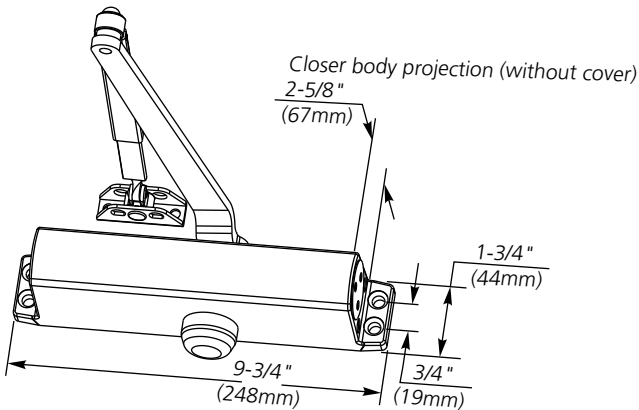

how to order

Model#	Description	Finish
1101BF	Multi-sized Closer - Non-Hold Open	689 or 690
1101BFxCOV	Multi-sized Closer - Non-Hold Open with Cover	
1104BC	Size 4 Closer with Backcheck - Non-Hold Open	
1111BF	Multi-sized Closer - Hold Open	

Sleeve Nuts furnished standard with all models.

Note: Contact factory if door weight exceeds 250 lbs.

parts list

Description	Part Number*
Sleeve Nuts (1-3/4" door only)	SN-134
Cover (order by part number)	1100COV

* - specify finish when ordering

finishes

ANSI/BHMA Code	Finish Description
689	Aluminum Painted
690	Dark Bronze Painted